

SBC8155

**Pentium All-in-One
PCI/ISA
CPU Card Series**

User's Manual

Disclaimers

The information in this manual has been carefully checked and is believed to be accurate. AXIOM Technology Co., Ltd. assumes no responsibility for any infringements of patents or other rights of third parties which may result from its use.

AXIOM Technology assumes no responsibility for any inaccuracies that may be contained in this document. AXIOM Technology makes no commitment to update or to keep current the information contained in this manual.

AXIOM Technology reserves the right to make improvements to this document and/or product at any time and without notice.

No part of this document may be reproduced, stored in a retrieval system, or transmitted, in any form or by any means, electronic, mechanical, photocopying, recording, or otherwise, without the prior written permission of AXIOM Technology Co., Ltd.

**©Copyright 2000 by AXIOM Technology Co., Ltd.
All rights reserved.
November 2000, Version B4
Printed in Taiwan**

ESD Precautions

Integrated circuits on computer boards are sensitive to static electricity. To avoid damaging chips from electrostatic discharge, observe the following precautions:

- Do not remove boards or integrated circuits from their anti-static packaging until you are ready to install them.
- Before handling a board or integrated circuit, touch an unpainted portion of the system unit chassis for a few seconds. This helps to discharge any static electricity on your body.
- Wear a wrist-grounding strap, available from most electronic component stores, when handling boards and components.

Trademarks Acknowledgments

AXIOM is a trademark of AXIOM Technology Co., Ltd.

IBM is a registered trademark of International Business Machines Corporation.

MS-DOS, Windows '95, Windows NT are trademarks of Microsoft Corporation.

AWARD is a trademark of Award Software, Inc.

Cyrix is a trademark of Cyrix Corporation.

IBM, PC/AT, PS/2, VGA are trademarks of International Business Machines Corporation.

Intel and Pentium are trademarks of Intel Corporation.

Adaptec AIC7880 is a trademark of Adaptec, Inc.

Realtek RTL-8139 is a registered trademark of Realtek Semiconductor Corporation.

Winbond W83977 is a trademark of Winbond Electronics Corp.

Other brand names and trademarks are the properties and registered brands of their respective owners.

This page does not contain any information.

Table of Contents

CHAPTER 1 INTRODUCTION	
1.1	GENERAL DESCRIPTION 1
1.2	SPECIAL FEATURES 2
1.2.1	Infrared Data Association..... 2
1.2.2	Universal Serial Bus..... 2
1.2.3	Ultra DMA/33 2
1.3	SPECIFICATIONS 3
CHAPTER 2 JUMPERS AND CONNECTORS	
2.1	BOARD LAYOUT 5
2.2	JUMPER SETTINGS 6
2.2.1	CPU Settings..... 7
2.2.1.1	CPU Bus Clock Selection: JP5..... 7
2.2.1.2	CPU Clock Ration Selection: JP1..... 7
2.2.1.3	CPU V _{io} (V _{cc3}) Selection: JP2, JP4 7
2.2.1.4	CPU V _{core} Selection: JP3 8
2.2.1.5	CPU Settings Reference..... 9
2.2.2	Power Supply Selection: JP6, JP7, JP16..... 11
2.2.3	DiskOnChip® Memory Segment: JP9 11
2.2.4	Watchdog Function: JP8..... 11
2.2.5	RS232/422/485 (COM2) Selection: JP10, JP11, JP12, JP17 11
2.3	CONNECTORS 12
2.3.1	SBC8155VES Connectors..... 12
2.3.2	SBC8155V Connectors..... 12
2.3.3	SBC8155 Connectors..... 13
2.3.4	SBC8155VE Connectors 13
2.3.5	Improvised Connectors..... 13
2.3.5.1	ATX Power Switch/Soft Power Switch/SMI Switch13
2.3.5.2	General Output Connector14
CHAPTER 3 INSTALLATION	
3.1	SYSTEM MEMORY 17
3.1.1	System Memory Installation 17
3.2	CPU INSTALLATION 18
3.3	CONFIGURING POWER SUPPLY 18
3.3.1	ATX Power Supply 18
3.3.2	AT Power Supply 18
3.4	COMPLETING INSTALLATION 19

CHAPTER 4 HARDWARE DESCRIPTION	
4.1	CPU 21
4.2	BIOS 21
4.3	I/O PORT ADDRESS MAP 21
4.4	INTERRUPT CONTROLLER 23
4.5	IDE INTERFACE CONNECTOR 23
4.6	VGA INTERFACE CONNECTOR 24
4.7	FLOPPY DISK CONTROLLER 24
4.8	PARALLEL PORT INTERFACE 24
4.9	SERIAL PORT INTERFACE 25
4.9.1	Serial Ports IRQ Selection 25
4.10	KEYBOARD AND PS/2 MOUSE CONNECTORS 25
4.11	USB CONNECTOR 25
4.12	ETHERNET CONNECTOR 26
4.13	SCSI CONNECTORS 26
4.14	IRDA CONNECTOR 26
4.15	EXTERNAL/INTERNAL BATTERY SELECT 27
4.16	CPU FAN CONNECTOR 27
CHAPTER 5 DISPLAY DRIVERS	
5.1	GENERAL DESCRIPTION 29
5.2	FEATURES 29
5.3	DRIVERS SUPPORTED 29
CHAPTER 6 ETHERNET	
6.1	GENERAL DESCRIPTION 31
6.2	FEATURES 31
6.3	DRIVERS SUPPORTED 31
CHAPTER 7 AWARD BIOS UTILITY	
7.1	ENTERING SETUP 33
7.2	CONTROL KEYS 34
7.3	GETTING HELP 34
7.4	THE MAIN MENU 35
7.5	STANDARD CMOS SETUP MENU 37
7.6	BIOS FEATURES SETUP MENU 40
7.7	CHIPSET FEATURES SETUP MENU 46
7.8	POWER MANAGEMENT SETUP 49
7.9	PNP/PCI CONFIGURATION SETUP 54
7.10	INTEGRATED PERIPHERALS 57
7.11	SUPERVISOR/USER PASSWORD SETTING 60
7.12	IDE HDD AUTO DETECTION 62
7.13	HARD DISK LOW LEVEL FORMAT UTILITY 65
7.14	POWER-ON BOOT 66

APPENDIX A	WATCHDOG TIMER	
	USING THE WATCHDOG FUNCTION	67
APPENDIX B	CONNECTOR PIN	
	ASSIGNMENTS	
	40-pin IDE Interface Connector: CN4 and CN5	69
	CRT/VGA Connector: CN13	69
	Floppy Disk Connector: CN6	70
	Parallel Port Connector: CN7	70
	RS-232 pin assignments for COM1 (CN12)	71
	RS-232/422/485 pin assignments for COM1 & COM2 (CN8, CN9)	71
	External Keyboard Connector: CN15	71
	PS/2 Mouse Connector: CN16	72
	USB Connector: CN10	72
	Ethernet Connector: CN11 (SBC8155VES & SBC8155VE only)	72
	General Output Connector: CN1	73
	IrDA Connector: CN17	73
	2-pin CPU Fan Connector: CN20	74
	PICMG Slot Connector	74
APPENDIX C	AWARD BIOS REFERENCE	
	POST MESSAGES	79
	POST BEEP	79
	ERROR MESSAGES	79
	POST CODES	84

This page does not contain any information.

Chapter 1

Introduction

1.1 General Description

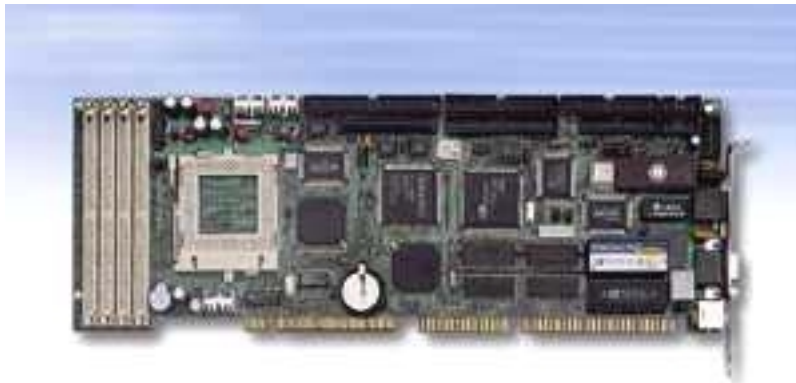

The **SBC8155** CPU card consists of industrial grade CPU cards incorporating the Intel 430TX PCI chipset and the Winbond 83977 I/O chipset, both ensuring its compatibility with ISA bus passive backplanes. Its 6-layer structure reduces signal noise and meets all green functions with its built-in power management feature. These advanced concepts along with the PCI Local Bus architecture brings outstanding performance to Windows-based applications.

Designed for the professional embedded developers, the Pentium all-in-one **SBC8155** CPU card is virtually your ultimate one-step solution to various applications.

1.2 Special Features

1.2.1 Infrared Data Association

IrDA is a standard developed for transmitting data via infrared light waves. Increasingly, computers and other devices come with IrDA ports. This enables you to transfer data from one device to another without any cables.

Connector provisions on the **SBC8155** supports this optional wireless transmitting and receiving infrared module. This module mounts to a small opening on system cases that supports this feature. Please refer to Chapter 2 and the Appendix for the IrDA connector and its respective pin assignments.

1.2.2 Universal Serial Bus

USB is a new external bus standard that supports data transfer rates of 12 Mbps (12 million bits per second). A single USB port can be used to connect up to 127 peripheral devices, such as mice, modems, and keyboards. USB also supports Plug-and-Play installation and hot plugging.

USB has recently become more widespread. It is expected to eventually completely replace serial and parallel ports. Onboard the **SBC8155** CPU card sits two USB ports available for USB device(s) connection. Chapter 2 and the Appendix on this manual list the designated USB connector(s) and their respective pin assignments.

1.2.3 Ultra DMA/33

The duo combination of the **SBC8155** architecture along with the Intel 430TX PCset greatly enhances IDE transfer rate with the deployment of Bus Master Ultra DMA/33. Improving IDE data transfer rate up to 33MB/sec, Ultra DMA/33 too delivers flexibility and convenience to existing ATA-2 IDE specifications. This compatibility feature of Ultra DMA/33 eliminates the upgrade considerations of current hard drives and cables.

1.3 Specifications

- **CPU:** Intel Pentium P54C/P55C/MMX, Cyrix 6x86/6x86L/6x86(MX), AMD K5/K6 90-300 MHz, K6-2/K6-III 333-400 MHz
- **Chipset:**
 - **System chipset:** Intel 82430TX PCI chipset
 - **I/O chipset:** Winbond W83977
- **BIOS:** Award PnP Flash BIOS
- **System Memory:** 4 x 72-pin SIMM socket supporting up to 256MB; EDO/FPM memory compatible
- **L2 Cache:** Onboard 512KB
- **Watchdog Timer:** Generates a system reset
16-level software programmable time and temperature interval from 0.5 to 1000 seconds
- **Ethernet:** Onboard Realtek 8139 chip with boot ROM function, 10/100 Base-T Interface via RJ-45 connector
- **VGA Controller:**
 - Cirrus Logic GD5446 CRT VGA PCI local-bus controller with 2MB display DRAM
 - Supports up to 1280 x 1024 resolution
- **SCSI Interface:**
 - Supports one 8-bit Ultra SCSI port single-ended or differential
 - One 16-bit fast and Ultra Wide SCSI port, single-ended or differential
 - Connects up to 15 SCSI peripherals with Ultra Wide SCSI feature
 - 20MB/sec synchronous Ultra SCSI data rate
 - 40MB/sec Ultra Wide SCSI data rate
- **DiskOnChip®:**
 - Onboard socket for flash memory disk support
- **Dimensions:** 338 (L) x 122 (W) mm

This page does not contain any information.

Chapter 2 Jumpers and Connectors

2.1 Board Layout

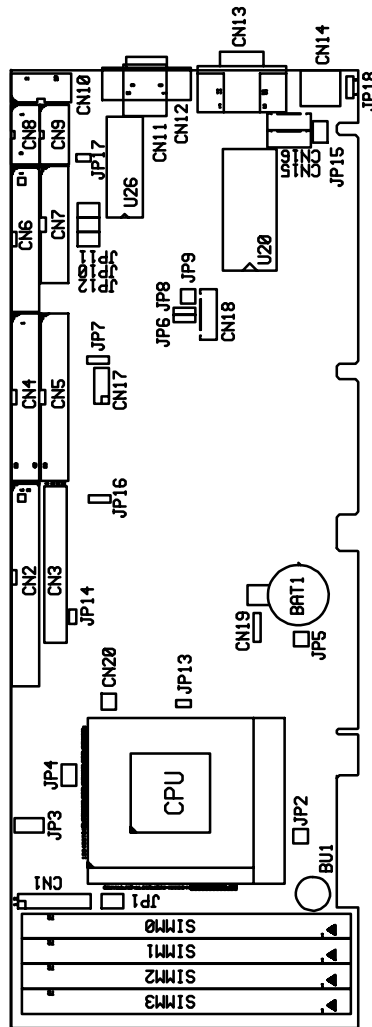

2.2 Jumper Settings

The **SBC8155** is configured to match the needs of your application by proper jumper settings. The following tables show the correct jumper settings for the onboard devices.

Jumper	Default Setting	Jumper Setting
JP1	CPU Clock Ration Selection: x3.5	Open
JP2	CPU Type Selection: Single Voltage CPU	Short 1-2, 3-4
JP3	CPU V _{core} Selection: 2.8V	Short 1-2
JP4	CPU Type Selection: Single Voltage CPU	Open
JP5	CPU Bus Clock Selection: 66MHz	Open
JP6	Power Supply Selection: AT Power Supply	Short 1-2
JP7	Power Supply Selection: AT Power Supply	Short 1-2
JP8	Watchdog Function: NMI	Short 1-2
JP9	DiskOnChip Memory Segment: E0000 – E3FFF	Short 1-2, 3-4
JP10	RS232/422/485 (COM2) Selection: RS-232	Short 1-2
JP11	RS232/422/485 (COM2) Selection: RS-232	Short 3-5, 4-6
JP12	RS232/422/485 (COM2) Selection: RS-232	Short 3-5, 4-6
JP16	Power Supply Selection: AT Power Supply	Short 1-2
JP17	RS232/422/485 (COM2) Selection: RS-232	Short 1-2
CN1	Use Internal Buzzer	Short 2-4

IMPORTANT: *The above default settings are set for Intel Pentium MMX 233 CPU use. Please refer to the following subsections when installing other types of microprocessors.*

2.2.1 CPU Settings

When a new CPU is to be installed, the related jumpers including CPU type, CPU Bus Clock, CPU Voltage, PCI Bus Clock, etc. may need to be adjusted.

2.2.1.1 CPU Bus Clock Selection: JP5

Options	Settings
60MHz	Short 1-2
66MHz (default)	Open



2.2.1.2 CPU Clock Ration Selection: JP1

Options	Settings	Options	Settings
x 1.5	Open	x 3.5 (default)	Open
x 2	Short 1-2	x 4	Short 1-2, 5-6
x 2.5	Short 1-2, 3-4	x 4.5	Short 1-2, 3-4, 5-6
x 3	Short 3-4	x 5	Short 3-4, 5-6
		x 5.5	Short 5-6

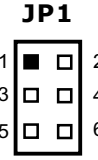

2.2.1.3 CPU V_{io} (V_{cc3}) Selection: JP2, JP4

Options	Settings
Single Voltage CPU: Intel P54C, Cyrix 6x86, AMD K5	JP2: Open JP4: Short 1-2, 3-4, 5-6
Dual Voltage CPU: Intel P55C (MMX), Cyrix 6x86L/6x86MX, AMD K6 (default)	JP2: Short 1-2, 3-4 JP4: Open

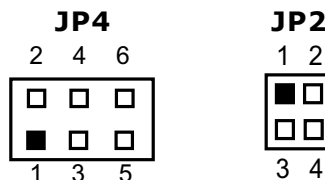

2.2.1.4 CPU V_{core} Selection: JP3

CPU Core Voltage	JP3 Settings			
	1-2	3-4	5-6	7-8
3.5V	Short	Short	Short	Short
3.4V	Short	Short	Short	Open
3.3V	Short	Short	Open	Short
3.2V	Short	Short	Open	Open
3.1V	Short	Open	Short	Short
3.0V	Short	Open	Short	Open
2.9V	Short	Open	Open	Short
2.8V (default)	Short	Open	Open	Open
2.7V	Open	Short	Short	Short
2.6V	Open	Short	Short	Open
2.5V	Open	Short	Open	Short
2.4V	Open	Short	Open	Open
2.3V	Open	Open	Short	Short
2.2V	Open	Open	Short	Open
2.1V	Open	Open	Open	Short
2.0V	Open	Open	Open	Open

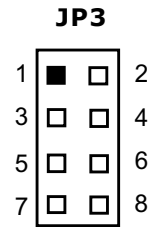

2.2.1.5 CPU Settings Reference

CPU Type	CPU Clock	Jumper Settings			
		JP1	JP5	JP3	JP2, JP4
Intel P54C					
Intel Pentium 90MHz	60MHz	Open	Short 1-2	Short 1-2, 3-4, 5-6, 7-8	JP2: Open JP4: Short 1-2, 3-4, 5-6
Intel Pentium 100MHz	66MHz	Open	Open	Short 1-2, 3-4, 5-6, 7-8	JP2: Open JP4: Short 1-2, 3-4, 5-6
Intel Pentium 120MHz	60MHz	Short 1-2	Short 1-2	Short 1-2, 3-4, 5-6, 7-8	JP2: Open JP4: Short 1-2, 3-4, 5-6
Intel Pentium 133MHz	66MHz	Short 1-2	Open	Short 1-2, 3-4, 5-6, 7-8	JP2: Open JP4: Short 1-2, 3-4, 5-6
Intel Pentium 166MHz	66MHz	Short 1-2, 3-4	Open	Short 1-2, 3-4, 5-6, 7-8	JP2: Open JP4: Short 1-2, 3-4, 5-6
Intel Pentium 200MHz	66MHz	Short 3-4	Open	Short 1-2, 3-4, 5-6, 7-8	JP2: Open JP4: Short 1-2, 3-4, 5-6
Intel P55C(MMX)					
Intel Pentium MMX 166MHz	66MHz	Short 1-2, 3-4	Open	Short 1-2	JP2: Short 1-2, 3-4 JP4: Open
Intel Pentium MMX 200MHz	66MHz	Short 3-4	Open	Short 1-2	JP2: Short 1-2, 3-4 JP4: Open
Intel Pentium MMX 233MHz	66MHz	Open	Open	Short 1-2	JP2: Short 1-2, 3-4 JP4: Open
Cyrix 6x86					
Cyrix P-150+	60MHz	Short 1-2	Short 1-2	Short 1-2, 3-4, 7-8	JP2: Open JP4: Short 1-2, 3-4, 5-6
Cyrix P-166+	66MHz	Short 1-2	Open	Short 1-2, 3-4, 7-8	JP2: Open JP4: Short 1-2, 3-4, 5-6
Cyrix 6x86MX					
Cyrix MMX PR-166	60MHz	Short 1-2, 3-4	Short 1-2	Short 1-2, 7-8	JP2: Short 1-2, 3-4 JP4: Open
Cyrix MMX PR-200	66MHz	Short 1-2, 3-4	Open	Short 1-2, 7-8	JP2: Short 1-2, 3-4 JP4: Open
Cyrix MMX PR-233	66MHz	Short 3-4	Open	Short 1-2	JP2: Short 1-2, 3-4 JP4: Open
Cyrix MMX PR-266	66MHz	Open	Open	Short 1-2	JP2: Short 1-2, 3-4 JP4: Open

Continued

CPU Type	CPU Clock	Jumper Settings			
		JP1	JP5	JP3	JP2, JP4
Cyrix 6x86L					
Cyrix 6x86L P-150	60MHz	Short 1-2	Short 1-2	Short 1-2	JP2: Short 1-2, 3-4 JP4: Open
Cyrix 6x86L P-166	66MHz	Short 1-2	Open	Short 1-2	JP2: Short 1-2, 3-4 JP4: Open
AMD K5					
AMD K5-PR90	60MHz	Open	Short 1-2	Short 1-2, 3-4, 7-8	JP2: Open JP4: Short 1-2, 3-4, 5-6
AMD K5-PR100	66MHz	Open	Open	Short 1-2, 3-4, 7-8	JP2: Open JP4: Short 1-2, 3-4, 5-6
AMD K5-PR120	60MHz	Short 1-2	Short 1-2	Short 1-2, 3-4, 7-8	JP2: Open JP4: Short 1-2, 3-4, 5-6
AMD K5-PR133	66MHz	Short 1-2	Open	Short 1-2, 3-4, 7-8	JP2: Open JP4: Short 1-2, 3-4, 5-6
AMD K5-PR166	66MHz	Short 1-2, 3-4	Open	Short 1-2, 3-4, 7-8	JP2: Open JP4: Short 1-2, 3-4, 5-6
AMD K6					
AMD K6-166	66MHz	Short 1-2, 3-4	Open	Short 1-2, 7-8	JP2: Short 1-2, 3-4 JP4: Open
AMD K6-200	66MHz	Short 3-4	Open	Short 1-2, 7-8	JP2: Short 1-2, 3-4 JP4: Open
AMD K6-233	66MHz	Open	Open	Short 1-2, 3-4	JP2: Short 1-2, 3-4 JP4: Open
AMD K6-266	66MHz	Short 1-2, 5-6	Open	Short 5-6	JP2: Short 1-2, 3-4 JP4: Open
AMD K6-300	66MHz	Short 1-2, 3-4, 5-6	Open	Short 5-6	JP2: Short 1-2, 3-4 JP4: Open
AMD K6-2					
AMD K6-2-333	66MHz	Short 3-4, 5-6	Open	Short 5-6	JP2: Short 1-2, 3-4 JP4: Open
AMD K6-2-366	66MHz	Short 5-6	Open	Short 5-6	JP2: Short 1-2, 3-4 JP4: Open
AMD K6-2-400	66MHz	Short 1-2	Open	Short 5-6, 7-8	JP2: Short 1-2, 3-4 JP4: Open
AMD K6-III					
AMD K6-III-400	66MHz	Short 1-2	Open	Short 3-4	JP2: Short 1-2, 3-4 JP4: Open

2.2.2 Power Supply Selection: JP6, JP7, JP16

Power Supply	Settings		
	JP6	JP7	JP16
ATX	Short 2-3	Short 2-3	Short 2-3
AT (default)	Short 1-2	Short 1-2	Short 1-2

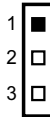

2.2.3 DiskOnChip® Memory Segment: JP9

Options	Settings
C8000 – CBFFF	Open
D0000 – D3FFF	Short 1-2
D8000 – DBFFF	Short 3-4
E0000 – E3FFF (default)	Short 1-2, 3-4

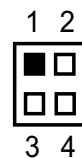

2.2.4 Watchdog Function: JP8

Options	Settings
NMI (default)	Short 1-2
Restart	Short 2-3

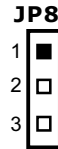

2.2.5 RS232/422/485 (COM2) Selection: JP10, JP11, JP12, JP17

JP10, JP11, JP12: RS-232/422/485 Selection

COM1 is fixed for RS-232 function only.

COM2 is selectable for RS-422, 485 function.

COM2 Function	Jumper Settings			
	JP10	JP11	JP12	JP17
RS-232 (default)	Short 1-2	Short 3-5, 4-6	Short 3-5, 4-6	Short 1-2
RS-422	Short 3-4	Short 1-3, 2-4	Short 1-3, 2-4	Open
RS-485	Short 5-6	Short 1-3, 2-4	Short 1-3, 2-4	Short

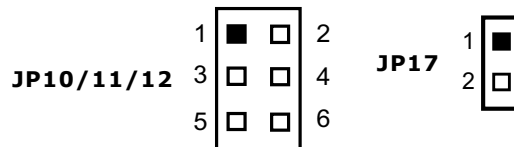

2.3 Connectors

The connectors allow the CPU card to connect with other parts of the system. Some problems encountered with your system may be caused by loose or improper connections. Ensure that all connectors are in place and firmly attached. The following tables list the function of each connector on the **SBC8155VES** CPU card. Their corresponding pin assignments will be described in Chapter 3.

2.3.1 SBC8155VES Connectors

Connectors	Label	Connectors	Label
General Output	CN1	RJ-45 LAN Connector	CN11
50-pin SCSI Connector	CN2	VGA Connector	CN13
68-pin SCSI	CN3	Keyboard DIN	CN14
IDE1 Connector	CN4	External Keyboard	CN15
IDE2 Connector	CN5	External PS/2 Mouse	CN16
FDD Connector	CN6	IrDA Connector	CN17
LPT Connector	CN7	ATX Control Connector	CN18
COM1 Connector	CN8	Int./Ext. Battery Select	CN19
COM2 Connector	CN9	CPU Fan Connector	CN20
USB Connector	CN10		

2.3.2 SBC8155V Connectors

Connectors	Label	Connectors	Label
General Output	CN1	VGA Connector	CN13
IDE1 Connector	CN4	Keyboard DIN	CN14
IDE2 Connector	CN5	External Keyboard	CN15
FDD Connector	CN6	External PS/2 Mouse	CN16
LPT Connector	CN7	IrDA Connector	CN17
COM2 Connector	CN9	ATX Control Connector	CN18
USB Connector	CN10	Int./Ext. Battery Select	CN19
COM1 DB9 Connector	CN12	CPU Fan Connector	CN20

2.3.3 SBC8155 Connectors

Connectors	Label	Connectors	Label
General Output	CN1	Keyboard DIN	CN14
IDE1 Connector	CN4	External Keyboard	CN15
IDE2 Connector	CN5	External PS/2 Mouse	CN16
FDD Connector	CN6	IrDA Connector	CN17
LPT Connector	CN7	ATX Control Connector	CN18
COM2 Connector	CN9	Int./Ext. Battery Select	CN19
USB Connector	CN10	CPU Fan Connector	CN20
COM1 DB9 Connector	CN12		

2.3.4 SBC8155VE Connectors

Connectors	Label	Connectors	Label
General Output	CN1	VGA Connector	CN13
IDE1 Connector	CN4	Keyboard DIN	CN14
IDE2 Connector	CN5	External Keyboard	CN15
FDD Connector	CN6	External PS/2 Mouse	CN16
LPT Connector	CN7	IrDA Connector	CN17
COM1 Connector	CN8	ATX Control Connector	CN18
COM2 Connector	CN9	Int./Ext. Battery Select	CN19
USB Connector	CN10	CPU Fan Connector	CN20
RJ-45 LAN Connector	CN11		

2.3.5 Improvised Connectors

2.3.5.1 ATX Power Switch/Soft Power Switch/SMI Switch

A momentary switch, connected to this lead (**CN18**), controls the system power. Refer to Section 5.8 “Soft-Off by PWR-BTTN” option and the Power ON Function on section 5.10 for detailed description of this switch.

NOTE: This connector functions only with an ATX power supply.

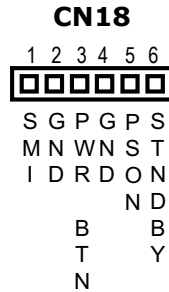

2.3.5.2 General Output Connector

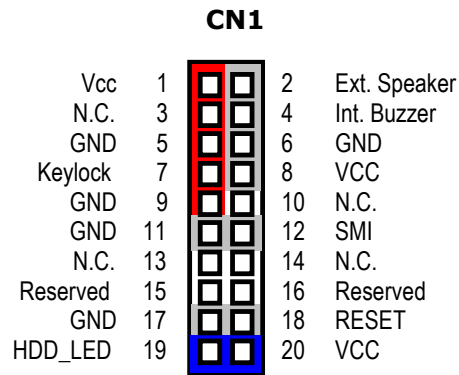

Power LED/KeyLock Switch

This 5-pin connector, designated at **Pins 1, 3, 5, 7 and 9 of CN1**, connects the system power LED indicator and keyboard lock to their respective switches on the case. The Power LED lights up when the system is powered ON and blinks when it is in Sleep mode. KeyLock switch enables the keyboard locking function of the **SBC8155**.

Speaker Connector

Pins 2, 4, 6, and 8 of CN1 is a 4-pin connector that connects to the case-mounted speaker unit.

SMI Switch

This switch enables the connection between the **SBC8155**-based system and the installed hardware. Aside from the SMI Switch featured in the previous section, **Pins 11 & 12 of CN1** also support the SMI switch function. Refer to Sections 5.8 for a detailed description of its function.

Reset Switch

Pins 17 & 18 of CN1 connect to the case-mounted reset switch and allow rebooting of your computer instead of turning OFF the power switch. This is a preferred method of rebooting in order to prolong the life of the system's power supply.

HDD LED

This connector extends to the hard drive activity LED on the control panel. This LED will flash when the HDD is being accessed. **Pins 19 & 20 of CN1** connect the hard disk drive and the front panel HDD LED.

This page does not contain any information.

Chapter 3

Installation

This chapter describes the hardware installation procedures on the **SBC8155** all-in-one Pentium CPU cards.

The following is a list of typical peripherals required to build a minimum system:

- Power supply and passive backplane (optional)
- IBMTM PC/AT keyboard
- Display monitor
- Floppy or hard disk with MS-DOS or Flash Disk emulator

3.1 System Memory

SBC8155 has four onboard 72-pin SIMM sockets, able to support 512Kx36, 1Mx36, 2Mx36, 4Mx36, 8Mx36, and 16Mx36 SIMM modules, providing the user with up to 256MB system memory. It also supports non-parity SIMM DRAM. When using SIMM DRAM, disable the "memory-parity-check item" on your BIOS utility program. The DRAM controller supports auto-insert error debug, auto-detect DRAM size and bank.

3.1.1 System Memory Installation

You can install from 4MB- up to 64-MB memory onboard using 2/4/8/16/32 or 64 MB 72-pin FPM/EDO SIMM modules.

1. Ensure that all power to the system are switched OFF.
2. Insert the first SIMM edge connector at a 45° angle into the SIMM1 socket. The SIMM modules must face the CPU. The SIMMs are latched and will only go in one direction.
3. Carefully push the SIMM towards the CPU until the locking tabs at the side snaps into place.
4. Check to make sure the SIMM is inserted securely.
5. Repeat Steps 2-4 for SIMM 2.

3.2 CPU Installation

1. Align pin one (white dot) on the CPU with pin one of the socket. Pin one of the CPU socket may either be marked on the board or indicated by an arrow sign on the base of the socket. Normally, its diagonal corner distinguishes pin one on the socket.
2. To complete the CPU installation, gently press the CPU into place.
3. Double-check the insertion and orientation of the CPU before applying power. Improper installation will result in permanent damage to the CPU.

3.3 Configuring Power Supply

3.3.1 ATX Power Supply

Follow these instructions if the system has an ATX power supply installed.

1. Install the ATX Power Control Connector cable to the designated ATX power control connector on your backplane. The ATX Power Control Connector cable is a 6-pin cable that comes with the **SBC8155** packaging.
2. Configure the proper jumper settings by setting JP6, JP7 and JP16 to Short 2-3.

3.3.2 AT Power Supply

When using an AT power supply in your system, there is only one step to follow.

1. Configure the proper jumper settings by setting JP6, JP7 and JP16 to Short 1-2.

3.4 Completing Installation

To complete the installation, the following steps should be followed:

1. Make sure the power is OFF.
2. Set the configuration jumpers according to the jumper setting on Chapter 2.
3. Install the **SBC8155** CPU card into one of the slots on the passive backplane. You may allow the **SBC8155** to stand alone as a single board computer.
4. Connect the I/O cables and peripherals, i.e. floppy disk, hard disk, monitor, keyboard, power supply and etc. to the CPU board.

NOTE: *The color of pin one is usually red or blue, while others are gray.*

5. Turn ON the system power.

This page does not contain any information.

Chapter 4

Hardware Description

This chapter gives a detailed explanation of the hardware features onboard the **SBC8155** all-in-one Pentium CPU cards.

4.1 CPU

The **SBC8155** supports Intel Pentium, AMD K5/K6/K6-2/K6-III, Cyrix 6x86 CPUs. Systems based on these CPUs can be operated under UNIX, OS/2, Windows NT, Windows 95 and MS-DOS environments. The system's performance depends on the installed CPU on the board. When installing a new CPU, the jumpers including CPU type, CPU Clock, CPU Voltage and PCI Bus Clock may need to be adjusted. Make sure all the settings are correct for the installed CPU to prevent any damage to the CPU.

4.2 BIOS

The system BIOS used in **SBC8155** is Award Plug and Play BIOS. The **SBC8155** contains a single SST 29EE020 Flash EPROM.

4.3 I/O Port Address Map

The CPU card communicates via I/O ports. It has a total of 1KB port addresses that can be assigned to other devices via I/O expansion cards.

Address	Devices
000-01F	DMA controller #1
020-03F	Interrupt controller #1
040-05F	Timer
060-06F	Keyboard controller

Continued

Address	Devices
070-07F	Real time clock, NMI
080-09F	DMA page register
0A0-0BF	Interrupt controller #2
0F0	Clear math coprocessor busy signal
0C0-0DF	DMA controller #2
0F1	Reset math coprocessor
0F8-0FF	Math processor
120	Disable watchdog timer operation (read)
121	Enable watchdog timer operation (read)
122	Watchdog
1F0-1F8	Fixed disk controller
200-207	Game port
300-31F	Prototype card
360-36F	Reserved
378-37F	Parallel port #1
380-38F	SDLC #2
3A0-3AF	SDLC #1
3B0-3BF	MDA video card (including LPT1)
3C0-3CF	EGA card
3D0-3DF	CGA card
3F0-3F7	Floppy disk controller
3F8-3FF	Serial port #1 (COM1)
2F8-2FF	Serial port #2 (COM2)
3F0	Winbond I/O

4.4 Interrupt Controller

The **SBC8155** is a fully PC compatible control board. It consists of 16 ISA interrupt request lines and 4 of the 16 can be either ISA or PCI. The mapping list of the 16 interrupt request lines is shown below;

NMI	Parity check error
IRQ0	System timer output
IRQ1	Keyboard
IRQ2	Interrupt rerouting from IRQ8 through IRQ15
IRQ3	Serial port #2
IRQ4	Serial port #1
IRQ5	Reserved
IRQ6	Floppy disk controller
IRQ7	Parallel port #1
IRQ8	Real time clock
IRQ9	Reserved
IRQ10	Reserved (onboard SCSI)
IRQ11	USB and [and onboard Network]
IRQ12	PS/2 Mouse
IRQ13	Math coprocessor
IRQ14	Primary IDE channel
IRQ15	Secondary IDE Channel

*"()": standard specifications on the **SBC8155VES** card only; using IRQ10 for SCSI adapter.*

*"[]": standard specifications for **SBC8155VES** & **SBC8155VE** only; using shared IRQ11 for USB and Ethernet.*

4.5 IDE Interface Connector

The **SBC8155** includes a 2-channel PCI bus enhanced IDE controller which can support master/slave mode and post write transaction mechanisms with 64-byte buffer, and master data transaction. This feature, connected via connectors **CN4** and **CN5**, allows the **SBC8155** to handle 4 IDE drives. Refer to Appendix B for the pinout assignments of **CN4** and **CN5**.

4.6 VGA Interface Connector

CN13 onboard **SBC8155** is a connector supporting CRT VGA panel displays. **CN13** is a standard 15-pin pin header connector commonly used for CRT VGA display. Configuration of the VGA interface is done via the software utility and no jumper setting is required. See Appendix B for the pin assignment of **CN13**.

4.7 Floppy Disk Controller

The **SBC8155** provides a 34-pin header type connector, **CN6**, supporting up to two floppy drives. The floppy drives may be any one of the following types: 5.25" 360KB/1.2MB and 3.5" 720KB/1.44MB/2.88MB. The **CN6** pin assignment is listed in Appendix B.

4.8 Parallel Port Interface

The **SBC8155** onboard **CN7** is a multi-mode parallel port able to support:

- **Standard mode:** IBM PC/XT, PC/AT and PS/2TM compatible with bi-directional parallel port
- **Enhanced mode:** Enhance parallel port (EPP) compatible with EPP 1.7 and EPP 1.9 (IEEE 1284 compliant)
- **High speed mode:** Microsoft and Hewlett Packard extended capabilities port (ECP) IEEE 1284 compliant

The address select of the onboard parallel port in LPT1 (3BCH), LPT2 (378H), LPT3 (278H) or disabled is done by BIOS CMOS setup.

4.9 Serial Port Interface

The serial interface onboard **SBC8155** consists of COM1 port supports RS-232 and COM2 provide RS-232/422/485 connectivity.

4.9.1 Serial Ports IRQ Selection

COM1 and COM2 on **SBC8155VES** and **SBC8155VE** CPU cards have two 10-pin connectors, **CN8** and **CN9**. **SBC8155V** and **SBC8155**, on the other hand, use a 10-pin connector for COM2 (**CN9**) and a DB9-pin connector for COM1 (**CN12**). Interrupt Requests on COM1 and COM2 for all **SBC8155** CPU cards are selected via IRQ4 and IRQ3 respectively. Additionally, both ports can be enabled or disabled via BIOS setting. The RS-232 pin assignments for COM1 and COM2 along with the RS-485 pin assignments for COM2 are in Appendix B.

4.10 Keyboard and PS/2 Mouse Connectors

The **SBC8155** provides a keyboard (**CN15**) and PS/2 (**CN16**) mouse Interface with a 5-pin connector. **CN14** is a DIN connector for PS/2 keyboard connection. The pin assignments of the keyboard/mouse are shown in Appendix B.

4.11 USB Connector

The Universal Serial Bus (USB) connector on the **SBC8155** is for installation of peripherals supporting the USB interface. **CN10** is the 10-pin USB connector on the **SBC8155**.

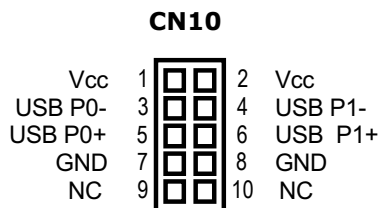

4.12 Ethernet Connector

The RJ-45 connector is used for Ethernet. To connect the **SBC8155VES** and **SBC8155VE** to 10-Base-T or 100-Base-T hub, just plug one end of the cable into the **CN11** and connect the other end (phone jack) of the cable to a 10-Base-T hub.

NOTE: *This connector comes with the **SBC8155VES** & **SBC8155VE** only.*

4.13 SCSI Connectors

CN2 and **CN3** of **SBC8155VES** provide a powerful multitasking interface between your computer PCI bus and SCSI devices (disk drives, CD-ROM drives, scanners, tape backups, removable media drives, etc.) through the onboard Adaptec Ultra SCSI controller. **CN2** is a 50-pin connector for 8-bit SCSI devices whereas **CN3** is a 68-pin connector for installation of 16-bit Ultra Wide SCSI devices.

NOTE: *This connector comes with the **SBC8155VES** only.*

4.14 IrDA Connector

CN17 is a 10-pin connector is used for an IrDA connector for wireless communication.

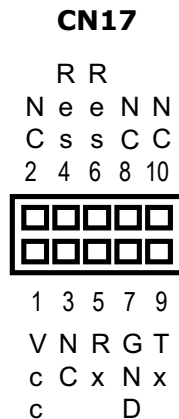

4.15 External/Internal Battery Select

CN19 is a 4-pin connector that allows the user to connect an external battery to maintain the information stored in the CMOS RAM in case the built-in battery malfunctions. The default is set to Internal Battery with a jumper connecting pins 2 and 3. When using an external battery, connect the external battery to pins 1 and 4 of **CN19** and leave pins 2 and 3 *open*.

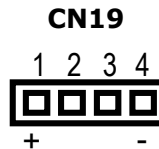

4.16 CPU Fan Connector

CN20 is a CPU fan connector. Pentium CPUs require a fan for heat dispensing. A fan connector is thus designed on the **SBC8155** to provide the fan power. Its pin assignment is listed on Appendix B.

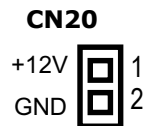

NOTE: *When the CPUFAN Off in Suspend option within the Power Management Setup is **enabled**, the CPU cooling fan turns OFF simultaneous to the system's entry to Suspend mode. See Section 5.8 for more information.*

This page does not contain any information.

Chapter 5

Display Drivers

5.1 General Description

The VGA interface for **SBC8155** supports CRT VGA display. From the Product Information CD-ROM, you may copy/install the drivers matching the operating system installed on your computer. The operating systems supported are as follows:

5.2 Features

- Cirrus Logic GD5446 CRT VGA PCI local-bus controller with 2MB display DRAM
- Supports up to 1280 x 1024 resolution

5.3 Drivers Supported

- DOS Driver
- Win95
- Winnt3.5
- Winnt4.0
- Windows 3.1
- OS/2 Warp

NOTE: *For more details, please refer to the README files in the Product Information CD-ROM's VGA folder.*

This page does not contain any information.

Chapter 6

Ethernet

6.1 General Description

The **SBC8155** is equipped with a high performance PCI interface which is fully compliant with the IEEE 802.3 standard, and consisting of a RJ-45 connector (**CN11**).

6.2 Features

- 10Mb/s and 100Mb/s operations
- Supports 10Mb/s and 100Mb/s N-Way auto negotiation
- Full duplex capability
- Full compliance with PCI Revision 2.1
- PCI Bus Master data transfers

6.3 Drivers Supported

Bundled with popular software drivers, the **SBC8155** Ethernet interface allows great flexibility to work with all major networking operating systems including Novell NetWare v2.x, v3.x, v4.x, Microsoft LAN Manager, Win3.1, Win NT, Win95, IBM LAN Server, SCO UNIX or other ODI, NDIS and Packet drive compliant operating systems. For more detailed information, refer to the *HELP8139.EXE* file in the Product Information CD-ROM.

This page does not contain any information.

Chapter 7

Award BIOS Utility

The Award BIOS ROM has a built-in Setup program that allows users to modify the basic system configuration. This type of information is stored in a battery-backed RAM (CMOS RAM) that retains the Setup information each time the power is turned off.

7.1 Entering Setup

There are two ways to enter the Setup program. You may either turn on the computer and press immediately, or press the and/or <Ctrl>, <Alt>, and <Esc> keys simultaneously when the following message appears at the bottom of the screen during POST (Power On Self Test).

TO ENTER SETUP PRESS DEL KEY

If the message disappears before you respond and you still wish to enter Setup, restart the system and try again. This is possible by turning the system power to OFF then to ON, pressing the "RESET" button on the system case, or by simultaneously pressing <Ctrl>, <Alt>, and keys. If you do not press the keys at the correct time and the system does not boot, an error message will be displayed and you will be prompted with the following:

PRESS <F1> TO CONTINUE, <CTRL-ALT-ESC> OR TO ENTER SETUP

7.2 Control Keys

Up arrow	Moves cursor to the previous item
Down arrow	Moves cursor to the next item
Left arrow	Moves cursor to the item on the left hand
Right arrow	Move to the item in the right hand
Esc key	Main Menu -- Quits and deletes changes into CMOS Status Page Setup Menu and Option Page Setup Menu -- Exits current page and returns to Main Menu
PgUp/"+" key	Increases the numeric value or makes changes
PgDn/"-" key	Decreases the numeric value or makes changes
F1 key	General help, only for Status Page Setup Menu and Option Page Setup Menu
(Shift) F2 key	Change color from total 16 colors. F2 to select color forward, (Shift) F2 to select color backward
F3 key	Reserved
F4 key	Reserved
F5 key	Restores the previous CMOS value from CMOS, only for Option Page Setup Menu
F6 key	Loads the default CMOS value from BIOS default table, only for Option Page Setup Menu
F7 key	Loads the Setup default , only for Option Page Setup Menu
F8 key	Reserved
F9 key	Reserved
F10 key	Saves all the CMOS changes, only for Main Menu

7.3 Getting Help

- **Main Menu**
The on-line description of the highlighted setup function is displayed at the bottom of the screen.
- **Status Page Setup Menu/Option Page Setup Menu**
Press <F1> to pop up a small help window that describes the appropriate keys to use and the possible selections for the highlighted item. To exit the Help Window press <F1> or <Esc>.

7.4 The Main Menu

Once you enter the Award BIOS CMOS Setup Utility, the Main Menu will appear on the screen. The Main Menu allows you to select from ten setup functions and two exit choices. Use the arrow keys to select the setup function you intend to configure then press <Enter> to accept or enter its sub-menu.

**ROM PCI/ISA BIOS (2A59IA59)
CMOS SETUP UTILITY
AWARD SOFTWARE, INC.**

STANDARD CMOS SETUP	INTEGRATED PERIPHERALS
BIOS FEATURES SETUP	SUPERVISOR PASSWORD
CHIPSET FEATURES SETUP	USER PASSWORD
POWER MANAGEMENT SETUP	IDE HDD AUTO DETECTION
PNP/PCI CONFIGURATION	HDD LOW LEVEL FORMAT
LOAD BIOS DEFAULTS	SAVE & EXIT SETUP
LOAD SETUP DEFAULTS	EXIT WITHOUT SAVING
Esc : Quit	↑ ↓ → ← : Select Item
F10 : Save & Exit Setup	(Shift) F2 : Change Color
Time, Date Hard Disk Type...	

- **Standard CMOS Setup**
This setup option includes all the items in a standard compatible BIOS.
- **BIOS Features Setup**
This setup page includes all the items of Award special enhanced features.
- **Chipset Features Setup**
This setup option includes all the items of chipset special features.
- **Power Management Setup**
This category determines the power consumption of the system after selecting its items. Default value is Disabled.
- **PnP/PCI Configuration**
This category specifies the assignment of all IRQs and DMAs.

- **Load BIOS Defaults**
BIOS defaults indicate the most appropriate values of the system parameter in which the system can operate at a minimum performance.
- **Load Setup Defaults**
Chipset defaults indicate the values required by the system for maximum performance.
- **Integrated Peripherals**
This page allows you to set up all the on board I/O controllers like IDE, SCSI, FDC, etc..
- **Supervisor / User Passwords**
Changes, sets or disables password of Supervisor or User. It allows you to restrict access to the system and Setup, or just to Setup.
- **IDE HDD Auto Detection**
Automatically configures hard disk parameters.
- **HDD Low Level Format**
Hard disk low level format utility.
- **Save & Exit Setup**
Saves CMOS value changes to CMOS and exits setup.
- **Exit Without Saving**
Abandons all CMOS value changes and exits setup.

7.5 Standard CMOS Setup Menu

The items in Standard CMOS Setup Menu are divided into 10 categories. Each category includes no, one or more than one setup items. Use the arrow keys to highlight the item and then use the <PgUp> or <PgDn> keys to select the value you want in each item.

**ROM PCI/ISA BIOS (2A59IA59)
STANDARD CMOS SETUP
AWARD SOFTWARE, INC.**

Date (mm:dd:yy) : Fri, Jul 18 1997								
Time (hh:mm:ss) : 00:00:00								
HARD DISKS	TYPE	SIZE	CYLS	HEAD	PRECOMP	LANDE	SECTOR	MODE
Primary Master:	Auto	0	0	0	0	0	0	-----
Primary Slave:	Auto	0	0	0	0	0	0	-----
Secondary Master:	Auto	0	0	0	0	0	0	-----
Secondary Slave:	Auto	0	0	0	0	0	0	-----
Drive A	: 1.44M , 3.5 in					Base Memory : 640K		
Drive B	: None					Extended Memory : 14336K		
Video	: EGA / VGA					Other Memory : 384K		
Halt On	: All Errors					Total Memory : 15360K		
ESC : Quit			↑ ↓ → ← : Select Item]			PU / PD / + / - : Modify		
F1 : Help			(Shift) F2 : Change Color					

- **Date**

The date format is <day>, <date> <month> <year>. Press <F3> to show the calendar.

day	The day of week, from Sun to Sat, determined by the BIOS, is read only
date	The date, from 1 to 31 (or the maximum allowed in the month), can key in the numerical / function key
month	The month, Jan through Dec.
year	The year, depends on the year of BIOS

- **Time**

The time format is <hour> <minute> <second> accepting both function key or numerical key. The time is calculated based on the 24-hour military-time clock. For example, 1 p.m. is 13:00:00.

- **Primary Master/Primary Slave/Secondary Master/Secondary Slave**

The categories identify the types of one channel that have been installed in the computer. There are 45 predefined types and 2 user definable types are for Enhanced IDE BIOS. Type 1 to Type 45 are predefined. Type User is user-definable.

Press <PgUp>/<+> or <PgDn>/<-> to select a numbered hard disk type or type the number and press <Enter>. Note that the specifications of your drive must match with the drive table. The hard disk will not work properly if you enter improper information within this category. If your hard disk drive type does not match or is not listed, you can use Type User to define your own drive type manually.

If you select Type User, related information is asked to be entered to the following items. Enter the information directly from the keyboard and press <Enter>. This information should be provided in the documentation from your hard disk vendor or the system manufacturer.

If the controller of HDD interface is ESDI, select "Type 1".

If the controller of HDD interface is SCSI, select "None".

If the controller of HDD interface is CD-ROM, select "None".

CYLS.	number of cylinders	LANDZONE	landing zone
HEADS	number of heads	SECTORS	number of sectors
PRECOMP	write precom	MODE	HDD access mode

If there is no hard disk drive installed, select NONE and press <Enter>.

- **Drive A type/Drive B type**

The category identifies the types of floppy disk drive A or drive B installed in the computer.

None	No floppy drive installed
360K, 5.25 in	5.25 inch PC-type standard drive; 360Kb capacity
1.2M, 5.25 in	5.25 inch AT-type high-density drive; 1.2MB capacity
720K, 3.5 in	3.5 inch double-sided drive; 720Kb capacity
1.44M, 3.5 in	3.5 inch double-sided drive; 1.44MB capacity
2.88M, 3.5 in	3.5 inch double-sided drive; 2.88MB capacity

- **Video**

The category selects the type of adapter used for the primary system monitor that must match your video display card and monitor. Although secondary monitors are supported, you do not have to select the type in Setup. You have two ways to boot up the system:

1. When VGA as primary and monochrome as secondary, the selection for the video type is "VGA Mode".
2. When monochrome as primary and VGA as secondary, the selection of the video type is "Monochrome Mode".

EGA/VGA	Enhanced Graphics Adapter/Video Graphics Array. For EGA, VGA, SEGA, or PGA monitor adapters.
CGA 40	Color Graphics Adapter, power up in 40 column mode
CGA 80	Color Graphics Adapter, power up in 80 column mode
MONO	Monochrome adapter, includes high resolution monochrome adapters

- **Error halt**

The category determines whether the computer will stop if an error is detected during power up.

No errors	Whenever the BIOS detects a non-fatal error, the system will halt and you will be prompted.
All errors	The system boot will not stop for any error detected.
All, But Keyboard	System boot will not stop for a keyboard error; it will stop for all other errors.
All, But Diskette	System boot will not stop for a disk error; it will stop for all other errors.
All, But Disk/Key	System boot will not stop for a keyboard or disk error; it will stop for all other errors.

- **Memory**

The category is display-only which is determined by POST (Power On Self Test) of the BIOS.

- **Base Memory**

The POST of the BIOS will determine the amount of base (or conventional) memory installed in the system. The value of the base memory is typically 512K for systems with 512K memory installed on the motherboard, or 640K for systems with 640K or more memory installed on the motherboard.

■ **Extended Memory**

The BIOS determines how much extended memory is present during the POST. This is the amount of memory located above 1MB in the CPU's memory address map.

■ **Other Memory**

This refers to the memory located in the 640K to 1024K address space. This is memory that can be used for different applications. DOS uses this area to load device drivers to keep as much base memory free for application programs. Most use for this area is Shadow RAM.

■ **Total Memory**

System total memory is the sum of basic memory, extended memory, and other memory.

7.6 BIOS Features Setup Menu

ROM PCI/ISA BIOS (2A59IA59)
BIOS FEATURES SETUP
 AWARD SOFTWARE, INC.

Virus Warning	:Disabled	Video BIOS Shadow	:Enabled
CPU Internal Cache	:Enabled	C8000-CBFFF Shadow	:Disabled
External Cache	:Enabled	CC000-CFFFF Shadow	:Disabled
Quick Power On Self Test	:Enabled	D0000-D3FFF Shadow	:Disabled
Boot Sequence	:A,C,SCSI	D4000-D7FFF Shadow	:Disabled
Swap Floppy Drive	:Disabled	D8000-DBFFF Shadow	:Disabled
Boot Up Floppy Seek	:Enabled	DC000-DFFFF Shadow	:Disabled
Boot Up NumLock Status	:On		
Boot Up System Speed	:High		
Gate A20 Option	:Fast		
Typematic Rate Setting	:Disabled		
Typematic Rate(Chars/Sec)	:6	ESC : Quit	↑ ↓ → ← : Select
Typematic Delay (Msec)	:250	Item	
Security Option	:Setup	F1 : Help	PU/PD/+/- : Modify
PCI/VGA Palette Snoop	:Disabled	F5 : Old Values	(Shift) F2 : Color
OS Select for DRAM >64MB	:Non-OS2	F6 : Load BIOS Defaults	
		F7 : Load Setup Defaults	

● **Virus Warning**

This option flashes on the screen. During and after the system boot up, any attempt to write to the boot sector or partition table of the hard disk drive will halt the system with the following message. You can run an anti-virus program to locate the problem. The default setting is "Disabled".

<p>! WARNING ! <i>Disk boot sector is to be modified Type "Y" to accept write or "N" to abort write Award Software, Inc.</i></p>

Enabled	Activates automatically when the system boots up causing a warning message to appear when there is an attempt to access the boot sector or hard disk partition table.
Disabled	No warning message will appear when attempts to access the boot sector or hard disk partition table are made.

NOTE: *This function is only available with DOS and other operating systems that do not trap INT13.*

- **CPU Internal Cache/External Cache**

These two options speed up memory access. However, it depends on the CPU/chipset design. The default setting is "Enabled". CPUs with no built-in internal cache will not provide the "CPU Internal Cache" item on the menu.

Enabled	Enable cache
Disabled	Disable cache

- **Quick Power On Self Test**

This option speeds up Power On Self Test (POST) after you turn on the system power. If set as Enabled, BIOS will shorten or skip some check items during POST. The default setting is "Enabled".

Enabled	Enable Quick POST
Disabled	Normal POST

- **Boot Sequence**

The original IBM PCs load the DOS operating system from drive A (floppy disk), so IBM PC-compatible systems are designed to search for an operating system first on drive A, and then on drive C (hard disk). However, the BIOS now offers 11 different boot sequence options of three drives each. In addition to the traditional drives A and C, options include IDE hard drives D, E, and F; plus a SCSI hard drive and a CD-ROM drive. This category determines from which drive the computer searches first for the disk operating system (i.e., DOS). Default value is "A,C,SCSI".

A,C,SCSI	System searches for the operating system from the floppy disk drive. If it fails, it will search from the hard disk drive. If operating system is still not found, it'll seek from the SCSI device.
C,A,SCSI	System searches for the operating system from the hard disk drive first. If it fails, it will search from the floppy disk drive. If operating system is still not found, it'll seek from the SCSI device.
C,CDROM,A	System searches for the operating system from the hard disk drive first. If it fails, it will search from the IDE CDROM drive. If operating system is still not found, it'll seek from the floppy disk drive.
CDROM,C,A	System searches for the operating system from the IDE CDROM drive first. If it fails, it will search from the hard disk drive. If operating system is still not found, it'll seek from the floppy disk drive.
D,A,SCSI	System searches for the operating system from the second IDE HDD first. If it fails, it will search from the floppy disk drive. If operating system is still not found, it'll seek from the SCSI device.
E,A,SCSI	System searches for the operating system from the third IDE HDD first. If it fails, it will search from the floppy disk drive. If operating system is still not found, it'll seek from the SCSI device.
F,A,SCSI	System searches for the operating system from the fourth IDE HDD first. If it fails, it will search from the floppy disk drive. If operating system is still not found, it'll seek from the SCSI device.
SCSI,A,C	System searches for the operating system from the SCSI device first. If it fails, it will search from the floppy disk drive. If operating system is still not found, it'll seek from the first IDE HDD.
SCSI,C,A	System searches for the operating system from the SCSI device first. If it fails, it will search from the first IDE HDD. If operating system is still not found, it'll seek from the floppy disk drive.
C only	System only searches for the operating system from the first IDE HDD.
LS/ZIP,C	System searches for the operating system from the 120MB LS floppy or the 100MB ZIP drive first. If it fails, it'll search from the first IDE HDD.

- **Boot Up Floppy Seek**

During POST, BIOS will determine the floppy disk drive type, 40 or 80 tracks, installed in the system. 360Kb type is 40 tracks while 720Kb, 1.2MB and 1.44MB are all 80 tracks. The default value is "Enabled".

Enabled	BIOS searches for floppy disk drive to determine if it is 40 or 80 tracks. Note that BIOS can not tell from 720K, 1.2M or 1.44M drive type as they are all 80 tracks.
Disabled	BIOS will not search for the type of floppy disk drive by track number. There will be no warning message displayed if the drive installed is 360K.

- **Boot Up NumLock Status**

This option enables and disables the numberlock function of the keypad. The default value is "On".

On	Keypad functions confine with numbers
Off	Keypad functions convert to special functions (i.e., left/right arrow keys)

- **Boot Up System Speed**

It selects the default system speed - the speed that the system will operate immediately after power up. The default value is "High".

High	Sets the speed to high
Low	Sets the speed to low

- **Gate A20 Option**

The default value is "Fast".

Normal	The A20 signal is controlled by keyboard controller or chipset hardware.
Fast	Default: Fast. The A20 signal is controlled by Port 92 or chipset specific method.

- **Typematic Rate Setting**

This determines the typematic rate of the keyboard. The default value is "Disabled".

Enabled	Enable typematic rate and typematic delay programming
Disabled	Disable typematic rate and typematic delay programming. The system BIOS will use default value of these 2 items and the default is controlled by keyboard.

- **Typematic Rate (Chars/Sec)**

This option refers to the number of characters the keyboard can type per second. The default value is "6".

6	6 characters per second
8	8 characters per second
10	10 characters per second
12	12 characters per second
15	15 characters per second
20	20 characters per second
24	24 characters per second
30	30 characters per second

- **Typematic Delay (Msec)**

This option sets the display time interval from the first to the second character when holding a key. The default value is "250".

250	250 msec
500	500 msec
750	750 msec
1000	1000 msec

- **Security Option**

This item allows you to limit access to the system and Setup, or just to Setup. The default value is "Setup".

System	The system will not boot and access to Setup will be denied if the incorrect password is entered at the prompt.
Setup	The system will boot, but access to Setup will be denied if the correct password is not entered at the prompt.

NOTE: *To disable security, select PASSWORD SETTING at Main Menu and then you will be asked to enter password. Do not type anything, just press <Enter> and it will disable security. Once the security is disabled, the system will boot and you can enter Setup freely.*

- **OS Select for DRAM >64**

This segment is specifically created for OS/2 when DRAM is larger than 64MB. If your operating system is OS/2 and DRAM used is larger than 64MB, you have to select "OS 2", otherwise (under non-OS2), default is NON-OS2. The default value is "Non-OS2".

- **Video BIOS Shadow**

Video shadowing increases the video speed by copying the video BIOS into RAM. However, it is still optional depending on the chipset design. The default value of this option is "Enabled".

Enabled	Video BIOS shadowing is enabled
Disabled	Video BIOS shadowing is disabled

- **C8000 - CBFFF Shadow/DC000 - DFFFF Shadow**

These options determine whether optional ROM will be copied to RAM by 16K byte or 32K byte per/unit. The default value for all is "Disabled".

Enabled	Optional shadow is enabled
Disabled	Optional shadow is disabled

- NOTE:**
1. For C8000-DFFFF option-ROM on PCI BIOS – BIOS automatically enables the shadow RAM. User does not have to select the item.
 2. IDE second channel control:
Enable: enables secondary IDE port and BIOS will assign IRQ15 for this port.
Disable: disables secondary IDE port and IRQ15 is available for other device(s). The item is optional only for PCI BIOS.
 3. Some sound cards have an onboard CD-ROM controller that uses IDE Secondary Port. To avoid PCI IDE conflict, disable the IDE secondary channel control so that the CD-ROM may work.

7.7 Chipset Features Setup Menu

Since the features in this section are related to the chipset on the CPU board and are completely optimized, you are not recommended to change the default settings in this setup table unless you are well oriented with the chipset features.

**ROM PCI/ISA BIOS (2A5IIN0G)
CHIPSET FEATURES SETUP
AWARD SOFTWARE INC.**

Auto Configuration	: Disabled	DRAM Refresh Rate	: 15.6 us
DRAM Timing	: 60ns	Power-Supply Type	: AT
DRAM Leadoff Timing	: 10/6/3	CPU Warning Temperature	: Disabled
DRAM Read Burst (EDO/FP)	: x222/x333	Current CPU Temperature	: 29°C/84°F
DRAM Write Burst Timing	: x222		
Fast EDO Lead Off	: Disabled		
Refresh RAS# Assertion	: 4 Clks		
Fast RAS to CAS Delay	: 3		
DRAM Page Idle Timer	: 2 Clks		
DRAM Enhanced Paging	: Enabled		
Fast MA to RAS# Delay	: 2 Clks		
System BIOS Cacheable	: Disabled		
Video BIOS Cacheable	: Disabled	ESC : Quit	↑ ↓ → ← : Select Item
8 Bit I/O Recovery Time	: 1	F1 : Help	PU/PD/+/- : Modify
16 Bit I/O Recovery Time	: 2	F5 : Old Values (Shift)	F2 : Color
Memory Hole at 15M-16M	: Disabled	F6 : Load BIOS Defaults	
PCI2.1 Compliance	: Disabled	F7 : Load Setup Defaults	

- **Auto Configuration**
Auto Configuration selects predetermined optimal values of chipset parameters. When disabled, chipset parameters revert to setup information stored in CMOS. Many fields in this screen are not available when Auto Configuration is enabled. The default value is "Disabled".
- **DRAM Timing**
The value in this field depends on performance parameters of the installed memory chips (DRAM). Do not change the value from the factory setting unless you install new memory that has a different performance rating than the original DRAMs. The default value is "60ns".

- **DRAM Leadoff Timing**
Selects the combination of CPU clocks the DRAM on your board requires before each read from or write to the memory. Changing the value from the setting determined by the board designer for the installed DRAM might cause memory errors. The default value is "10/6/3".
- **DRAM Read Burst (EDO/FP)**
Sets the timing for reads from EDO (Extended Data Output) or FPM (Fast Page Mode) memory. The lower the timing numbers, the faster the system addresses memory. Selecting timing numbers lower than the installed DRAM specifications may result in memory errors. The default value is "x222/x333".
- **DRAM Write Burst Timing**
Sets the timing for writes to memory. The lower the timing numbers, the faster the system addresses memory. Selecting timing numbers lower than the installed DRAM specifications may result in memory errors. The default value is "x222".
- **Fast EDO Lead Off**
Set this option to Enabled only when using EDO DRAMs in either a synchronous cache or a cache-less system. It causes a 1-HCLK pull-in for all read leadoff latencies for EDO DRAMs (i.e., page hits, page misses, and row misses). Select Disabled if any of the DRAM rows is populated with FPM DRAMs. The default value is "Disabled".
- **Refresh RAS# Assertion**
This item selects the number of clock ticks RAS# (Row Address Strobe) is asserted for refresh cycles. The default value is "4 Clks".
- **Fast RAS to CAS Delay**
When DRAM is refreshed, both rows and columns are addressed separately. This field lets you insert a timing delay between the CAS and RAS strobe signals used when DRAM is written to, read from, or refreshed. The default value is "3".
- **DRAM Page Idle Timer**
Selects the amount of time in HCLKs that the DRAM controller waits to close a DRAM page after the CPU becomes idle. The default value is "2 Clks".

- **DRAM Enhanced Paging**
When Enabled, the chipset keeps the page open until a page/row miss. When Disabled, the chipset uses additional information to keep the DRAM page open when the host may be "right back." The default value is "Enabled".
- **Fast MA to RAS# Delay CLK**
The values in this field are set by the system board designer, depending on the DRAM installed. Do not change the values in this field unless you change the specifications of installed DRAM or the installed CPU. The default value is "2 Clks".
- **System BIOS Cacheable**
Selecting Enabled allows caching of the system BIOS ROM at F0000h-FFFFFh, resulting in better system performance. However, if any program writes to this memory area, a system error may result. The default value is "Disabled".
- **Video BIOS Cacheable**
Selecting Enabled allows caching of the video BIOS ROM at C0000h to C7FFFh, resulting in better video performance. However, if any program writes to this memory area, a system error may result. The default value is "Disabled".
- **8/16 Bit I/O Recovery Time**
The I/O recovery mechanism adds bus clock cycles between PCI-originated I/O cycles to the ISA bus. This delay takes place because the PCI bus is so much faster than the ISA bus.
These two fields let you add recovery time (in bus clock cycles) for 16-bit and 8-bit I/O. The default values are "1" for 8 Bit I/O Recovery Time and "2" for 16 Bit I/O Recovery Time.
- **Memory Hole at 15M-16M**
You can reserve this area of system memory for ISA adapter ROM. When this area is reserved, it cannot be cached. The user information of peripherals that need to use this area of system memory usually discusses their memory requirements. The default value is "Disabled".
- **PCI 2.1 Compliance**
Concurrent PCI allows multiple PCI transfers from the PCI master buses to memory to CPU. By default, this field is set to **Disabled**.

- **DRAM Refresh Rate**
Selects the period required to refresh the DRAMs, according to DRAM specifications. The default value is "15.6 us".
- **Power Supply Type**
This item allows you identify the type of power supply installed on your system. The default value is "AT".
- **CPU Warning Temperature**
This option lets you set the CPU temperature limit where the system will produce a warning indicating CPU temperature has already exceeded. The default value is "Disabled".
- **Current CPU Temperature**
This is an auto feature of the Award BIOS which displays the actual CPU temperature level inside your system.

7.8 Power Management Setup

The Power Management Setup screen appears like this:

**ROM PCI/ISA BIOS (2A59IA59)
POWER MANAGEMENT SETUP
AWARD SOFTWARE, INC.**

Power Management : Disabled PM Control by APM : Yes Video Off Method : V/H SYNC+Blank Video Off After : Standby Modem Use IRQ : 3 Doze Mode : Disabled Standby Mode : Disabled Suspend Mode : Disabled HDD Power Down : Disabled Throttle Duty Cycle : 62.5% ZZ Active in Suspend : Disabled VGA Active Monitor : Enabled Soft-Off by PWR-BTTN : Instant-Off CPUFAN Off In Suspend : Enabled Resume by Ring : Enabled IRQ8 Break Suspend : Disabled	** Reload Global Timer Events ** IRQ[3-7,9-15],NMI : Enabled Primary IDE 0 : Disabled Primary IDE 1 : Disabled Secondary IDE 0 : Disabled Secondary IDE 1 : Disabled Floppy Disk : Disabled Serial Port : Enabled Parallel Port : Disabled ESC: Quit ↑↓→←: Select Item F1 : Help PU / PD / + / - : Modify F5 : Old Values (Shift)F2 : Color F6 : Load BIOS Defaults F7 : Load Setup Defaults
--	--

- **Power Management**

This option allows you to select the type (or degree) of power saving for Doze, Standby, and Suspend modes. The table below describes each power management mode:

Max Saving	Maximum power savings. Only Available for SL CPUs. Inactivity period is 1 minute in each mode.
User Define	Sets each mode individually. Select time-out periods in the PM Timers section, following.
Min Saving	Minimum power savings. Inactivity period is 1 hour in each mode (except the hard drive).
Disabled	Default value

- **PM Control by APM**

If Advanced Power Management (APM) is installed on your system, selecting Yes gives better power savings. The default value is "Yes".

No	System BIOS will ignore APM when power managing the system
Yes	System BIOS will wait for APM's prompt before it enters any PM mode (i.e., DOZE, STANDBY or SUSPEND). Note: If APM is installed or if there is a task running, even when the timer has timed out, the APM will not prompt the BIOS to put the system into any power saving mode!

NOTE: *If APM is not installed, this option has no effect.*

- **Video Off Method**

Determines the manner in which the monitor is blanked.

V/H SYNC+Blank	Turns OFF vertical and horizontal synchronization ports and writes blanks to the video buffer
DPMS	Select this option if your monitor supports the Display Power Management Signaling (DPMS) standard of the Video Electronics Standards Association (VESA). Use the software supplied for your video subsystem to select video power management values.
Blank Screen	System only writes blanks to the video buffer.

- **Video Off After**

As the system moves from lesser to greater power-saving modes, select the mode in which you want the monitor to blank off. The default value is "Standby".

NA	System BIOS will never turn off the screen
Suspend	Screen off when system is in SUSPEND mode
Standby	Screen off when system is in STANDBY mode
Doze	Screen off when system is in DOZE mode

NOTE: Green monitors detect the V/H SYNC signals to turn off its electron gun

- **Modem Use IRQ**

3, 4, 5, 7, 9, 10, 11, NA	For external modem, 3 or 4 will be used for card type modem. It is up to card definition. Default is 3.
--------------------------------------	---

- **Doze Mode**

After the selected period of system inactivity (1 minute to 1 hour), the CPU clock runs at slower speed while all other devices still operate at full speed. The default value is "Disabled".

Disabled	System will never enter doze mode
1/2/4/6/8/10/20/30/40 Min/1 Hr	Defines the continuous idle time before the system entering DOZE mode.

- **Standby Mode**

After the selected period of system inactivity (1 minute to 1 hour), the fixed disk drive and the video shut off while all other devices still operate at full speed. The default value is "Disabled".

Disabled	System will never enter STANDBY mode
1/2/4/6/8/10/20/30/40 Min/1 Hr	Defines the continuous idle time before the system entering STANDBY mode. If any item defined in (J) is enabled & active, STANDBY timer will be reloaded

- **Suspend Mode**

After the selected period of system inactivity (1 minute to 1 hour), all devices except the CPU shut off. The default value is "Disabled".

Disabled	System will never enter SUSPEND mode
1/2/4/6/8/10/20/30/40 Min/1 Hr	Defines the continuous idle time before the system entering SUSPEND mode. If any item defined in (J) is enabled & active, SUSPEND timer will be reloaded

- **HDD Power Down**

After the selected period of drive inactivity (1 to 15 minutes), the hard disk drive powers down while all other devices remain active. The default value is "Disabled".

Disabled	HDD's motor will not power OFF.
1/2/3/4/5/6/7/8/9/10/ 11/12/13/14/15 Min	Defines the continuous HDD idle time before the HDD enters power saving mode (motor OFF)

- **Throttle Duty Cycle**

When the system enters Doze mode, the CPU clock runs only part of the time. You may select the percent of time that the clock runs. The default value is "62.5%".

- **ZZ Active in Suspend**

When Enabled, the ZZ signal is active during Suspend mode. The default value is "Disabled".

- **VGA Active Monitor**

When Enabled, any video activity restarts the global timer for Standby mode. The default value is "Enabled".

- **Soft-Off by PWR-BTTN**

This option only works with systems using an ATX power supply. It also allows the user to define which type of soft power OFF sequence the system will follow. The default value is "Instant-Off".

Instant-Off	This option follows the conventional manner systems perform when power is turned OFF. Instant-Off is a soft power OFF sequence requiring only the switching of the power supply button to OFF
Delay 4 Sec.	Upon turning OFF system from the power switch, this option will delay the complete system power OFF sequence by approximately 4 seconds. Within this delay period, system will temporarily enter into Suspend Mode enabling you to restart the system at once.

- **CPUFAN Off in Suspend**

When Enabled, the CPU fan turns off during Suspend mode. The default value is "Enabled".

- **Resume by Ring**
This option allows the system to resume or wake up upon detecting any ring signals coming from an installed modem. The default value is "Enabled".
- **IRQ8 Break Suspend**
You can turn on or off monitoring of IRQ8 (the Real Time Clock) so it does not awaken the system from Suspend mode. The default value is "Disabled".
- **Reload Global Timer Events**
When *Enabled*, an event occurring on each device listed below restarts the global time for Standby mode.
- **IRQ3 -7, 9-15, NMI** The default value is "Enabled".
 - Primary IDE 0** The default value is "Disabled".
 - Primary IDE 1** The default value is "Disabled".
 - Secondary IDE 0** The default value is "Disabled".
 - Secondary IDE 1** The default value is "Disabled".
 - Floppy Disk** The default value is "Disabled".
 - Serial Port** The default value is "Disabled".
 - Parallel Port** The default value is "Disabled".

7.9 PnP/PCI Configuration Setup

This section describes configuring the PCI bus system. PCI, or Personal Computer Interconnect, is a system which allows I/O devices to operate at speeds nearing the speed the CPU itself uses when communicating with its own special components. This section covers some very technical items and it is strongly recommended that only experienced users should make any changes to the default settings.

**ROM PCI/ISA BIOS (2A59IA59)
PNP/PCI CONFIGURATION SETUP
AWARD SOFTWARE, INC.**

PNP OS Installed	: No	PCI IDE IRQ Map To	: PCI-AUTO
Resources Controlled By	: Manual	Primary IDE INT#	: A
Reset Configuration Data	: Disabled	Secondary IDE INT#	: B
IRQ-3 assigned to	: PCI/ISA PnP	Used MEM base addr	: N/A
IRQ-4 assigned to	: PCI/ISA PnP	Used Memory Length	: 8K
IRQ-5 assigned to	: PCI/ISA PnP	Assign IRQ For USB	: Enabled
IRQ-7 assigned to	: PCI/ISA PnP		
IRQ-9 assigned to	: PCI/ISA PnP		
IRQ-10 assigned to	: PCI/ISA PnP		
IRQ-11 assigned to	: PCI/ISA PnP		
IRQ-12 assigned to	: PCI/ISA PnP		
IRQ-14 assigned to	: PCI/ISA PnP		
IRQ-15 assigned to	: PCI/ISA PnP		
DMA-0 assigned to	: PCI/ISA PnP		
DMA-1 assigned to	: PCI/ISA PnP	ESC: Quit	↑↓→←: Select Item
DMA-3 assigned to	: PCI/ISA PnP	F1 : Help	PU / PD / + / - : Modify
DMA-5 assigned to	: PCI/ISA PnP	F5 : Old Values	(Shift)F2 : Color
DMA-6 assigned to	: PCI/ISA PnP	F6 : Load BIOS Defaults	
DMA-7 assigned to	: PCI/ISA PnP	F7 : Load Setup Defaults	

- **PNP OS Installed**
Select Yes if the system operating environment is Plug-and-Play aware (e.g., Windows 95). The default value is "No".
- **Resources Controlled By**
The Award Plug and Play BIOS can automatically configure all the boot and Plug and Play-compatible devices. If you select Auto, all the interrupt request (IRQ), DMA assignment, and Used DMA fields disappear, as the BIOS automatically assigns them. The default value is "Manual".

- **Reset Configuration Data**
Normally, you leave this field Disabled. Select Enabled to reset Extended System Configuration Data (ESCD) when you exit Setup if you have installed a new add-on and the system reconfiguration has caused such a serious conflict that the operating system cannot boot. The default value is *“Disabled”*.
- **IRQ n Assigned to**
When resources are controlled manually, assign each system interrupt as one of the following types, depending on the type of device using the interrupt:
 1. Legacy ISA Devices compliant with the original PC AT bus specification, requiring a specific interrupt (such as IRQ4 for serial port 1).
 2. PCI/ISA PnP Devices compliant with the Plug and Play standard, whether designed for PCI or ISA bus architecture. The default values for all IRQ n are *“PCI/ISA PnP”*.
- **DMA n Assigned to**
When resources are controlled manually, assign each system DMA channel as one of the following types, depending on the type of device using the interrupt:
 1. Legacy ISA Devices compliant with the original PC AT bus specification, requiring a specific DMA channel.
 2. PCI/ISA PnP Devices compliant with the Plug and Play standard, whether designed for PCI or ISA bus architecture. The default values for all DMA n are *“PCI/ISA PnP”*.
- **PCI IDE IRQ Map To**
This field lets you select PCI IDE IRQ mapping or PC AT (ISA) interrupts. If your system does not have one or two PCI IDE connectors on the system board, select values according to the type of IDE interface(s) installed in your system (PCI or ISA). Standard ISA interrupts for IDE channels are IRQ14 for primary and IRQ15 for secondary. The default value is *“PCI-AUTO”*.

- **Primary/Secondary IDE INT#**

Each PCI peripheral connection is capable of activating up to four interrupts: INT# A, INT# B, INT# C and INT# D. By default, a PCI connection is assigned INT# A. Assigning INT# B has no meaning unless the peripheral device requires two interrupt services rather than just one. Because the PCI IDE interface in the chipset has two channels, it requires two interrupt services. The primary and secondary IDE INT# fields default to values appropriate for two PCI IDE channels, with the primary PCI IDE channel having a lower interrupt than the secondary. The default values are "A" for Primary IDE INT# and "B" for Secondary IDE INT#.

NOTE: *These options don't appear when the item PCI IDE IRQ Map To is set as "ISA".*

- **Used MEM base addr**

Selects a base address for the memory area used by any peripheral that requires high memory. The default value is "NA".

- **Used MEM Length**

Selects a length for the memory area specified in the previous field. This field does not appear if no base address is specified. The default value is "8K".

NOTE: *This options doesn't appear when the item Used MEM base addr is set as "N/A".*

- **Assign IRQ for USB**

This item allows you to assign IRQ for the USB interface. The default value is "Enabled".

7.10 Integrated Peripherals

**ROM PCI/ISA BIOS (2A59IA59)
INTEGRATED PERIPHERALS
AWARD SOFTWARE, INC.**

IDE HDD Block Mode	:Enabled	Onboard Serial Port 2	:2F8/IRQ3
IDE Primary Master PIO	:Auto	UART Mode Select	:Normal
IDE Primary Slave PIO	:Auto	RxD, TxD Active	:Hi, Lo
IDE Primary Master UDMA	:Auto	IP Transmission delay	:Enabled
IDE Primary Slave UDMA	:Auto	Onboard Parallel Port	:378/IRQ7
IDE Secondary Master PIO	:Auto	Parallel Port Mode	:SPP
IDE Secondary Slave PIO	:Auto	EPP Mode Select	:SPP
IDE Secondary Master UDMA	:Auto		
IDE Secondary Slave UDMA	:Auto	WatchDog Time-Out Setting	:0.5 Sec
On-Chip Primary PCI IDE	:Enabled		
On-Chip Secondary PCI IDE	:Enabled		
Onboard PCI SCSI Chip	:Enabled		
USB Keyboard Support	:Disabled		
POWER ON Function	:Button-Only		
KB POWER ON Password	:Enter	ESC: Quit	↑↓→←: Select Item
Hot Key POWER ON	:Ctrl-F1	F1 : Help	PU / PD / + / - : Modify
KBC input clock	:8 MHz	F5 : Old Values (Shift)	F2 : Color
Onboard FDC Controller	:Enabled	F6 : Load BIOS Defaults	
Onboard Serial Port 1	:3F8/IRQ4	F7 : Load Setup Defaults	

The four items related to the WDT describe the set up of the Watchdog Timer (WDT), please refer to the Appendix for details.

- **IDE HDD Block Mode**

Block mode is also called block transfer, multiple commands, or multiple sector read/write. If your IDE hard drive supports block mode (most new drives do), select Enabled for automatic detection of the optimal number of block read/writes per sector the drive can support. The default value is "Enabled".

- **IDE Primary/Secondary Master/Slave PIO**

The four IDE PIO (Programmed Input/Output) fields let you set a PIO mode (0-4) for each of the four IDE devices that the onboard IDE interface supports. Modes 0 through 4 provide successively increased performance. In Auto mode, the system automatically determines the best mode for each device. The default value is "Auto".

- **IDE Primary/Secondary Master/Slave UDMA**
Ultra DMA/33 implementation is possible only if your IDE hard drive supports it and the operating environment includes a DMA driver (Windows 95 OSR2 or a third-party IDE bus master driver). If your hard drive and your system software both support Ultra DMA/33, select Auto to enable BIOS support. The default value is "Auto".
- **On-Chip Primary/Secondary PCI IDE**
The integrated peripheral controller contains an IDE interface with support for two IDE channels. Select Enabled to activate each channel separately. The default value is "Enabled".
NOTE: *Choosing Disabled for these options will automatically remove the IDE Primary Master/Slave PIO and/or IDE Secondary Master/Slave PIO items on the menu.*
- **USB Keyboard Support**
Select Enabled if your system contains a USB controller and you have a USB keyboard. The default value is "Disabled".
- **POWER ON Function**
This option allows users to select the type of power ON sequence for the system to follow. The default value is "Button-Only".

BUTTON-ONLY	Follows the conventional way of turning OFF system power (via power button).
Password	Upon selecting this option, the KB POWER ON Password line appears. Press <Enter> and you'll be prompted to enter and confirm a password of your choice. After setting the password, succeeding attempts to power ON the system will result to null. For system to activate, user must input the password via keyboard then press <Enter>.
Hot KEY	This option is very similar with that of Password. Hot-key combinations range from Ctrl-F1 to Ctrl-F12. User may define this combination from the Hot key Power ON option.
Mouse Left	This allows system to POWER ON by clicking the left mouse button. To enable, user must reboot and allow system to finish booting up otherwise the setting will not take effect.
Mouse Right	This allows system to POWER ON by clicking the right mouse button. To enable this setting, user must reboot and allow system to finish the boot up process otherwise the setting will not take effect.

- **KBC input clock**
This item sets the input clock for the keyboard controller. The default value is "8 MHz".
- **Onboard FDC Controller**
Select Enabled if your system has a floppy disk controller (FDC) installed on the system board and you wish to use it. If you install an add-in FDC or the system has no floppy drive, select Disabled in this field. The default value is "Enabled".
- **Onboard Serial port 1/2**
Select an address and corresponding interrupt for the first and second serial ports. The default values are "3F8/IRQ4" for Onboard Serial Port 1 and "2F8/IRQ3" for Onboard Serial Port 2.
- **UART Mode Select**
The second serial port offers these infrared interface modes:
 1. IrDA
 2. ASKIR IrDA-compliant serial infrared port
 3. Normal (default value)

NOTE: *The UART Mode Select will not appear on the menu once you disable the setting of Onboard Serial Port 2.*

When UART Mode Select is set as ASKIR or IrDA, the options RxD, TxD Active and IR Transmission delay will appear.

- **RxD, TxD Active**
Consult your IR peripheral documentation to select the correct setting of the TxD and RxD signals. The default value is "Hi,Lo".
- **IR Transmission delay**
Full-duplex mode permits simultaneous two-direction transmission. Half-duplex mode permits transmission in one direction only at a time. If no infrared port is present in the system, select Disabled. The default value is "Enabled".
- **Onboard Parallel Port**
Select a logical LPT port name and matching address for the physical parallel (printer) port. The default value is "378/IRQ7".

NOTE: *Choosing Disabled for this option will remove the Parallel Port Mode option on the menu.*

- **Parallel Port Mode**

Select an operating mode for the onboard parallel (printer) port. Select Normal unless your hardware and software require one of the other modes offered in this field. The default value is "SPP".

NOTE: *Selecting EPP on this option will allow selection to the EPP Mode (EPP1.7, EPP1.9)
ECP mode selection will provide option for ECP Mode Use DMA.
Choosing ECP+EPP modes will provide selections for both EPP Mode Select and ECP Mode Use DMA.*

- **EPP Mode Select**

Select EPP port type 1.7 or 1.9.

- **ECP Mode Use DMA**

Select a DMA channel for the port.

- **WatchDog Time-Out Setting**

The default value is "0.5 Sec".

7.11 Supervisor/User Password Setting

You can set either supervisor or user password, or both of them. The differences between are:

1. **supervisor password:** can enter and change the options of the setup menus.
2. **user password:** just can enter but do not have the right to change the options of the setup menus.

When you select this function, the following message will appear at the center of the screen to assist you in creating a password.

ENTER PASSWORD:

Type the password with eight characters at most, and press <Enter>. The password typed will now clear any previously entered password from CMOS memory. You will be asked to confirm the password. Type the password again and press <Enter>. You may also press <Esc> to abort the selection and not enter a password.

To disable password, just press <Enter> when you are prompted to enter password. A message will confirm the password being disabled. Once the password is disabled, the system will boot and you can enter Setup freely.

PASSWORD DISABLED.

When a password is enabled, you have to type it every time you enter Setup. This prevents any unauthorized person from changing your system configuration.

Additionally when a password is enabled, you can also require the BIOS to request a password every time the system reboots. This would prevent unauthorized use of your computer.

You determine when the password is required within the BIOS Features Setup Menu and its Security option. If the Security option is set to "System", the password is required during boot up and entry into Setup. If set as "Setup", prompting will only occur prior to entering Setup.

7.12 IDE HDD Auto Detection

The Enhance IDE feature is included in all Award BIOS. The following is a brief description of this feature.

1. Setup Changes

<I> Auto-detection

BIOS setup will display all possible modes supported by the HDD including NORMAL, LBA & LARGE.

If HDD does not support LBA modes, no 'LBA' option will be shown.

Users can select a mode appropriate for them.

**ROM/PCI/ISA BOPS (2XXXXXXX)
CMOS SETUP UTILITY
AWARD SOFTWARE, INC.**

HARD DISKS	TYPE	SIZE	CYLS	HEAD	PRECOMP	LANDZ	SECTOR	MODE
Primary Master :								
Select Primary Master Option (N = Skip) : N								
OPTION	SIZE	CYLS	HEADS	PRECOMP	LANDZONE	SECTORS	MODE	
1 (Y)	516	1120	16	65535	1119	59	NORMAL	
2	516	524	32	0	1119	63	LBA	
3	516	560	32	65535	1119	59	LARGE	

<II> Standard CMOS Setup

	CYLS	Heads	Precomp	Landzone	Sector	Mode
Primary Master :User(516MB)	1120	16	65535	1119	59	NORMAL
Primary Slave :None (203MB)	684	16	65535	685	38	-----
Secondary Master :	None	0	0	0	0	0 0
Secondary Slave :	None	0	0	0	0	0 0

When HDD type is in 'user' type, the "MODE" option will be open for user to select HDD mode.

2. HDD Modes

The Award BIOS supports 3 HDD modes : NORMAL, LBA & LARGE

■ NORMAL mode

Generic access mode in which neither the BIOS nor the IDE controller will make any transformations during accessing.

The maximum number of cylinders, head & sectors for NORMAL mode are 1024, 16 & 63.

	no. Cylinder	(1024)
x	no. Head	(16)
x	no. Sector	(63)
x	no. per sector	(512)
<hr/>		
528 Megabytes		

If user sets his HDD to NORMAL mode, the maximum accessible HDD size will be 528MB even though its physical size may be greater than that!

■ LBA (Logical Block Addressing) mode

A new HDD accessing method to overcome the 528MB bottleneck. The number of cylinders, heads & sectors shown in setup may not be the number physically contained in the HDD.

During HDD accessing, the IDE controller will transform the logical address described by sector, head & cylinder number into its own physical address inside the HDD.

The maximum HDD size supported by LBA mode is 8.4GB which is obtained by the following formula:

	no. Cylinder	(1024)
x	no. Head	(255)
x	no. Sector	(63)
x	bytes per sector	(512)
<hr/>		
814 Gigabytes		

■ LARGE mode

Extended HDD access mode supported by Award Software.

Some IDE HDDs contain more than 1024 cylinder without LBA support (in some cases, user does not want LBA). The Award BIOS provides another alternative to support these kinds of HDD!

Example of LARGE mode:

<u>CYLS</u>	<u>HEADS</u>	<u>SECTOR</u>	<u>MODE</u>
1120	16	59	NORMAL
560	32	59	LARGE

BIOS tricks DOS (or other OS) that the number of cylinders is less than 1024 by dividing it by 2. At the same time, the number of heads is multiplied by 2. A reverse transformation process will be made inside INT13h in order to access the right HDD address!

Maximum HDD size:

	no. Cylinder	(1024)
x	no. Head	(32)
x	no. Sector	(63)
x	bytes per sector	(512)
		<hr/>
		1 Gigabytes

3. Remarks

To support LBA or LARGE mode of HDDs, there must be some software involved. All these software are located in the Award HDD Service Routine (INT 13h). It may fail to access a HDD with LBA (LARGE) mode selected if you are running under a Operating System that replaces the whole INT 13h.

7.13 Hard Disk Low Level Format Utility

This Award Low-Level-Format Utility is designed as a tool to save your time formatting your hard disk. The utility automatically looks for the necessary information of the drive you selected. This utility also searches for bad tracks and lists them for your reference.

Shown below is the Main Menu after you enter into the Award Low-Level-Format Utility.

Hard Disk Low Level Format Utility				BAD TRACKS TABLE			
				NO.	CYLS	HEAD	
SELECT DRIVE BAD TRACK LIST PREFORMAT							
Current select drive is : C							
DRIVE: C CYLINDER : 0 HEAD: 0							
	Size	CYLS	Head	Precomp	Landz	Sector	Mode
Primary Master:	0	0	0	0	0	0	AUTO
Primary Slave:	0	0	0	0	0	0	AUTO
Up/Down - Select item		Enter - Accept		ESC-Exit/Abort			
Copyright © Award Software, Inc. 1992-94 All Rights Reserved							

- **Control Keys**
Use the Up and Down arrow keys to move around the selections displayed on the upper screen. Press <Enter> to accept the selection. Press <Esc> to abort the selection or exit the utility.
- **Select Drive**
Select from installed hard disk drive C or D. Listed at the bottom of the screen is the drive automatically detected by the utility.
- **Bad Track List**
 - **Auto scan bad track**
The utility will automatically scan bad tracks and list the bad tracks on the window at the right side of the screen.
 - **Add bad track**
Directly type in the information of the known bad tracks on the window at the right side of the screen.

- **Modify bad track**
Modify the information of the added bad tracks in the window at the right side of the screen.
- **Delete bad track**
Delete the added bad tracks on the window at the right side of the screen.
- **Clear bad track table**
Clear the whole bad track list on the window at the right side of the screen.
- **Preformat**
 - **Interleave**
Select the interleave number of the hard disk drive you wish to perform low level format. You may select from 1 to 8. Check the documentation that came with the drive for the correct interleave number, or select 0 for utility automatic detection.
 - **Auto scan bad track**
This allows the utility to scan first then format by each track.
 - **Start**
Press <Y> to start low level format.

7.14 Power-On Boot

After you have made all the changes to CMOS values and the system cannot boot with the CMOS values selected in Setup, restart the system by turning it OFF then ON or press the "RESET" button on the system case. You may also restart by simultaneously pressing the <Ctrl>, <Alt>, and <Delete> keys. Upon restarting the system, immediately press <Insert> to load the BIOS default CMOS values for boot up.

A p p e n d i x A

Watchdog Timer

Using the Watchdog Function

Follow these steps when using the watchdog function onboard the **SBC8155** CPU card.

1. To enable the watchdog function, read I/O port 121H (e.g., "1 121") under "debug" of MS-DOS environment. To disable the function, place I/O port 120H under "debug" of MS-DOS environment.

Reset Watchdog -Read I/O Port 121H
Disable Watchdog - Read I/O Port 120H

In system Run_Time, you still have to read I/O Port 121H to reset the Watchdog timer.

If the system fails, the TSR should be stopped for the Watchdog Reset to be activated.

2. Set the corresponding Watchdog option in the Integrated Peripherals menu of the CMOS Setup utility. The available Time-out Trigger options are 0.5, 1, 5, 10, 20, 50, 100, 150, 200, 250, 300, 350, 400, 450, 500 and 1000 sec(s).

This page does not contain any information.

Appendix B

Connector Pin Assignments

40-pin IDE Interface Connector: CN4 and CN5

Pin	Description	Pin	Description	Pin	Description
1	Reset #	2	GND	3	Data 7
4	Data 8	5	Data 6	6	Data 9
7	Data 5	8	Data 10	9	Data 4
10	Data 11	11	Data 3	12	Data 12
13	Data 2	14	Data 13	15	Data 1
16	Data 14	17	Data 0	18	Data 16
19	GND	20	No connector	21	No connector
22	GND	23	IOW #	24	GND
25	IOR #	26	GND	27	IOCHRDY
28	No connector	29	No connector	30	GND-Default
31	Interrupt	32	No connector	33	SA1
34	No connector	35	SA0	36	SA2
37	HDC CS0 #	38	HDC CSI #	39	HDD Active #
40	GND				

CRT/VGA Connector: CN13

Pin	Description
1	Red
2	Green
3	Blue
4	No connector
5	GND
6	GND
7	GND
8	GND
9	No connector
10	GND
11	No connector
12	No connector
13	Hsync
14	Vsync
15	No connector

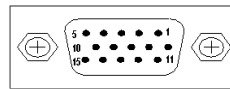

Standard 15-pin pin header connector for CRT VGA display

Floppy Disk Connector: CN6

Pin	Description	Pin	Description	Pin	Description
1	GND	2	Reduce write current	3	GND
4	No connector	5	GND	6	No connector
7	GND	8	Index#	9	GND
10	Motor enable A#	11	GND	12	Drive select B#
13	GND	14	Drive select A#	15	GND
16	Motor enable B#	17	GND	18	Direction#
19	GND	20	STEP#	21	GND
22	Write data#	23	GND	24	Write gate#
25	GND	26	Track 0 #	27	GND
28	Write protect#	29	GND	30	Read data#
31	GND	32	Side 1 select#	33	GND
34	Disk change#				

Parallel Port Connector: CN7

Pin	Description	Pin	Description
1	Strobe#	14	Auto Form Feed#
2	Data 0	15	Error#
3	Data 1	16	Initialize#
4	Data 2	17	Printer Select In#
5	Data 3	18	GND
6	Data 4	19	GND
7	Data 5	20	GND
8	Data 6	21	GND
9	Data 7	22	GND
10	Acknowledge#	23	GND
11	Busy	24	GND
12	Paper Empty#	25	GND
13	Printer Select	26	

RS-232 pin assignments for COM1 (CN12)

Pin	Description	Pin	Description
1	Data Carrier Detect (DCD)	2	Data Set Ready (DSR)
3	Receive Data (RXD)	4	Request to Send (RTS)
5	Transmit Data (DRT)	6	Clear to Send (CTS)
7	Data Terminal Ready (DTR)	8	Ring Indicator (RI)
9	Ground (GND)		

RS-232/422/485 pin assignments for COM1 & COM2 (CN8, CN9)

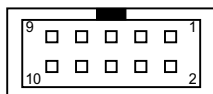

CN12

Pin #	Signal Name		
	RS-232	R2-422	RS-485
1	DCD	TX-	DATA-
2	DSR	No connector	No connector
3	RX	TX+	DATA+
4	RTS	No connector	No connector
5	TX	RX+	No connector
6	CTS	No connector	No connector
7	DTR	RX	No connector
8	RI	No connector	No connector
9	GND	GND	GND
10	No connector	No connector	No connector

External Keyboard Connector: CN15

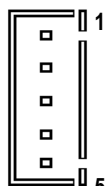

CN15

Pin #	Signal Name
1	Keyboard clock
2	Keyboard data
3	PG
4	GND
5	Keyboard Vcc

PS/2 Mouse Connector: CN16

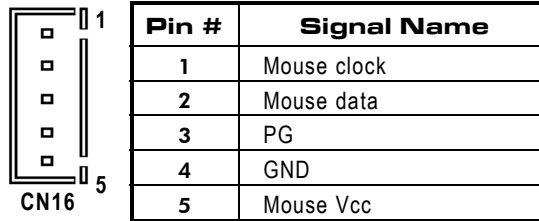

USB Connector: CN10

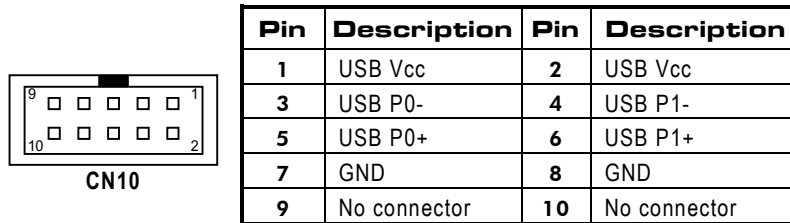

Ethernet Connector: CN11 (SBC8155VES & SBC8155VE only)

Pin	Description	Pin	Description
1	Tx+ (Data transmission positive)	2	Tx- (Data reception negative)
3	Rx+(Data reception positive)	4	No connector
5	No connector	6	Rx- (Data reception negative)
7	No connector	8	No connector

General Output Connector: CN1

Reset Switch: Pins 17 & 18
HDD Active LED: Pins 19 & 20
Speaker: Pins 2, 4, 6, & 8
SMI Switch: Pins 11 & 12
KeyLock/Power LED: Pins 1, 3, 5, 7 & 9

Pin	Description	Pin	Description
1	Vcc	2	Ext. Speaker
3	No connector	4	Int. Buzzer
5	GND	6	GND
7	Keylock	8	Vcc
9	GND	10	No connector
11	GND	12	SMI
13	No connector	14	No connector
15	Reserved	16	Reserved
17	GND	18	RESET
19	HD_LED	20	Vcc

IrDA Connector: CN17

Pin	Signal	Pin	Signal
1	Vcc	2	No connector
3	No connector	4	Reserved
5	RX	6	Reserved
7	GND	8	No connector
9	Tx	10	No connector

You must also configure the setting on the “UART Mode Select” from the Integrated Peripherals menu your BIOS utility program to select whether UART2 is directed for use with COM2, IrDA, or other IrDA-compliant serial infrared port. Use the five pins of **CN17** and connect a ribbon cable from the module to the motherboard according to the pin definitions.

2-pin CPU Fan Connector: CN20

Pin	Description
1	+12V
2	GND

PICMG Slot Connector

Signal	Pin	Pin	Signal
GND	B01	A01	IOCHCHK#
RESETDRV	B02	A02	SD7
+5V	B03	A03	SD6
IRQ9	B04	A04	SD5
-5V	B05	A05	SD4
DRQ2	B06	A06	SD3
-12V	B07	A07	SD2
ENDXFR#	B08	A08	SD1
+12V	B09	A09	SD0
SMEMW#	B11	A11	AEN
SMEMR#	B12	A12	SA19
GND	B10	A10	IOCHRDY
IOW#	B13	A13	SA18
IOR#	B14	A14	SA17
DACK3#	B15	A15	SA16
DRQ3	B16	A16	SA15
DACK1#	B17	A17	SA14
DRQ1	B18	A18	SA13
REFRSH#	B19	A19	SA12
SYSCLK	B20	A20	SA11
IRQ7	B21	A21	SA10
IRQ6	B22	A22	SA9
IRQ5	B23	A23	SA8
IRQ4	B24	A24	SA7
IRQ3	B25	A25	SA6
DACK2#	B26	A26	SA5

Continued

Signal	Pin	Pin	Signal
TC	B27	A27	SA4
BALE	B28	A28	SA3
+5V	B29	A29	SA2
OSC	B30	A30	SA1
GND	B31	A31	SA0
Connector Key			
Connector Key			
Connector Key			
MEMCS16#	D01	C01	SBHE#
IOCS16#	D02	C02	LA23
IRQ10	D03	C03	LA22
IRQ11	D04	C04	LA21
IRQ12	D05	C05	LA20
IRQ15	D06	C06	LA19
IRQ14	D07	C07	LA18
DACK0#	D08	C08	LA17
DRQ0	D09	C09	MEMR#
DACK5#	D10	C10	MEMW#
DRQ5	D11	C11	SD8
DACK6#	D12	C12	SD9
DRQ6	D13	C13	SD10
DACK7#	D14	C14	SD11
DRQ7	D15	C15	SD12
+5V	D16	C16	SD13
MASTER#	D17	C17	SD14
GND	D18	C18	SD15
-12V	F01	E01	TRST#
TCK	F02	E02	+12V
GND	F03	E03	TMS
TDO	F04	E04	TDI
+5V	F05	E05	+5V
+5V	F06	E06	INTA#
INTB#	F07	E07	INTC#

Continued

Signal	Pin	Pin	Signal
INTD#	F08	E08	+5v
REQ3#	F09	E09	CLKC
REQ1#	F10	E10	+5V (I/O)
GNT3#	F11	E11	CLKD
GND	F12	E12	GND
GND	F13	E13	GND
CLKA	F14	E14	GNT1#
GND	F15	E15	RST#
CLKB	F16	E16	+5V (I/O)
GND	F17	E17	GNT0#
REQ0#	F18	E18	GND
+5V (I/O)	F19	E19	REQ2#
AD31	F20	E20	AD30
AD29	F21	E21	+3.3V
GND	F22	E22	AD28
AD27	F23	E23	SD26
AD25	F24	E24	GND
+3.3V	F25	E25	AD24
C/BE3#	F26	E26	GNT2#
AD23	F27	E27	+3.3V
GND	F28	E28	AD22
AD21	F29	E29	AD20
AD19	F30	E30	GND
+3.3V	F31	E31	AD18
AD17	F32	E32	AD16
C/BE2#	F33	E33	+3.3V
GND	F34	E34	FRAME#
IRDY#	F35	E35	GND
+3.3V	F36	E36	TRDY#
DEVSEL#	F37	E37	GND
GND	F38	E38	STOP#
LOCK#	F39	E39	+3.3V
PERR#	F40	E40	SDONE

Continued

Signal	Pin	Pin	Signal
+3.3V	F41	E41	SB0#
SERR#	F42	E42	GND
+3.3V	F43	E43	PAR
C/BE1#	F44	E44	AD15
AD14	F45	E45	+3.3V
GND	F46	E46	AD13
AD12	F47	E47	AD11
AD10	F48	E48	GND
GND	F49	E49	AD09
Connector Key			
Connector Key			
AD08	F52	E52	C/BE0#
AD07	F53	E53	+3.3V
+3.3V	F54	E54	AD06
AD05	F55	E55	AD04
AD03	F56	E56	GND
GND	F57	E57	AD02
AD01	F58	E58	AD00
+5V (I/O)	F59	E59	+5V (I/O)
ACK64#	F60	E60	REQ64#
+5V	F61	E61	+5V
+5V	F62	E62	+5V
Connector Key			
Connector Key			

This page does not contain any information.

A p p e n d i x C

Award BIOS Reference

POST Messages

During the Power On Self Test (POST), the BIOS automatically detects for errors and will either display a message on the screen requiring you to fix such problem or produce a beep code. Once a message is displayed, the following line will succeed it:

PRESS F1 TO CONTINUE, CTRL-ALT-ESC OR DEL TO ENTER SETUP

POST Beep

Currently there is only one beep code in the Award BIOS. This code indicates that a video error has occurred and the BIOS cannot initialize the video screen to display any additional information. This beep code consists of a single long beep followed by two short beeps.

Error Messages

One or more of the following messages may be displayed if the BIOS detects an error during the POST. This list includes messages for both the ISA and the EISA BIOS.

CMOS BATTERY HAS FAILED	CMOS battery is no longer functional. It should be replaced.
CMOS CHECKSUM ERROR	Checksum of CMOS is incorrect. This can indicate that CMOS has become corrupt. A weak battery may have caused this error. Check the battery and replace if necessary.

Continued

DISK BOOT FAILURE, INSERT SYSTEM DISK AND PRESS ENTER	No boot device was found. This could mean that either a boot drive was not detected or the drive does not contain proper system boot files. Insert a system disk into Drive A: and press <Enter>. If you assumed the system would boot from the hard drive, make sure the controller is inserted correctly and all cables are properly attached. Also be sure the disk is formatted as a boot device. Then reboot the system.
DISKETTE DRIVES OR TYPES MISMATCH ERROR - RUN SETUP	Type of diskette drive installed in the system is different from the CMOS definition. Run Setup to reconfigure the drive type correctly.
DISPLAY SWITCH IS SET INCORRECTLY	Display switch on the motherboard can be set to either monochrome or color. This indicates the switch is set to a different setting than indicated in Setup. Determine which setting is correct, and then either turn off the system and change the jumper, or enter Setup and change the VIDEO selection.
DISPLAY TYPE HAS CHANGED SINCE LAST BOOT	Since last powering off the system, the display adapter has been changed. You must configure the system for the new display type.
EISA Configuration Checksum Error PLEASE RUN EISA CONFIGURATION UTILITY	The EISA non-volatile RAM checksum is incorrect or cannot correctly read the EISA slot. This can indicate either the EISA non-volatile memory has become corrupt or the slot has been configured incorrectly. Also be sure the card is installed firmly in the slot.

Continued

EISA Configuration Is Not Complete PLEASE RUN EISA CONFIGURATION UTILITY	<p>The slot configuration information stored in the EISA non-volatile memory is incomplete.</p> <p>NOTE: When either of these errors appear, the system will boot in ISA mode, which allows you to run the EISA Configuration Utility.</p>
ERROR ENCOUNTERED INITIALIZING HARD DRIVE	<p>Hard drive cannot be initialized. Be sure the adapter is installed correctly and all cables are correctly and firmly attached. Also be sure the correct hard drive type is selected in Setup.</p>
ERROR INITIALIZING HARD DISK CONTROLLER	<p>Cannot initialize controller. Make sure the cord is correctly and firmly installed in the bus. Be sure the correct hard drive type is selected in Setup. Also check to see if any jumper needs to be set correctly on the hard drive.</p>
FLOPPY DISK CNTRLR ERROR OR NO CNTRLR PRESENT	<p>Cannot find or initialize the floppy drive controller. make sure the controller is installed correctly and firmly. If there are no floppy drives installed, be sure the Diskette Drive selection in Setup is set to NONE.</p>
Invalid EISA Configuration PLEASE RUN EISA CONFIGURATION UTILITY	<p>The non-volatile memory containing EISA configuration information was programmed incorrectly or has become corrupt. Re-run EISA configuration utility to correctly program the memory.</p> <p>NOTE: When this error appears, the system will boot in ISA mode, which allows you to run the EISA Configuration Utility.</p>

Continued

KEYBOARD ERROR OR NO KEYBOARD PRESENT	<p>Cannot initialize the keyboard. Make sure the keyboard is attached correctly and no keys are being pressed during the boot.</p> <p>If you are purposely configuring the system without a keyboard, set the error halt condition in Setup to HALT ON ALL, BUT KEYBOARD. This will cause the BIOS to ignore the missing keyboard and continue the boot.</p>
Memory Address Error at ...	<p>Indicates a memory address error at a specific location. You can use this location along with the memory map for your system to find and replace the bad memory chips.</p>
Memory Parity Error at ...	<p>Indicates a memory parity error at a specific location. You can use this location along with the memory map for your system to find and replace the bad memory chips.</p>
MEMORY SIZE HAS CHANGED SINCE LAST BOOT	<p>Memory has been added or removed since the last boot. In EISA mode use Configuration Utility to reconfigure the memory configuration. In ISA mode enter Setup and enter the new memory size in the memory fields.</p>
Memory Verify Error at ...	<p>Indicates an error verifying a value already written to memory. Use the location along with your system's memory map to locate the bad chip.</p>
OFFENDING ADDRESS NOT FOUND	<p>This message is used in conjunction with the I/O CHANNEL CHECK and RAM PARITY ERROR messages when the segment that has caused the problem cannot be isolated.</p>

Continued

OFFENDING SEGMENT:	This message is used in conjunction with the I/O CHANNEL CHECK and RAM PARITY ERROR messages when the segment that has caused the problem has been isolated.
PRESS A KEY TO REBOOT	This will be displayed at the bottom screen when an error occurs that requires you to reboot. Press any key and the system will reboot.
PRESS F1 TO DISABLE NMI, F2 TO REBOOT	When BIOS detects a Non-maskable Interrupt condition during boot, this will allow you to disable the NMI and continue to boot, or you can reboot the system with the NMI enabled.
RAM PARITY ERROR - CHECKING FOR SEGMENT ...	Indicates a parity error in Random Access Memory.
Should Be Empty But EISA Board Found PLEASE RUN EISA CONFIGURATION UTILITY	A valid board ID was found in a slot that was configured as having no board ID. NOTE: When this error appears, the system will boot in ISA mode, which allows you to run the EISA Configuration Utility.
Should Have EISA Board But Not Found PLEASE RUN EISA CONFIGURATION UTILITY	The board installed is not responding to the ID request, or no board ID has been found in the indicated slot. NOTE: When this error appears, the system will boot in ISA mode, which allows you to run the EISA Configuration Utility.
Slot Not Empty	Indicates that a slot designated as empty by the EISA Configuration Utility actually contains a board. NOTE: When this error appears, the system will boot in ISA mode, which allows you to run the EISA Configuration Utility.

Continued

SYSTEM HALTED, (CTRL-ALT-DEL) TO REBOOT ... Indicates the present boot attempt has been aborted and the system must be rebooted. Press and hold down the CTRL and ALT keys and press DEL.

Wrong Board In Slot PLEASE RUN EISA CONFIGURATION UTILITY The board ID does not match the ID stored in the EISA non-volatile memory.
NOTE: When this error appears, the system will boot in ISA mode, which allows you to run the EISA Configuration Utility.

POST Codes

NOTE: *EISA POST codes are typically output to port address 300h. ISA POST codes are output to port address 80h.*

POST (hex)	Description
C0	<ol style="list-style-type: none"> 1. Turn off OEM specific cache, shadow... 2. Initialize all the standard devices with default values standard devices includes: -DMA controller (8237) -Programmable Interrupt Controller (8259) -Programmable Interval Timer (8254) -RTC chip
C1	Auto-detection of onboard DRAM & Cache
C3	<ol style="list-style-type: none"> 1. Test system BIOS checksum 2. Test the first 256K DRAM 3. Expand the compressed codes into temporary DRAM area including the compressed System BIOS & Option ROMs
C5	Copy the BIOS from ROM into E0000-FFFFFF shadow RAM so that POST will go faster
01-02	Reserved
03	Initialize EISA registers (EISA BIOS only)
04	Reserved

Continued

POST (hex)	Description
05	1. Keyboard Controller Self-Test 2. Enable Keyboard Interface
06	Reserved
07	Verifies the basic R/W functionality of CMOS
BE	Program defaults values into chipset according to the MODBINable Chipset Default Table
09	1. Program the configuration register of Cyrix CPU according to the MODBINable Cyrix Register Table 2. OEM specific cache initialization (if needed)
0A	1. Initialize the first 32 interrupt vectors with corresponding Interrupt handlers 2. Initialize INT no from 33-120 with Dummy(Spurious) Interrupt Handler 3. Issue CUID instruction to identify CPU type 4. Early Power Management initialization (OEM specific)

● **This POST code is for boot block**

POST (hex)	Description
C0	1. Turn off OEM specific cache, shadow. 2. Initialize all the standard devices with default values standard devices includes: -DMA controller (8237) -Programmable Interrupt Controller (8259) -Programmable Interval Timer (8254) -RTC chip
C1	Auto-detection of onboard DRAM & Cache
C3	Checking checksum of compressed code
C5	Copy the BIOS from ROM into E0000-FFFFFF shadow RAM so that POST will go faster
01	Clear base memory 0~640K
0C	Initial interrupt vector 00-1FH
0D	Initial ISA VGA
41H	Enable FDD and detect media type
FFH	Boot from FDD

● **This page is for Non-Compressed Version only.**

POST (hex)	Description
01-02	Reserved
C0	Turn off OEM specific cache, shadow...
03	1. Initialize EISA registers (EISA BIOS only) 2. Initialize all the standard devices with default values Standard devices includes: -DMA controller (8237) -Programmable Interrupt Controller (8259) -Programmable Interval Timer (8254) -RTC chip
04	Reserved
05	1. Keyboard Controller Self-Test 2. Enable Keyboard Interface
06	Reserved
07	Verifies the basic R/W functionality of CMOS
BE	Program defaults values into chipset according to the MODBINable Chipset Default Table
C1	Auto-detection of onboard DRAM & Cache
C5	Copy the BIOS from ROM into E0000-FFFFFF shadow RAM so that POST will go faster
08	Test the first 256K DRAM
09	1. Program the configuration register of Cyrix CPU according to the MODBINable Cyrix Register Table 2. OEM specific cache initialization (if needed)
0A	1. Initialize the first 32 interrupt vectors with corresponding Interrupt handlers Initialize INT no from 33-120 with Dummy(Spurious) Interrupt Handler 2. Issue CPUID instruction to identify CPU type 3. Early Power Management initialization (OEM specific)

● **The following POST Codes are for all of Compress Version & Non-Compress Version**

POST (hex)	Description
0B	<ol style="list-style-type: none"> 1. Verify if the RTC time is valid or not 2. Detect bad battery 3. Read CMOS data into BIOS stack area 4. PnP initializations including (PnP BIOS only) <ul style="list-style-type: none"> -Assign CSN to PnP ISA card -Create resource map from ESCD 5. Assign IO & Memory for PCI devices (PCI BIOS only)
0C	Initialization of the BIOS Data Area (40 : 00 – 40:FF)
0D	<ol style="list-style-type: none"> 1. Program some of the Chipset's value according to Setup. (Early Setup Value Program) 2. Measure CPU speed for display & decide the system clock speed 3. Video initialization including Monochrome, CGA, EGA/VGA. If no display device found, the speaker will beep which consists of one single long beep followed by two short beeps.
0E	<ol style="list-style-type: none"> 1. Initialize the APIC (Multi-Processor BIOS only) 2. Test video RAM (If Monochrome display device found) 3. Show messages including: <ul style="list-style-type: none"> - Award Logo, Copyright string, BIOS Date code & Part No. - OEM specific sign on messages - Energy Star Logo (Green BIOS ONLY) - CPU brand, type & speed - Test system BIOS checksum(Non-Compress Version only)
0F	DMA channel 0 test
10	DMA channel 1 test
11	DMA page registers test
12-13	Reserved
14	Test 8254 Timer 0 Counter 2.
15	Test 8259 interrupt mask bits for channel 1
16	Test 8259 interrupt mask bits for channel 2
17	Reserved

Continued

POST (hex)	Description
19	Test 8259 functionality
1A-1D	Reserved
1E	If EISA NVM checksum is good, execute EISA initialization (EISA BIOS only)
1F-29	Reserved
30	Detect Base Memory & Extended Memory Size
31	1. Test Base Memory from 256K to 640K 2. Test Extended Memory from 1M to the top of memory
32	1. Display the Award Plug & Play BIOS Extension message (PnP BIOS only) 2. Program all onboard super I/O chips (if any) including COM ports, LPT ports, FDD port... according to setup value
33-3B	Reserved
3C	Set flag to allow users to enter CMOS Setup Utility
3D	1. Initialize Keyboard 2. Install PS2 mouse
3E	Try to turn on Level 2 cache NOTE: Some chipset may need to turn on the L2 cache in this stage. But usually, the cache is turn on later in POST 61h
3E	Try to turn on Level 2 cache NOTE: Some chipset may need to turn on the L2 cache in this stage. But usually, the cache is turn on later in POST 61h
BF	1. Program the rest of the Chipset's value according to Setup. (Later Setup Value Program) 2. If auto-configuration is enabled, programmed the chipset with pre-defined values in the MODBINable Auto-Table
41	Initialize floppy disk drive controller
42	Initialize Hard drive controller
43	If it is a PnP BIOS, initialize serial & parallel ports
44	Reserved
45	Initialize math coprocessor.

Continued

POST (hex)	Description
46-4D	Reserved
4E	If there is any error detected (such as video, kb...), show all the error messages on the screen & wait for user to press <F1> key
4F	1. If password is needed, ask for password 2. Clear the Energy Star Logo (Green BIOS only)
50	Write all CMOS values currently in the BIOS stack area back into the CMOS
51	Reserved
52	1. Initialize all ISA ROMs 2. Later PCI initializations (PCI BIOS only) -assign IRQ to PCI devices -initialize all PCI ROMs 3. PnP Initializations (PnP BIOS only) -assign IO, Memory, IRQ & DMA to PnP ISA devices -initialize all PnP ISA ROMs 4. Program shadows RAM according to Setup settings 5. Program parity according to Setup setting 6. Power Management Initialization -Enable/Disable global PM -APM interface initialization
53	1. If it is NOT a PnP BIOS, initialize serial & parallel ports 2. Initialize time value in BIOS data area by translate the RTC time value into a timer tick value
60	Setup Virus Protection (Boot Sector Protection) functionality according to Setup setting

This page does not contain any information.