

Introduction

A. Specifications

System Chipset	Intel 82430 TX chipset.
CPU	One 321-pin socket 7 for Intel Pentium (P54C/CQS/ CS, P55C), AMD 5k86, K5, K6, Cyrix 6x86 (L, M), IDT C6 processors, support 90/100/120/133/150/166/180/200/225/233/266/300MHz.
Memory	Expandable to 256MB (4 banks) with four 72-pin SIMM sockets onboard (Support Fast Page Mode and EDO DRAM 5-2-2-2) and two 168-pin DIMM socket (support Synchronous DRAM module 5-1-1-1).
Cache	64-bit 256/512KB L2 Pipeline Burst SRAM onboard.
I/O	Winbond 83977, two high speed 16550 compatible serial ports, one Multi-Mode. Parallel Port support SPP/EPP/ECP standard mode. Two onboard PCI DE Ports (32 bit data transfer). Support two 360/720KB/1.2/1.44/2.88MB floppy disk devices. One PS/2 Mouse port.
BIOS	Award System BIOS installed in socket (Flash and PnP).
Expansion slots	Four PCI Master Slots and three 16-bit ISA Slots.
Dimension	4-layer PCB, 2/3 baby size (220mm x 250mm).
Others	Support Ultra DMA/33, ACPI, SM Bus, GPID, USB Bus, Keyboard Power On/Off, Modem Ring On, ATX Power supply.

Setup Guide

A. Layout Diagram

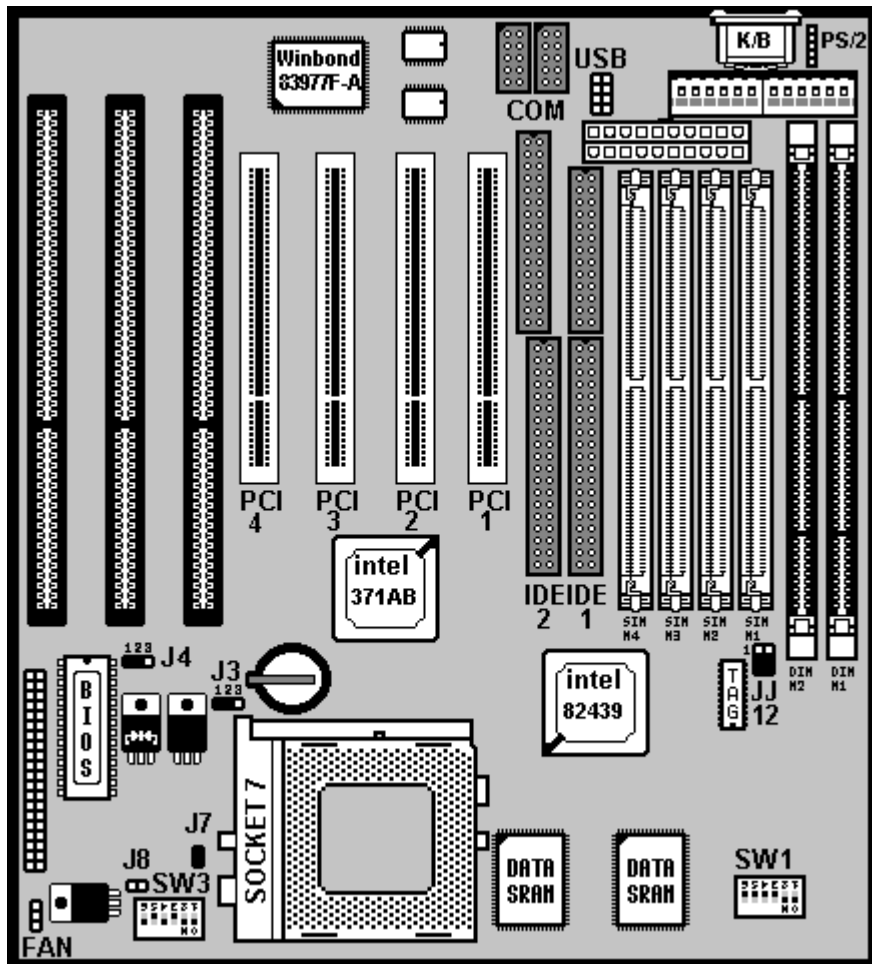

B. Switch Settings for CPUs

On = Short; Off = Open

Intel, AMD, Cyrix	SW1				SW1			
	1	2	3	RATE	4	5	6	CLK
Pentium 75 MHz	Off	Off	Off	1.5	X	X	X	50
Pentium 90 MHz	Off	Off	Off	1.5	On	Off	Off	60
Pentium 100 MHz	Off	Off	Off	1.5	Off	Off	Off	66
Pentium 120 MHz	On	Off	Off	2	On	Off	Off	60
Pentium 133 MHz	On	Off	Off	2	Off	Off	Off	66
Pentium 150 MHz	On	On	Off	2.5	On	Off	Off	60
Pentium (MMX) 166 MHz	On	On	Off	2.5	Off	Off	Off	66
Pentium (MMX) 200 MHz	Off	On	Off	3	Off	Off	Off	66
Pentium (MMX) 233 MHz	Off	Off	Off	3.5	Off	Off	Off	66
Pentium (MMX) 266 MHz	On	Off	On	4	Off	Off	Off	66
AMD-5k86-P75-75MHz	Off	Off	Off	1.5	X	X	X	50
AMD-5k86-P90-90MHz	Off	Off	Off	1.5	On	Off	Off	60
AMD-K5-75MHz -PR75	Off	Off	Off	1.5	X	X	X	50
AMD-K5-90MHz -PR90	Off	Off	Off	1.5	On	Off	Off	60
AMD-K5-100MHz-PR100	Off	Off	Off	1.5	Off	Off	Off	66
AMD-K5-90MHz-PR120	Off	Off	Off	1.5	On	Off	Off	60
AMD-K5-100MHz-PR133	Off	Off	Off	1.5	Off	Off	Off	66
AMD-K5-133MHz-PR166	On	On	Off	1.75	Off	Off	Off	66
AMD-K6(MMX)-166MHz	On	On	Off	2.5	Off	Off	Off	66
AMD-K6(MMX)-200MHz	Off	On	Off	3	Off	Off	Off	66
AMD-K6(MMX)-233MHz	Off	Off	Off	3.5	Off	Off	Off	66
AMD-K6(MMX)-266MHz	On	Off	On	4	Off	Off	Off	66
AMD-K6(MMX)-300MHz	On	On	On	4.5	Off	Off	Off	66
Cyrix 6x86-100MHz-P120+	On	Off	Off	2	X	X	X	50
Cyrix 6x86-110MHz-P133+	On	Off	Off	2	On	On	Off	55
Cyrix 6x86-120MHz-P150+	On	Off	Off	2	On	Off	Off	60
Cyrix 6x86-133MHz-P166+	On	Off	Off	2	Off	Off	Off	66
Cyrix 6x86-150MHz-P200+	On	Off	Off	2	Off	On	Off	75
Cyrix MX-150MHz-PR166	On	On	Off	2.5	On	Off	Off	60
Cyrix MX-166MHz-PR200	On	On	Off	2.5	Off	Off	Off	66
Cyrix MX-200MHz-PR233	Off	On	Off	3	Off	Off	Off	66
Cyrix MX-233MHz-PR266	Off	Off	Off	3.5	Off	Off	Off	66

C. CPU Voltage Settings

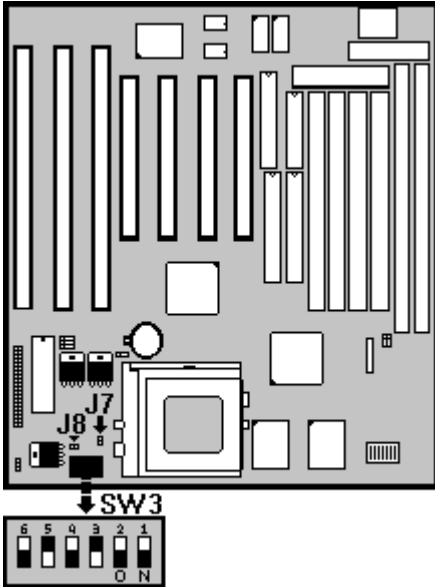

- The CPU voltage default setting is 3.30V(for Intel P54C), and J7=On(Short), J8=Off(Open).
- Switch voltage is applied, making the temperature lower and voltage steadier.
- All the voltage specifications adopted here are the averages of the working voltage suggested by the CPU makers, to make any CPU applied work with the best performance.
- Set the V I/O and Vcore to the same voltage, if you use a single voltage CPU.
- In Single voltage CPU

Single voltage CPU (Intel P54C, Cyrix 6x86, AMD 5k86/K5)			J7	J8			
3.52V		3.45V		3.30V		On	Off

Dual voltage CPU(Intel P55C, Cryrix 6x86L, MX-6x86, AMD-K6)			J7	J8			
V I/O 3.45V		V I/O 3.30V		Vcore 3.20V		Off	On
Vcore 2.90V		Vcore 2.80V		Vcore 2.20V			

D. CPU Frequencies

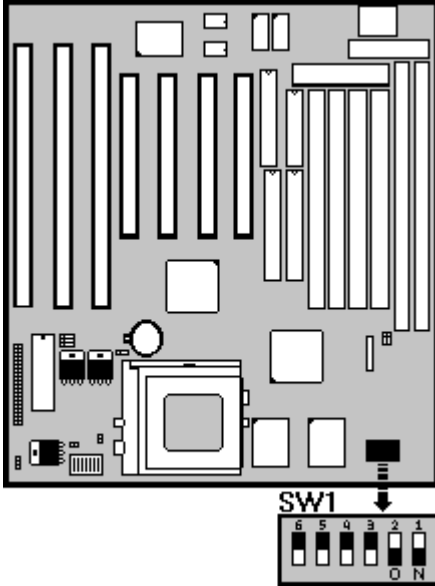

- The CPU type default setting is Intel Pentium 166MHz=66 MHz * 2.5.
- When a CPU with 75MHz is applied, the PCI Bus CLK output becomes 37MHz. Under this circumstance, some VGA cards may not fit well. Then the system becomes unsteady, tends to hang up easily or even results in boot failure. Use another VGA card instead when any of the above-mentioned conditions happens.

Multiplier Factor for Intel CPU							
1.5		2		2.5		3	
Multiplier Factor for AMD-K6 or Cyrix MX-6x86 CPU							
3.5		4		4.5		5	

Intel P54C	X1.5	X2	X2.5	X3			
Cyrix 6x86(L)	None	X2	None	None			
AMD-5k86/K5	X1.5	None	X1.75	None			
55 MHz		60 MHz		66 MHz		75 MHz	
	PCI Bus Clk 27 MHz	PCI Bus Clk 30 MHz	PCI Bus Clk 33 MHz	PCI Bus Clk 37 MHz			

E. DRAM, EDO RAM Installation Procedures:

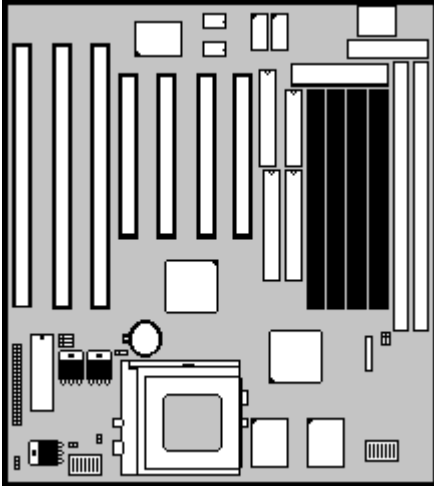

- SIMM Socket output voltage is 5V, expandable to 256MB.
 - Support 5V Fast Page Mode/ Extended Data Out RAM.
 - The BIOS DRAM default setting is 70 ns. Change the BIOS “Chipset Feature Setup” default setting to 60ns for better performance, if the chipset is marked 60ns.
-
- Change nothing if EDO RAM is used. BIOS automatically detects the RAM type.
 - With 586 CPUs, two FPM/EDO RAM Modules are required on SIMM sockets to compose a bank for the system to start.

F. SDRAM, Cache Memory Installation Procedures:

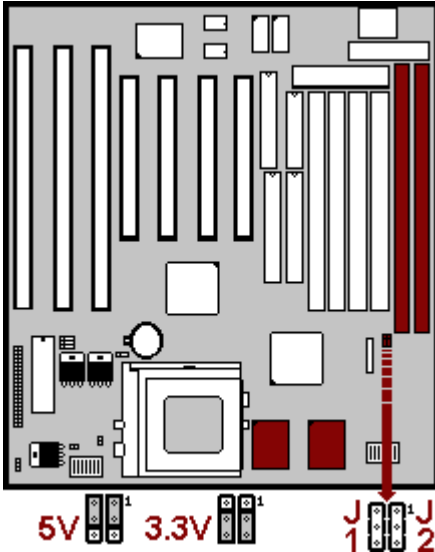

- A 168-pin DIMM can support up to 128MB EDO/SDRAM.
- Default setting: 3.3V.
- First, verify the working voltage of the EDO/SDRAM module in either DIMM socket (DIMM1 or DIMM2-table free).
- You can set up the BIOS "Chipset Feature Setup" to the best working condition basing on the type of EDO/SDRAM you are using.

- The Dual Inline Memory Module (DIMM) must be 3.3 Volt and Unbuffered Synchronous DRAM (SDRAM) 8MB, 16MB, 32MB or 64MB. The following illustration shows the type of DIMM Module.

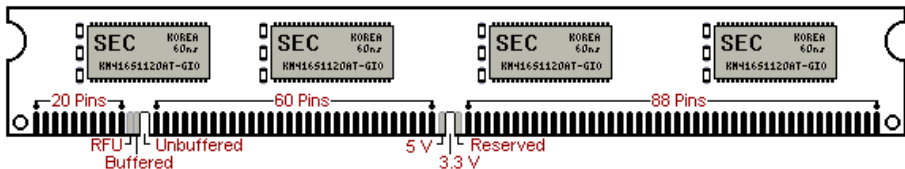

168-PIN SDRAM DIMM Notch Key Definitions

- Sync SRAM (Pipeline Burst SRAM) If Sync SRAM Modules are installed, they consists of Pipeline Burst 2 PCs 32K x 32-6 for 256KB or 2 PCs 64Kx32-6) for 512KB Sync SRAM.

G. Other Jumper Settings

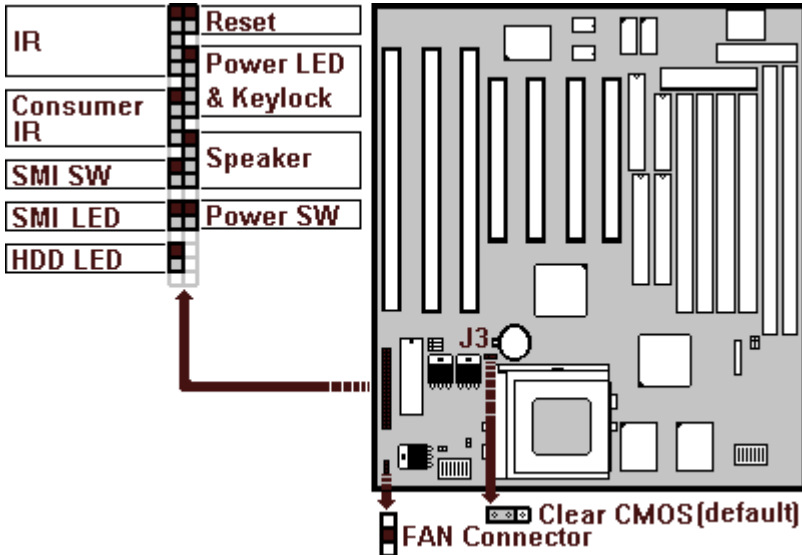

- **Speaker:**
Connect to the system's speaker for beeping.
- **Keylock:**
Keyboard lock switch and Power LED connector.
- **Reset:**
Short to restart system.
- **HDD LED:**
LED ON when on board PCI IDE hard disk activates.
- **SMI LED:**
LED ON when system is in any Saving mode.
- **Keyboard Power On/Off Function (Patent Is Under Application!!!)**
 1. Turn on the system by pressing the "Ctrl-***" keys simultaneously (Strike the "*" key 3 times while holding the "Ctrl" key.)
 2. Press "Ctrl-***" again to turn off the system. This function becomes invalid during POST (Power-On-Self-Test).
 3. CPU Fan Auto Turn Off: The CPU fan automatically turns off when the system enters the Suspend state. Remember to connect the CPU fan

to its connector on the mainboard to enable this function.

- **SMI SW:**

Short to enter sleep mode. A keystroke or mouse movement (mouse driver exits) will instantly “wake up” the system.

- **POWER SW (FOR ATX POWER SUPPLY):**

The button should be a momentary switch that is normally open. Pushing the ATX Power Switch will immediately change the system status. Before or during “POST”, you need to hold the button for four seconds in order to turn off the system.

- **J3: Clear CMOS**

Turn off the system and short pins 2-3 (J3) to clear CMOS. Then short pins 1-2 before turning it on. You may damage the chipset if you power on the system by shorting pins 2-3.

J3	
1-2	Normal operation(Default).
2-3	for clearing CMOS Data.

- **CPU Cooler Fan connector**

This is the connector for CPU cooler. Never use the jumper to short the connector. Serious damages caused this way will not be warrantied.

- **Modem Ring On Function Operation: (Only available by using ATX Power Supply)**

1. Enter BIOS setup.
2. Select Power Management Setup.
3. Resume by Ring: Enable.
4. Save BIOS setup and Reboot.
5. Booting from DOS, Windows, or Windows 95.
6. Turn off the system by:
 - a. ATX-Power Switch
 - b. Keyboard Power On/Off
 - c. Windows 95 Software Power Off
7. System Waiting for Modem Ring On

When Modem Ringing Signal Active, System will wake-up.

- USB1/USB2: USB Connector

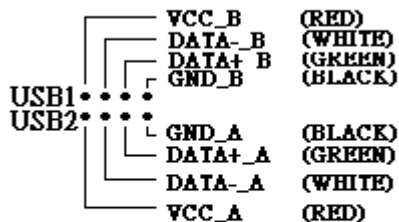

TM-586TX3 USB