



Thunder i7505



S2665

Revision 1.03

Copyright © TYAN Computer Corporation, 2002. All rights reserved. No part of this manual may be reproduced or translated without prior written consent from TYAN Computer Corp.

All registered and unregistered trademarks and company names contained in this manual are property of their respective owners including, but not limited to the following.

TYAN, Thunder i7505 S2665 are trademarks of TYAN Computer Corporation.

Intel, Xeon, and combinations thereof are trademarks of Intel Corporation.

Microsoft and Windows are trademarks of Microsoft Corporation.

Phoenix BIOS is a trademark of Phoenix Technologies.

Winbond is a trademark of Winbond Electronics Corporation.

Adaptec is a trademark of Adaptec Inc.

AnalogDevice and ADMare trademarks of Analog Devices Inc.

Sony/Philips Digital Interface (SPDIF) is a trademark of Sony Corporation and Philips Electronics.

PS/2 is a trademark of International Business Machines Corporation.

Portable Document Format (PDF) is a trademark of Adobe Corporation.

Information contained in this document is furnished by TYAN Computer Corporation and has been reviewed for accuracy and reliability prior to printing. TYAN assumes no liability and disclaims any express or implied warranty relating to sale and/or use of TYAN products; we also assume no including liability or warranties relating to fitness for a particular purpose or merchantability. TYAN retains the right to make changes to product descriptions and/or specifications at any time without notice. In no event will TYAN be held liable for any direct or indirect, incidental or consequential damage, loss of use, loss of data or other malady resulting from errors or inaccuracies of information contained in this document.

Table of Contents

Before you begin...	Page 3
Chapter 1: Introduction	Page 4
1.1 Congratulations	Page 4
1.2 Hardware Specifications	Page 4
Chapter 2: Board Installation	Page 6
2.0 Board Image	Page 7
2.1 Board Parts, Jumpers and Connectors	Page 8
2.2 Jumper and Connector Settings	Page 9
2.3 AUX Audio and CD Audio Connector	Page 10
2.4 Enable/Disable On board LAN Jumper	Page 10
2.5 Fan Connectors	Page 10
2.6 ACPI Wake-up Jumper for PS/2	Page 11
2.7 ACPI Wake-up Jumper for USB Port A ~ D	Page 11
2.8 Slot-A PCI-X/PCI-2.2 Jumper	Page 11
2.9 Slot-B and Slot-C PCI-X/PCI-2.2 Jumper	Page 12
2.10 Clear CMOS Jumper	Page 12
2.11 ACPI Wake-up Jumper for USB Port E ~ F	Page 12
2.12 IEEE 1394 Connectors	Page 13
2.13 LCD Connectors Chassis Intrusion Connector	Page 13
2.14 Front Panel Audio Connector	Page 13
2.15 Chassis Intrusion Connector	Page 14
2.16 Front Panel USB Header	Page 14
2.17 Front Panel Connector	Page 15
2.18 SCSI RAID PCI Slot-C	Page 15
2.19 OEM Reserved Connectors and Jumpers	Page 15
2.20 Mounting the Motherboard	Page 16
2.21 Installing the Memory	Page 16
2.22 Installing the Processor and Heatsink	Page 18
2.23 Installing Add-In Cards	Page 20
2.24 Connecting External Devices	Page 21
2.25 Installing the Power Supply	Page 22
2.26 Attaching IDE and Floppy Drive Cables	Page 23
2.27 Finishing Up	Page 24
Chapter 3: BIOS	Page 25
3.0 BIOS Setup Utility	Page 25
3.1 BIOS Menu Bar	Page 26
3.2 BIOS Legend Bar	Page 26
3.3 BIOS Main Menu	Page 27
3.4 BIOS Advanced Menu	Page 28
3.5 BIOS Security Menu	Page 31
3.6 BIOS Power Menu	Page 31
3.7 BIOS Boot Menu	Page 32
3.8 BIOS Exit Menu	Page 33
Chapter 4: Diagnostics	Page 34
4.1 Beep Codes	Page 34
4.2 Flash Utility	Page 34
Appendix I: Glossary	Page 35
Technical Support	Page 39

Before you begin...

Check the box contents!

The retail motherboard package should contain the following:



1x Thunder i7505 S2665



1x 34-Pin floppy drive cable



1x Ultra160/320 LVD SCSI cable (if optional SCSI included)



1x Ultra-DMA-100/66/33 IDE cable



1x Thunder i7505 S2665 User's Manual



1x TYAN driver CD



1x Adaptec Ultra160/Ultra320 SCSI driver diskette (if optional SCSI included)



1x I/O shield

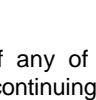

2X CPU retention

If any of these items are missing, please contact your vendor/dealer for replacement before continuing with the installation process.

Chapter 1: Introduction

1.1 – Congratulations!

You are now the owner of one of the most advanced dual Intel Xeon processor solutions available: the Thunder i7505 S2665. Based on Intel's E7505 chipset, the Thunder i7505 S2665 is **Hyper-Threading** ready - utilizing onboard resources so that many data threads can be handled with ease by two processors.

With a **8x/4x AGP** slot, six **USB 2.0** and 1.1 compatible ports, two **FireWire** (IEEE-1394) ports, four DDR DIMM sockets, a **Gigabit Ethernet** port, plus an optional Dual Channel Ultra320 SCSI, the Thunder i7505 S2665 is fast and flexible enough to fit your server needs.

Remember to visit TYAN's Website at <http://www.tyan.com>. There you can find information on all of TYAN's products with FAQs, distributors list and BIOS setting explanations.

1.2 – Hardware Specifications

Processor

- Dual mPGA604 ZIF sockets
- Supports one or two Intel Xeon processors with 512KB of integrated L2 cache
- Onboard 4-phase VRM (VRM 9.1 spec)
- Supports 400/533MHz Front-Side Bus

Chipset

- Intel E7505 chipset
- MCH + ICH4 + P64H2 + FWH
- Intel P64H2 supports two PCI-(X) buses
- Winbond W83627HF Super I/O chip
- Analog Device ADM1027 systems monitor and multiple fan controller

Memory

- Four 184-pin 2.5-Volt DDR DIMM sockets
- Dual channel memory bus
- Supports ECC/non-ECC type unbuffered memory modules
- Supports PC1600/PC2100 DDR (DDR200/DDR266)
- Maximum 4 GB

Expansion Slots

- Three independent PCI-(X) buses
- One 8x/4x mode AGP Pro50 slot
- One 64-bit 133/100/66MHz (3.3-Volt) PCI-X slot
- Two 64-bit 100/66MHz (3.3-Volt) PCI-X slot
- Two 32-bit 33MHz (5-Volt) PCI slots
- Total of six usable slots

Integrated SCSI (Manufacturing Option)

- Adaptec 7902 dual channel Ultra160/320 SCSI at PCI-X 100MHz
- Intel RAIDIOS and Adaptec Zero-Channel RAID ready through a PCI slot

Integrated LAN

- Intel 82540EM Gigabit Ethernet
 - (Manufacture loading option with Intel 82551QM 10/100Mbit Ethernet)

Integrated Audio

- Intel ICH4 AC'97 compliant audio link
- AD1981A CODEC
- Line-in, Line-out, Mic-in rear jacks
- SPDIF digital output with rear RCA connector
- Front panel audio header
- One 4-pin CD-ROM audio input header
- One 4-pin Auxiliary header

BIOS

- Phoenix BIOS 6.0 on 4/8Mbit Flash ROM
- Supports Hyper-Threading technology
- Supports BIOS Boot Specification v1.1 (BBS)
- Supports ACPI
- Supports SMBIOS v2.3
- Support LAN remote boot (PXE)
- Auto configuration of IDE hard disk types

Integrated 1394

- TI TSB43AB22 single-chip solution
- Two ports (one on rear panel and one header for the front panel via an optional cable)

Integrated PCI IDE

- Provides two PCI bus master channels for up to four Enhanced IDE devices
- Supports for UDMA 33/66/100 IDE drives and ATAPI compliant devices
- Supports up to four Enhanced IDE devices

Integrated I/O

- Six USB 2.0 and 1.1 compatible ports (4 rear connectors and 2 front panel headers via an optional USB cable)
- Supports one floppy drive with 3 mode
- One 9-pin serial connector
- One 25-pin ECP/EPP/SPP parallel connector
- PS/2 mouse and keyboard connectors
- Two IEEE1394 (firewire) ports (1 rear connector and 1 front connector)
- One SPDIF RCA connector

System Management

- Total seven 3-pin fan headers
- Six fan headers with tachometer monitoring
- One 3-pin Chassis Intrusion header
- Temperature, voltage and fan monitoring

Form Factor

- SSI EEB v3.0 footprint (12" x 13")
- 8-layer design
- EPS12V
- Stacked PS/2 keyboard and mouse ports
- Stacked four USB2.0/1.1 ports
- Stacked one serial port and one parallel port
- One RJ45 LAN port with LEDs
- One IEEE-1394 port
- One SPDIF RCA port
- Audio Line-in, HI-out, and Mic-in ports (Amplifier integrated)

Regulatory

- FCC DoC (Declaration of Conformity)
- European CE (Declaration of Conformity)

Chapter 2: Board Installation

Installation

You are now ready to install your motherboard. The mounting hole pattern of the Thunder i7505 S2665 matches the EEB V3.0 specification. Before continuing with installation, confirm that your chassis supports a standard EEB V3.0 motherboard.

How to install our products right....the first time!

The first thing you should do is read this user's manual. It contains important information that will make configuration and setup much easier. Here are some precautions you should take when installing your motherboard:

- (1) Ground yourself properly before removing your motherboard from the antistatic bag. Unplug the power from your computer power supply and then touch a safely grounded object to release static charge (i.e. power supply case). For the safest conditions, Tyan recommends wearing a static safety wrist strap.
- (2) Hold the motherboard by its edges. Do not touch the bottom of the board or flex the board in any way.
- (3) Avoid touching the motherboard components, IC chips, connectors, memory modules, and leads.
- (4) Place the motherboard on a grounded antistatic surface or on the antistatic bag that the board was shipped in.
- (5) Inspect the board for damage.

The following pages include details on how to install your motherboard into your chassis, as well as installing the processor, memory, disk drives and cables.

NOTE DO NOT APPLY POWER TO THE BOARD IF IT HAS BEEN DAMAGED

WARNING:

The Thunder i7505 S2665 only supports EPS12V power supplies and will not operate with other types. DO NOT use ATX 2.x, ATX12V and dual AMDGES power supplies as they will damage the board and void your warranty.

Only EEB V3.0 form factor chassis is supported. Other form factors may short the board because the installation studs are in different locations.

2.0– Board

The following is an image of the S2665.

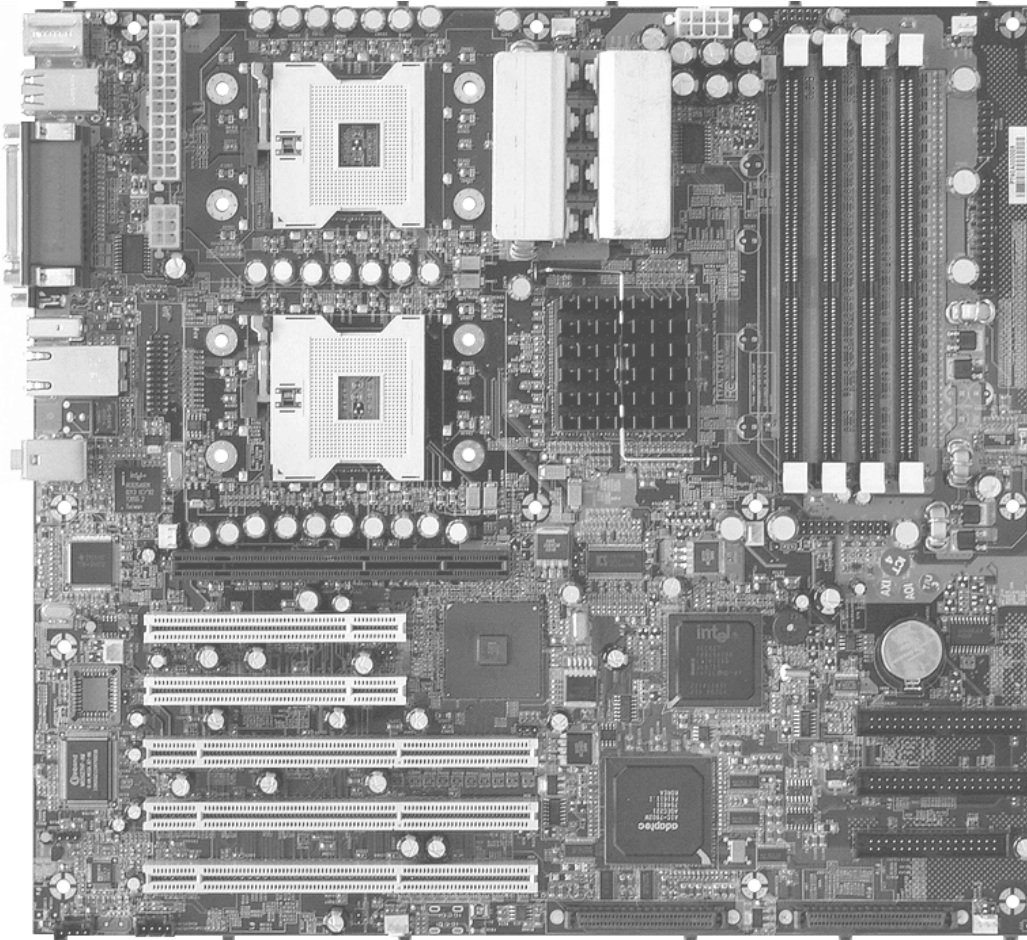

This picture is representative of the latest board revision available at the time of publishing. The board you receive may or may not look exactly like the above picture.

The following page includes details on the vital components of this motherboard.

2.1 – Board Parts, Jumpers and Connectors

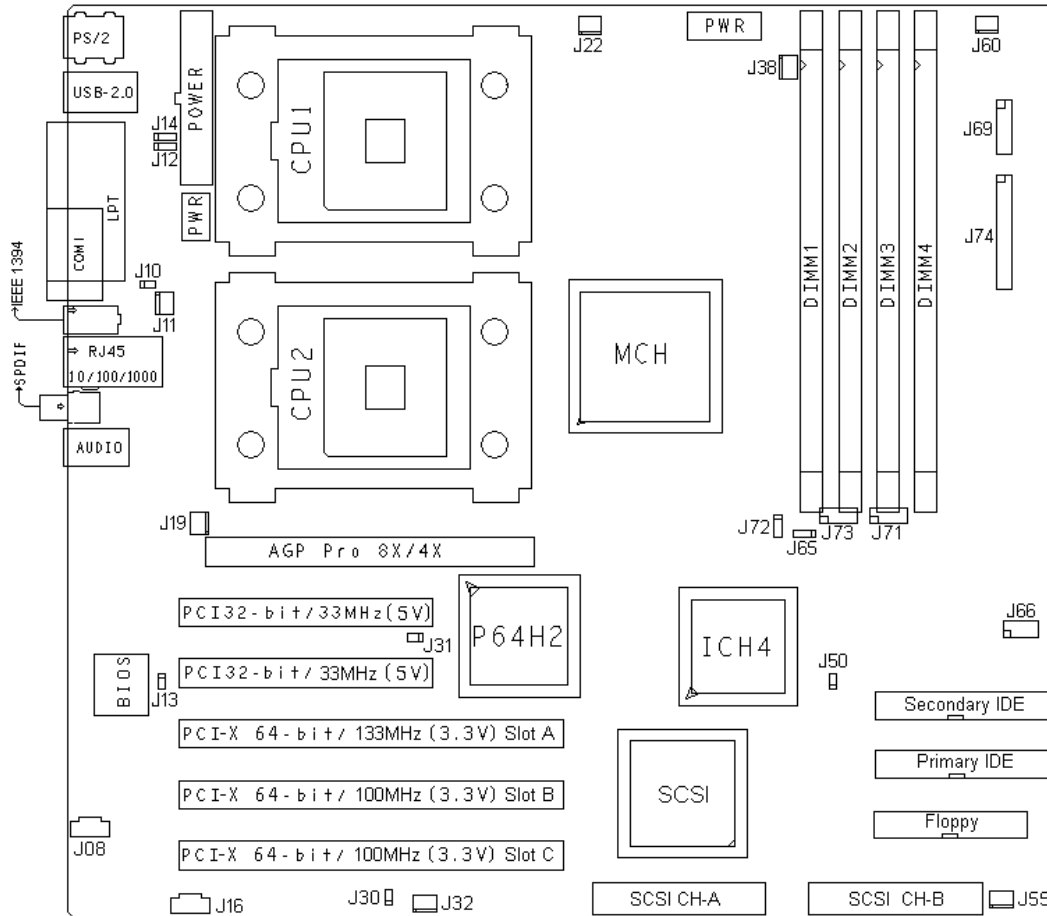

This diagram is representative of the latest board revision available at the time of publishing. The board you receive may not look exactly like the above diagram.

Jumper Legend

	Jumper OFF	without jumper cover
	Jumper ON	with jumper cover

	To indicate where the location of pin-1
	To indicate where the location of pin-1

2.2– Jumper and Connector Settings

Jumper / Connector	Function	Settings
J8	AUX Audio Connector	
J10	Enable/Disable Onboard Intel 82540EM GbE NIC	Open: Enable (Default) Close: Disable
J11	Fan Connector	With tachometer monitoring
J12	ACPI Wake-up Jumper (PS/2 keyboard and PS/2 mouse)	Close Pin-1 and Pin-2 (Default) PS/2 devices' ACPI S1 wake up Close Pin-2 and Pin-3 PS/2 devices' ACPI S1/S4 wake up function
J14	ACPI Wake-up Jumper (USB Port-A, USB Port-B, USB Port-C and USB Port-D)	Close Pin-1 and Pin-2 (Default) Rear panel USB devices' ACPI S1 wake up Close Pin-2 and Pin-3 Rear panel USB devices' ACPI S1/S4 wake up
J16	CD Audio Input Connector	
J19	Fan Connector	With tachometer monitoring
J22	Fan Connector	With tachometer monitoring
J30	Slot-A PCI-X/PCI-2.2 Jumper	Open: PCI-X Compatible (Default) Close: PCI-2.2 Compatible
J31	Slot-B, Slot-C and Onboard SCSI PCI-X/PCI-2.2 Jumper	Open: PCI-X Compatible (Default) Close: PCI-2.2 Compatible
J32	Fan Connector	With tachometer monitoring
J38	Fan Connector	Without tachometer monitoring
J50	Clear CMOS Jumper	Open: Normal (Default) Close: Clear CMOS Mode
J55	Fan Connector	With tachometer monitoring
J60	Fan Connector	With tachometer monitoring
J65	ACPI Wake-up Jumper (USB Port-E and USB Port-F)	Close Pin-1 and Pin-2 (Default) Front panel USB devices' ACPI S1 wake up Close Pin-2 and Pin-3 Front panel USB devices' ACPI S1/S4 wake up
J66	IEEE 1394 Connector	
J69	LCD Connector	
J71	Front Panel Audio Connector	
J72	Chassis Intrusion Connector	
J73	Front Panel USB Connector	
J74	Front Panel Connector	

2.3– AUX Audio Connector (J8) and CD Audio Connector (J16)

	<p>J 8 (AUX Audio connector)</p>
	<p>Connects to internal audio sources such as TV tuner, MPEG, or other similar cards</p>
	<p>J16 (CD Audio connector)</p>
<p>Connects to a CD-ROM drive via an optional CD audio cable</p>	

2.4– Enable/Disable Onboard LAN Jumper (J10)

	<p>OPEN (Default) To enable onboard LAN</p>
	<p>CLOSE To disable onboard LAN</p>

2.5– Fan Connectors (J11, J19, J22, J32, J38, J55 and J60)

	<p>Use these headers to connect chassis and processor cooling fans to your motherboard. Cooling fans can keep the system stable and reliable for its product life.</p> <p>Max 850mA fans supported</p>

2.6 – ACPI Wake-up Jumper (J12)

	<p>pin-3</p>
	<p>CLOSE Pins 1 and 2 (Default) PS/2 devices' ACPI S1 wake up</p>
	<p>pin-3</p>
	<p>CLOSE Pins 2 and 3 PS/2 devices' ACPI S1/S4 wake up</p>

2.7 – ACPI Wake-up Jumper for USB Port-A, Port-B, Port-C and Port-D (J14)



	<p>pin-3</p>
	<p>CLOSE Pins 1 and 2 (Default) Rear panel USB devices' ACPI S1 wake up</p>
	<p>pin-3</p>
	<p>CLOSE Pins 2 and 3 Rear panel USB devices' ACPI S1/S4 wake up Total current of all USB devices should not exceed the standby current rating of the power supply</p>

2.8 – Slot-A PCI-X/PCI-2.2 Jumper (J30)

	<p>OPEN (Default) To switch Slot-A to PCI-X compatible mode</p>
	<p>CLOSE To switch Slot-A to PCI-2.2 compatible mode</p>

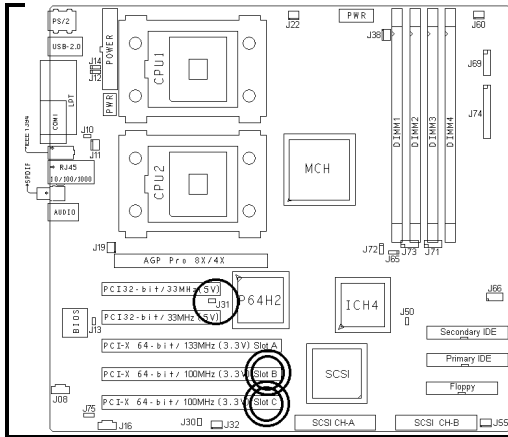

2.9 – Slot-B and Slot-C PCI-X/PCI-2.2 Jumper (J31)



	OPEN (Default) To switch Slot-B, Slot-C and onboard SCSI to PCI-X compatible mode
	CLOSE To switch Slot-B, Slot-C and onboard SCSI to PCI-2.2 compatible mode

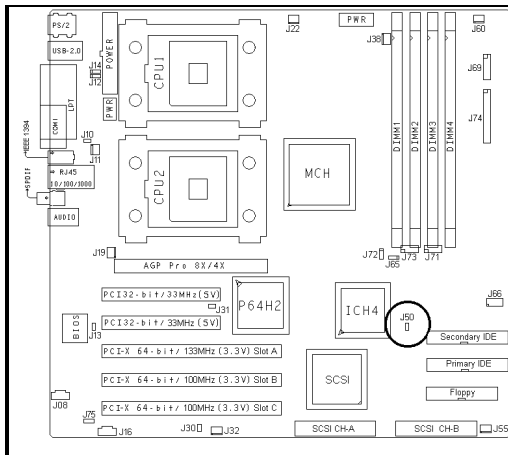

2.10– Clear CMOS Jumper (J50)

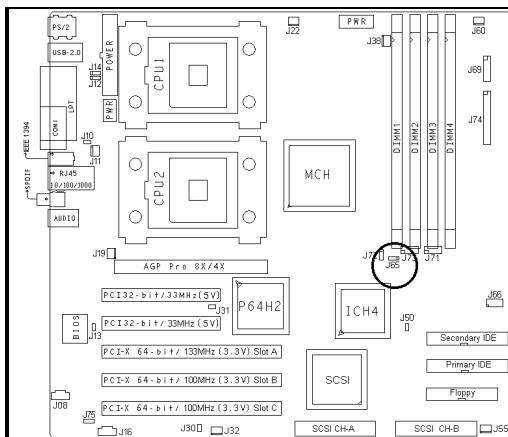

	Clear		Default
<p>You can reset the CMOS settings by using this jumper when you</p> <ul style="list-style-type: none"> ▪ Have forgotten your system/setup password ▪ Need to clear system BIOS setting <ul style="list-style-type: none"> - Power off system and disconnect power supply from AC source - Use jumper to close JP50 for several seconds to Clear CMOS - Take off jumper from JP50 (default setting) - Reconnect power supply to AC source - Power on system - Use “F2” key to go into system BIOS setup 			

2.11 – ACPI Wake-up Jumper for USB Port-E and Port-F (J65)



	pin-1
CLOSE Pins 1 and 2 (Default) Front panel USB devices' ACPI S1 wake up	
	pin-1
CLOSE Pins 2 and 3 Front panel USB devices' ACPI S1/S4 wake up Total current of all USB devices should not exceed the standby current rating of the power supply	

2.12 – IEEE 1394 Connector (J66)

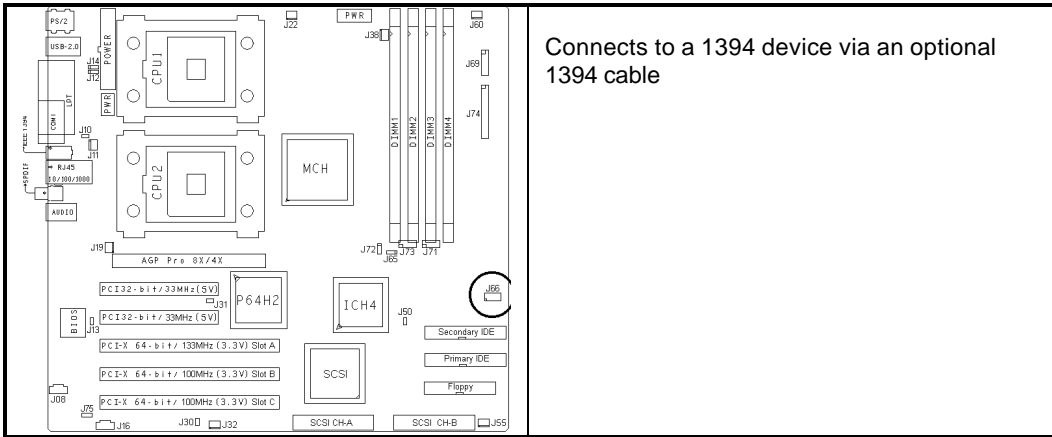

2.13 – LCD Connector (J69)

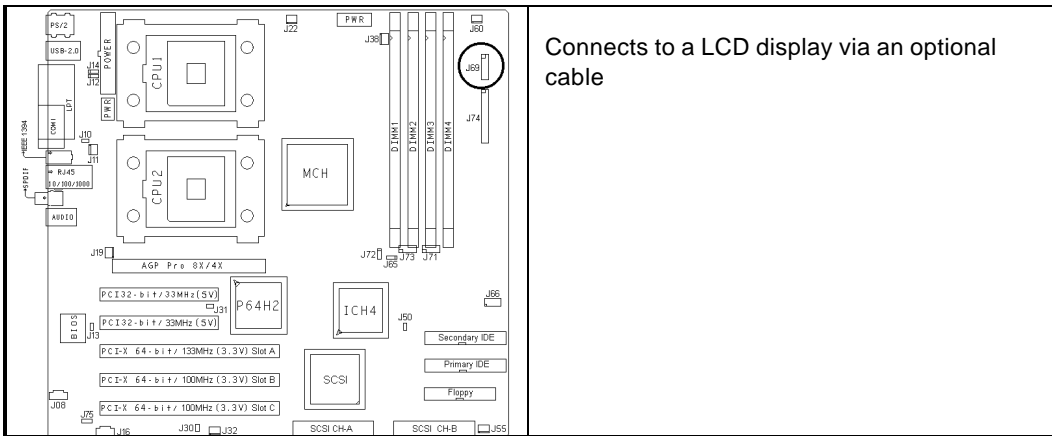

2.14 – Front Panel Audio Connector (J71)

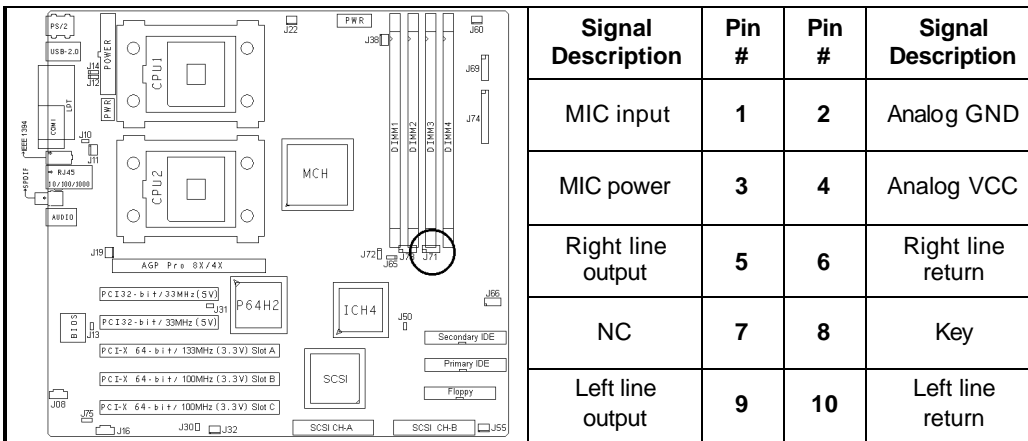

2.15 – Chassis Intrusion Connector (J72)

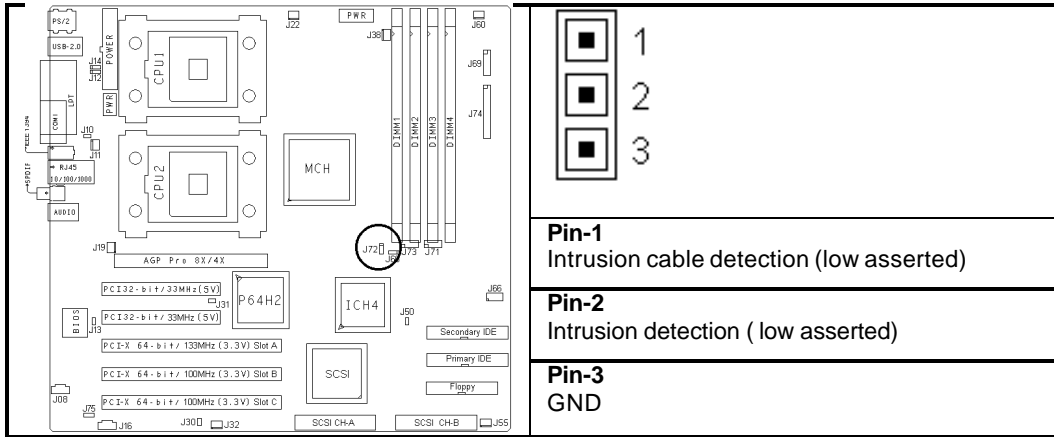

2.16 – Front Panel USB Header (J73)

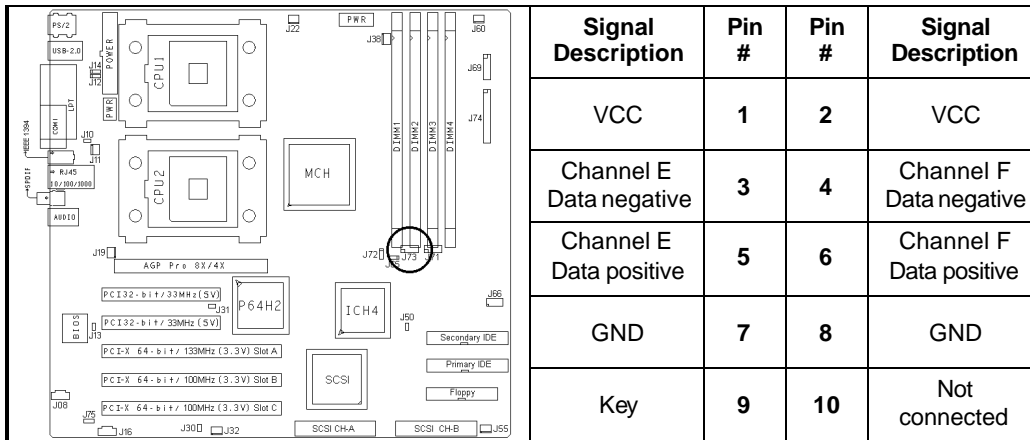

2.17 – Front Panel Connector (J74)

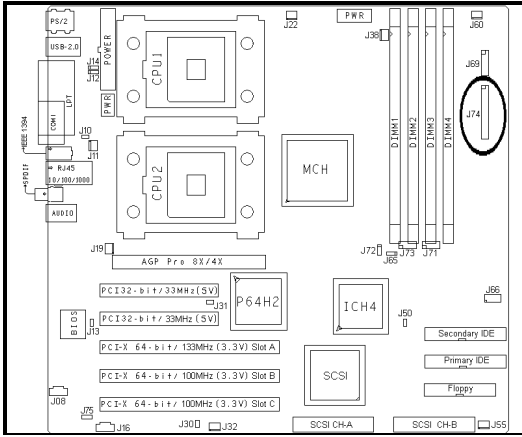

Signal Description	Pin #	Pin #	Signal Description
Sleep LED “-“	1	2	Speaker “-“
Sleep LED “+“	3	4	Key
Key	5	6	GND
Power LED “+“	7	8	Speaker “+“
Power LED “-“	9	10	Key
GND	11	12	Key
Message LED “+“	13	14	Key
Message LED “-“	15	16	Not connected
Key	17	18	SCSI LED Input
HD LED “+“	19	20	SCSI LED Input
HD LED “-“	21	22	Not connected
GND	23	24	Key
Power Button	25	26	GND
Sleep Button	27	28	GND
Reset Button	29	30	GND

2.18 – SCSI RAID PCI Slot-C

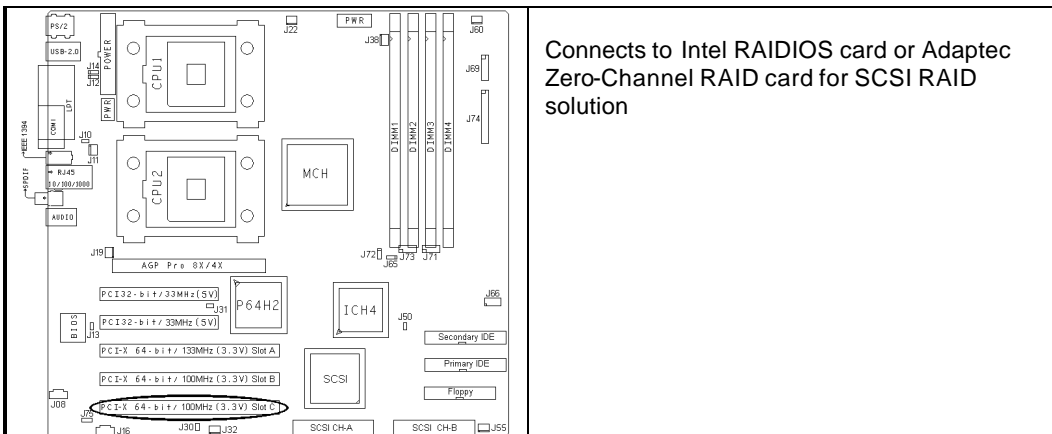

2.19 – OEM Reserved Connectors and Jumpers

These connectors and jumpers which are not listed are reserved for OEM use only.

2.20 – Mounting the Motherboard

Before installing your motherboard, make sure your chassis has the necessary motherboard support studs installed. These studs are usually manufacturer pre-installed, metal and are gold in color. If you are unsure of stud placement, lay the motherboard inside the chassis and align the studs.

NOTE

YOU MUST make sure that there are no studs where there are no screw holes.

2.21 – Installing the Memory

Before attempting to install any memory, here are a few key points to note before installing memory modules onto your board.

- Memory modules must be installed in pairs (**DIMM1+DIMM2 or DIMM3+DIMM4**)
- At least two unbuffered DDR ECC/non-ECC modules must be installed
- All installed memory will be automatically detected - no need to set any jumpers
- Supports 128MB, 256MB, 512MB and 1GB unbuffered DDR200/266 modules
- Supports up to 4GB of memory

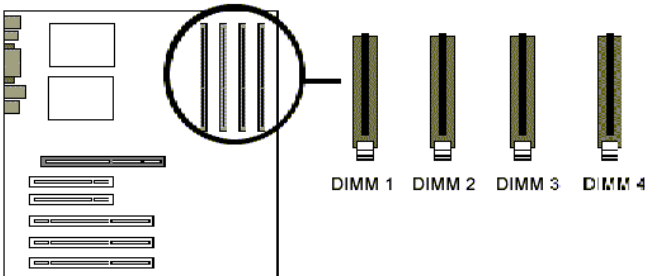

DIMM1 + DIMM2

Or

DIMM3 + DIMM4

Or

DIMM1 + DIMM2 +
DIMM3 + DIMM4

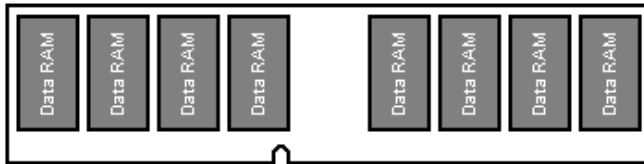

DDR Unbuffered Non-ECC

V supported



DDR Unbuffered ECC

V supported

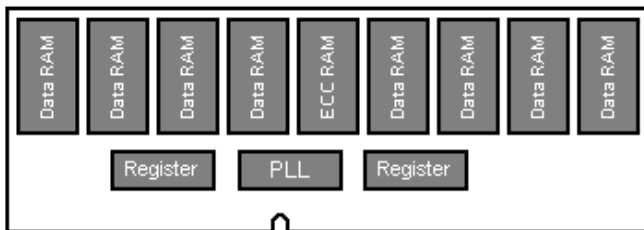

DDR Registered ECC

X unsupported

Make sure that the memory you have is compatible with the motherboard as well as the processor. For example, **DDR200 and DDR266 memory modules can be used for FSB=400MHz Intel Xeon processor but only DDR266 memory modules can be used for FSB=533MHz Intel Xeon processor.**

	DDR200 (PC1600)	DDR266 (PC2100)
Xeon FSB=400MHz	✓ supported	✓ supported
Xeon FSB=533MHz	X unsupported	✓ supported

Memory Installation Procedure

When installing memory modules, make sure the modules align properly with the memory socket. There should be a key (small indent) on your memory module that fits according to the key in the memory socket. DDR modules and sockets have only one key, which is slightly off-center of the module/socket. The method of installing memory modules is detailed in the following diagrams.

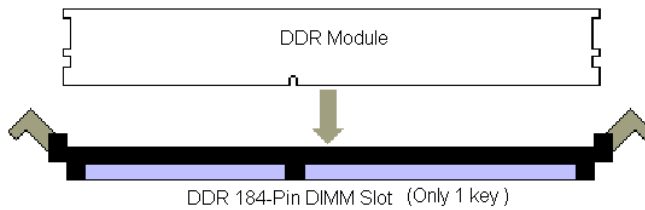

Once the memory modules are firmly seated in the socket, two clamps on either side will close and secure the module into the socket. Sometimes you may need to close the clamps manually.

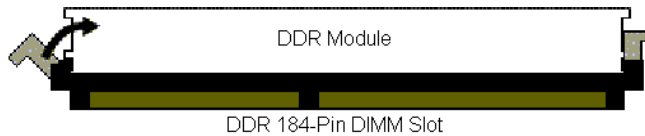

To remove the memory module, simply push the clamps outwards until the memory module pops up. Then remove the module.

TIP: When installing memory, a module may require a considerable amount of force to seat properly, although this is very rare. To avoid bending and damaging your motherboard, place it on its anti-static bag and onto a flat surface, then proceed with memory installation.

For important memory information, please check Tyan's web site at www.tyan.com for recommendations.

NOTE

YOU MUST unplug the power supply before performing system hardware changes in order to avoid damaging the board or expansion device.

2.22 – Installing the Processor(s) and Heatsink(s)

Your Thunder i7505 S2665 supports the latest processor technologies from Intel. Check the following page on TYAN's website <http://www.tyan.com> for latest processor support:

The following diagrams will detail how to install your processor(s):

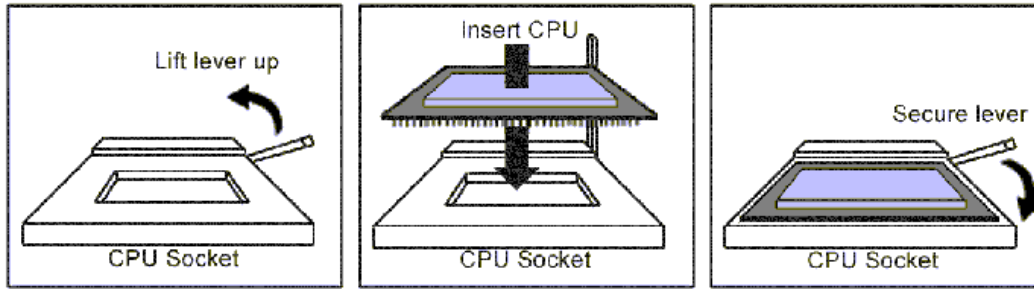

REMINDER

Only **identical** CPUs can be used.

When installing only 1 processor, ensure to install it in **CPU socket 1** . (see page-8)

The processors you choose to use may not look exactly like the one pictured above, nor will the socket look exactly the same. The diagram is a visual guide to help you install processors.

1. **Lift the lever on the socket as far back as possible to the socket.**
2. Align the processor with the socket. There are keys underneath the processor just like on memory modules to ensure that they insert the correct way.
3. Seat the processor firmly into the socket by gently pressing down until the processor sits flush with the socket.
4. Place the socket lever back down until it snaps into place.
5. Your processor is installed.
6. Repeat these steps for the second processor if you are using two processors.

Take extra care when installing Xeon processors as they have fragile connector pins that can bend and break if inserted improperly.

Heatsink Installation

After you are done installing the processor(s), you should proceed to installing their heatsink(s). Heatsinks will ensure that the processors do not overheat and continue to operate at maximum performance for as long as you own them. Overheated processors may damage the motherboard.

Because there are many different types of heatsinks available from many different manufacturers, a lot of them have their own method of installation. For the safest method of installation and information on choosing the appropriate heatsink, please refer to Intel's website at <http://www.intel.com>.

The following diagram will illustrate how to install the most common heatsinks:

- a. Align the heatsink mounting bracket to the holes around the processor socket

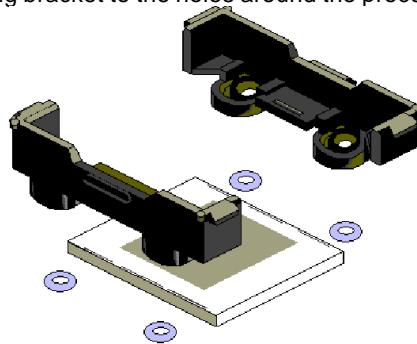

- b. Insert Black securing peg into bracket holes

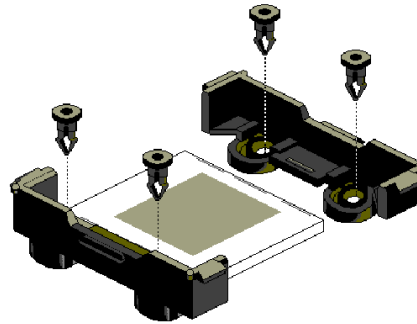

- c. Insert White locking peg into Black securing peg

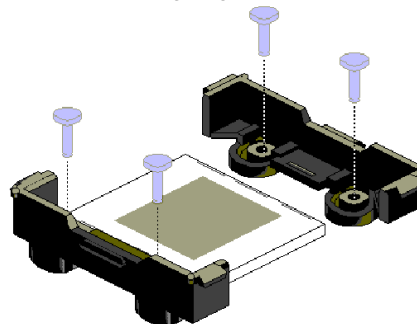

- d. Repeat process to mount all other brackets
- e. Seat heatsink between brackets on the processor
- f. Attach heatsink clips

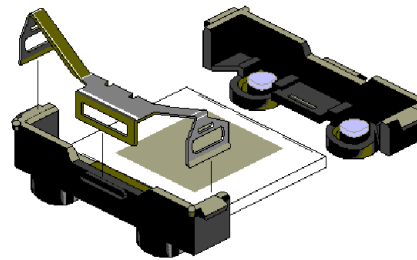

Finishing Installing the Heatsink

After you finish installing the heatsink onto the processor and socket, attach the end wire of the fan (which should already be attached to the heatsink) to the motherboard. The following diagram illustrates how to connect fans onto the motherboard.

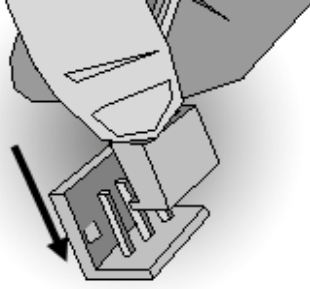

After you have finished installing all the fans you can connect your drives (hard drives, CD-ROM drives, etc.) to your motherboard.

2.23 – Installing Add-In Cards

Before installing add-in cards, it is helpful to know if they are fully compatible with your motherboard. For this reason, we have provided the diagrams below showing the most common slots that may appear on your motherboard. Not all of the slots shown will necessarily appear on your motherboard. However, there will be combinations of what you see here.

AGP PRO 50 Slot



AGP Slot



PCI-X/PCI 64-bit 3.3v Slot

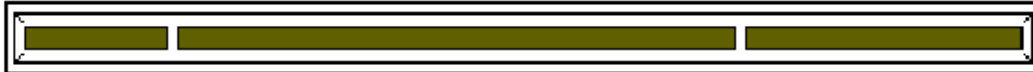

PCI 32-bit 5v Slot

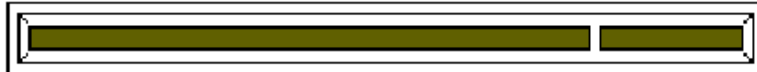

Find the appropriate slot for your add-in card and insert the card firmly. Do not force any add-in cards (or anything else) into any slots if they will not seat in place.

NOTE





YOU MUST unplug the power supply before performing system hardware changes in order to avoid damaging the board or expansion device.

Before Continuing onto section **Connecting External Devices**, make sure everything is properly connected. Things like jumpers and case wiring are the most common causes of troubleshooting frustrations, both for the end-user and for any company doing technical support.

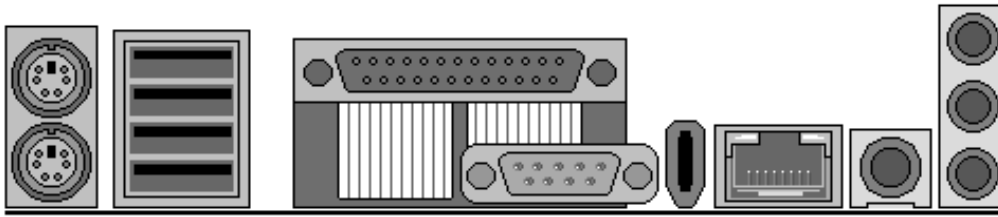
2.24 – Connecting External Devices

The following diagrams will detail the rear port stack for this S2665 motherboard:

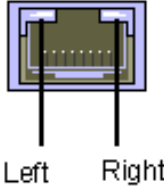

<p>a. Audio Port</p>  <p>Blue = Line in Green = Line out Pink = Mic in</p>	<p>Line In Jack Connects to external devices for playback or recording</p> <p>Line Out Jack Connects to headphone or speakers (Amplifier integrated)</p> <p>Microphone In Jack Connects to an external microphone</p>												
<p>b. USB 2.0/1.1</p>  <p>USB A USB B USB C USB D</p>	<p>USB 2.0/1.1 Four rear USB 2.0/1.1 connectors Port-A, Port-B, Port-C and Port-D Two front USB 2.0/1.1 headers (J73) Port-E and Port-F</p>												
<p>c. SPDIF</p> 	<p>SPDIF RCA connector Sony/Philips Digital Interface (SPDIF) is the newest audio transfer file format. It provides impressive sound quality through this RCA connector and allows you to enjoy digital audio instead of analog audio.</p>												
<p>d. RJ45 LAN Port</p> 	<p>RJ45 Link/Activity LED (Right Side)</p> <table border="1" style="margin-left: 20px;"> <tr> <td>Without LINK</td> <td>Green LED OFF</td> </tr> <tr> <td>With LINK</td> <td>Green LED ON</td> </tr> <tr> <td>Activity</td> <td>Green LED BLINK</td> </tr> </table> <p>RJ45 Speed LED (Left side)</p> <table border="1" style="margin-left: 20px;"> <tr> <td>1000</td> <td>Green LED ON</td> </tr> <tr> <td>100</td> <td>Yellow LED ON</td> </tr> <tr> <td>10</td> <td>LED OFF</td> </tr> </table>	Without LINK	Green LED OFF	With LINK	Green LED ON	Activity	Green LED BLINK	1000	Green LED ON	100	Yellow LED ON	10	LED OFF
Without LINK	Green LED OFF												
With LINK	Green LED ON												
Activity	Green LED BLINK												
1000	Green LED ON												
100	Yellow LED ON												
10	LED OFF												
<p>e. IEEE 1394</p> 	<p>IEEE 1394 connector One rear IEEE 1394 Firewire connector One front IEEE 1394 Firewire header J66 (See page -8 for jumper J66)</p>												

2.25- Installing the Power Supply

There are three power connectors on your Thunder i7505 S2665. By default, the Thunder i7505 S2665 requires that you have an EPS12V power supply that has a 24-pin and an 8-pin power connector. The extra 6-pin AUX power connector is recommended if you plan on using an AGP Pro video card. Please be aware that ATX 2.x, ATX12V and dual ATXGES (24+8-pin) power supplies are **not compatible** with the board.

EPS 12V power connector	24-pin power connector	8-pin power connector	6-pin power connector
S2665 with PCI/AGP video card	Required	Required	Not required
S2665 with AGP Pro video card	Required	Required	Recommended

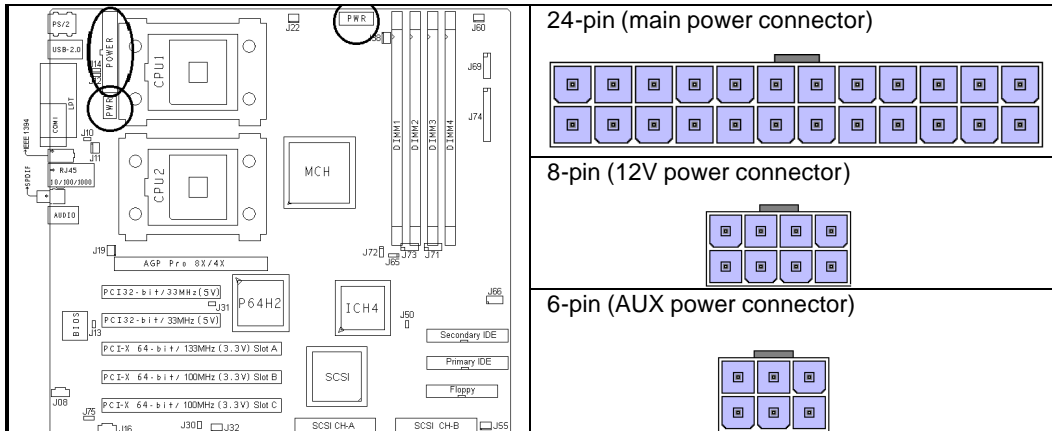

1. Disconnect power supply from electrical outlet
2. Connect 8-pin 12V power connector
3. Connect 6-pin AUX power connector (recommended if using an AGP pro video card)
4. Connect 24-pin main power connector
5. Connect power cable to power supply to power outlet

NOTE

Certain EPS12V power supplies do not have the 6-pin AUX power connector. Please check with your power supply vendors if you plan to use an AGP Pro video card.

NOTE

YOU MUST unplug the power supply before plugging the 24-pin, 8-pin and 6-pin cables to motherboard connectors.

2.26 – Attaching IDE and Floppy Drive Cables

Attaching IDE drive cabling is simple. These cables are “keyed” to only allow them to be connected in the correct manner. Tyan motherboards have two on-board IDE channels, each supporting two drives. **The black connector designates the Primary channel, while the white connector designates the Secondary channel.**

Attaching IDE cables to the IDE connectors is illustrated below

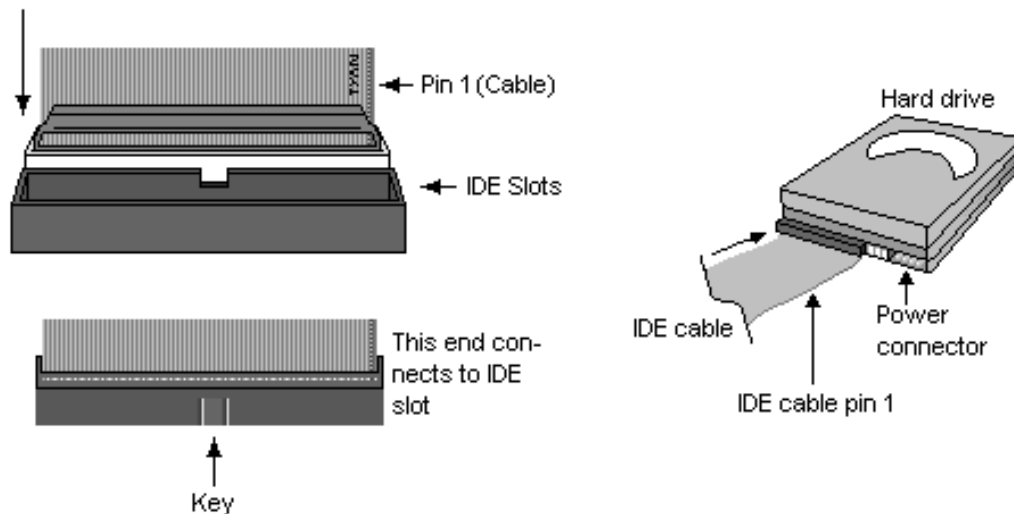

Simply plug in the BLUE END of the IDE cable into the motherboard IDE connector, and the other end(s) into the drive(s). Each standard IDE cable has three connectors, two of which are closer together. The BLUE connector that is furthest away from the other two is the end that connects to the motherboard. The other two connectors are used to connect to drives.

Attaching a floppy drive can be done in a similar manner to an IDE drive. Most of the current floppy drives on the market require that the cable be installed with the colored stripe (pin-1) positioned next to the power connector. In most cases, there will be a key pin on the cable which will force proper connection of the cable.

Below are some symptoms of incorrectly installed floppy drives:

- Drive is not automatically detected
 - Check if the floppy controller is enabled under the BIOS settings
 - Verify there is only one floppy drive in the system
 - Verify that the floppy cable is installed correctly (i.e. using the connector with pin10~16 twisted)
 - Verify that the floppy drive is working properly (i.e. try a new drive)
- Drive Fail message at boot up
 - Verify with another drive or cable
- Drive does not power on
 - Check power cable and cabling
 - Check power supply
- Drive activity light is constantly on
 - Cable is on backwards

TIP: Pin 1 on the cable (usually designated by a colored wire) faces the drive's power connector.

2.27 – Finishing Up

Congratulations on making it this far! You're finished setting up the hardware aspect of your computer. Before closing up your chassis, make sure that all cables and wires are connected properly, especially IDE cables and jumpers. You may have difficulty powering on your system if the motherboard jumpers are not set correctly.

In the rare circumstance that you have experienced difficulty, you can find help by asking your vendor for assistance. If they are not available for assistance, please find setup information and documentation online at our website or by **calling your vendor's support line.**

Chapter 3: BIOS

3.0 – BIOS Setup Utility

With the BIOS setup utility, you can modify BIOS settings and control the special features of your computer. The setup utility uses a number of menus for making changes and turning the special features on or off.

NOTE

All menus are based on a typical system. The actual menus displayed on your screen may be different and depend on the hardware and features installed in your computer.

To start the BIOS setup utility:

- a. Turn on or reboot your system
- b. Press <F2> to start BIOS setup utility

BIOS Setup Utility				
Main	Advanced	Security	Power	Boot Exit
BIOS Version				1.00.xx
Enable ACPI				[Enabled]
Installed OS				[Win2000/XP]
Reset Configuration Data				[Yes]
System Time				[12:59:59]
System Date				[11/01/2002]
NumLock				[Enabled]
System Information				
Item Specific Help				
<Tab>, <Shift-Tab>, or <Enter> selects field				
F1 Help	. Select Item	-/+ Change Values		F9 Setup Defaults
ESC Exit	√ Select Menu	Enter Select	▶ Sub-Menu	F10 Save and Exit

To select an item

Use the left/right (↔) arrow keys to make a selection

To display a sub-menu (A pointer " ▶ " marks all sub menus)

Use the arrow keys to move the cursor to the sub menu you want. Then press <Enter>.

3.1 – BIOS Menu Bar

The menu bar at the top of the windows lists these selections:

Main	To configure basic system setups
Advanced	To configure the chipset features
Security	To configure user and supervisor passwords
Power	To configure power management features
Boot	To configure system boot order
Exit	To exit setup utility

NOTE

Options written in **bold type** represent the BIOS setup default

3.2 – BIOS Legend Bar

The chart describes the legend keys and their alternates:

Key	Function
<F1> or <Alt-H>	General help window
<ESC>	Exit current menu
√ arrow keys	Select a different menu
↑ or ↓ arrow keys	Move cursor up/down
<Tab> or <Shift - Tab>	Cycle cursor up/down
<Home> or <End>	Move cursor to top/bottom of the window
<PgUp> or <PgDn>	Move cursor to next/previous page
<F5> or <->	Select the previous value/setting of the field
<F6> or <+> or <Space>	Select the next value/setting of the field
<F9>	Load the default configuration values of the menu
<F10>	Save and exit
<Enter>	Execute command or select submenu
<Alt-R>	Refresh screen

3.3 – BIOS Main Menu

Main		Advanced		BIOS Setup Utility		Security		Power		Boot		Exit	
Item Specific Help													
BIOS Version		1.00.xx		<Tab>, <Shift-Tab>, or <Enter> selects field									
▶ Enable ACPI		[Yes]											
▶ Installed OS		[Win2000/XP]											
▶ Reset Configuration Data		[Yes]											
System Time		[12:59:59]											
System Date		[11/30/2002]											
System Information													
F1 Help		Select Item		-/+ Change Values		F9 Setup Defaults							
ESC Exit		Select Menu		Enter Select		▶ Sub-Menu		F10 Save and Exit					

3.3.1 – Enable ACPI Sub-Menu

Feature	Option	Description
Enable ACPI	Yes No	For operating systems that support the ACPI functionality Such as XP, 2K and ME

3.3.2 – Install OS Sub-Menu

Feature	Option	Description
Install OS	Other Win2000/XP	Select the OS you will use most often

3.3.3 – Reset Configuration Data Sub-Menu

Feature	Option	Description
Reset Configuration Data	Yes No	This setting erases all configuration data in a section of memory for ESCD (Extended System Configuration Data) which stores the configuration settings for non-PnP plug-in devices. Select Yes when required to restore the manufacturer's defaults

3.3.4 – System Time

Feature	Option	Description
HH : MM : SS	---	Set the system time

3.3.5 – System Date

Feature	Option	Description
MM : DD : YYYY	---	Set the system date

3.4 – BIOS Advanced Menu

BIOS Setup Utility				
Main	Advanced	Security	Power	Boot Exit
<ul style="list-style-type: none"> ▶ BIOS Event Log and Hardware Monitor ▶ Processors ▶ Chipset ▶ Floppy Disk Drive ▶ IDE Devices ▶ Integrated SCSI Controller ▶ Integrated Network Controller ▶ Integrated USB ▶ I/O Device Configuration ▶ Integrated Audio ▶ AGP slot ▶ PCI Device Slot 1 ▶ PCI Device Slot 2 ▶ PCI Device Slot 3 ▶ PCI Device Slot 4 ▶ PCI Device Slot 5 				Item Specific Help <Tab>, <Shift-Tab>, or <Enter> selects field
F1 Help	Select Item	-/+ Change Values	F9 Setup Defaults	
ESC Exit	Select Menu	Enter Select	▶ Sub-Menu	F10 Save and Exit

3.4.1 – Processors Sub-Menu

Feature	Option	Description
Hyper-Threading	Enabled Disabled	This setting determines whether the CPU Hyper-Threading is activated.

3.4.2 – Chipset Sub-Menu

Feature	Option	Description
Memory Remapping	Enabled Disabled	This setting determines whether the memory remapping is activated.

3.4.3 – Floppy Disk Drive Sub-Menu

Feature	Option	Description
Legacy Diskette A	360 KB 1.3 MB 720 KB 1.44/1.25 MB 2.88 MB	This setting selects the type of the floppy disk drive installed in system.
Floppy Disk Controller	Enabled Disabled Auto	This setting determines whether the floppy disk controller is activated.

3.4.4 – IDE Devices Sub-Menu

Feature	Option	Description
Primary/Secondary Master	Auto User ATAPI Removable CD-ROM None	Auto - To determine the IDE drive type by system BIOS User - To set IDE drive type by user ATAPI Removable - Read-and-write a media (e.g., LS120, USB floppy, USB ZIP) CD-ROM - Readable CD-ROM drive
Primary/Secondary Slave	Auto User ATAPI Removable CD-ROM None	
Local Bus IDE	Both Primary Secondary Disable	This setting determines whether the ICH4 primary and secondary IDE channels are activated.

3.4.5 – I/O Device Configuration Sub-Menu

Feature	Option	Description
Serial Port A	Enabled Disabled Auto	Enabled – To turn on the port It requires entering a base I/O address and an interrupt number Disabled – To turn off the port Auto – To let BIOS configure the port automatically during POST
Serial Port A Base I/O Address	3F8 2F8 3E8 2E8	
Serial Port A Interrupt	IRQ4 IRQ3	
Parallel Port	Enabled Disabled Auto	Enabled – To turn on the port It requires entering a base I/O address and an interrupt number Disabled – To turn off the port Auto – To let BIOS configure the port automatically during POST
Parallel Port Mode	ECP EPP Bi-directional Output Only	
Parallel Port Base I/O Address	378 278 3BC	
Parallel Port Interrupt	IRQ7 IRQ5	
Parallel Port DMA Channel	DMA3 DMA1	

3.4.6 – Integrated SCSI / Network / USB / Audio /1394 Controller Sub-Menu

Feature	Option	Description
Integrated PCI Device	Enabled Disabled	This setting determines whether the integrated PCI device is activated.
Option ROM Scan	Enabled Disabled	This setting determines whether the option ROM of the integrated PCI device is loaded during system BIOS POST.
Latency Timer	Default 0020h 0040h 0060h 0080h 00A0h 00C0h 00E0h	This setting controls how long each PCI device can hold the bus before another PCI device takes over. When set to higher values, every PCI device can conduct transactions for a longer time and thus improve the effective PCI bandwidth.

3.4.7 – AGP Slot Sub-Menu

Feature	Option	Description
Latency Timer	Default 0020h ? 00E0h	This setting controls how long each PCI device can hold the bus before another PCI device takes over. When set to higher values, every PCI device can conduct transactions for a longer time and thus improve the effective PCI bandwidth.
Graphic Aperture	256Mb 128Mb 64Mb 32Mb	This setting controls system RAM allocation. The aperture is a portion of the memory address range dedicated to graphics memory address space. Host cycles that hit the aperture range are forwarded to the AGP without any translation.

3.4.8 – PCI Device Slot- n Sub-Menu

Feature	Option	Description
Option ROM Scan	Enabled Disabled	This setting determines whether the option ROM of the PCI slot is loaded during system BIOS POST.
Latency Timer	Default 0020h ? 00E0h	This setting controls how long each PCI device can hold the bus before another PCI device takes over.

3.5 – BIOS Security Menu

BIOS Setup Utility				
Main	Advanced	Security	Power	Boot Exit
<ul style="list-style-type: none"> ▶ Set User Password ▶ Clear All Passwords ▶ Clear Supervisor Password ▶ Clear User Password 				Item Specific Help <Tab>, <Shift-Tab>, or <Enter> selects field
F1 Help	· Select Item	-/+ Change Values		F9 Setup Defaults
ESC Exit	√ Select Menu	Enter Select	▶ Sub-Menu	F10 Save and Exit

3.6 – BIOS Power Menu

BIOS Setup Utility				
Main	Advanced	Security	Power	Boot Exit
<ul style="list-style-type: none"> ▶ Remote Power-On ▶ After Power Failure 				Item Specific Help <Tab>, <Shift-Tab>, or <Enter> selects field
F1 Help	· Select Item	-/+ Change Values		F9 Setup Defaults
ESC Exit	√ Select Menu	Enter Select	▶ Sub-Menu	F10 Save and Exit

3.6.1 – Remote Power -On Sub-Menu

Feature	Option	Description
Remote Power-On	Enabled Disabled	Set to enable to have WOL (wake up on LAN) support

3.6.2 – After Power Failure Sub-Menu

Feature	Option	Description
After Power Failure	Stay Off Last State Power On	This setting specifies whether your system will reboot after a power failure or interrupt occurs. Set to stay off to leave the computer in the power off state. Set to last state to restore the system to the previous status before power failure or interrupt occurred. Set to power on to leave the computer in the power on state.

3.7 – BIOS Boot Menu

BIOS Setup Utility					
Main	Advanced	Security	Power	Boot	Exit
<ul style="list-style-type: none"> ▶ Quick Boot Mode ▶ Display Option ROM Message ▶ Default Primary Video Adapter ▶ Boot Device Priority 				Item Specific Help <Tab>, <Shift-Tab>, or <Enter> selects field	
F1 Help	· Select Item	-/+ Change Values		F9 Setup Defaults	
ESC Exit	√ Select Menu	Enter Select	▶ Sub-Menu	F10 Save and Exit	

3.7.1 – Quick Boot Mode Sub-Menu

Feature	Option	Description
Quick Boot Mode	Enabled Disabled	Set this option to enable for skipping some BIOS self test during POST

3.7.2 – Display Option ROM Message Sub-Menu

Feature	Option	Description
Display Option ROM Message	Enabled Disabled	Set this option to enabled for allowing system to display PCI devices' option ROMs during system boot up

3.7.3 – Default Primary Video Adapter Sub-Menu

Feature	Option	Description
Default Primary Video Adapter	AGP PCI	Set this option to control the system graphics device initialization priority. Set to AGP To make the system initialize the AGP card first. If the AGP card is not available, it will initialize the PCI card. Set to PCI To make the system initialize the PCI card first. If the PCI card is not available, it will initialize the AGP card

3.7.4 – Boot Device Priority Sub-Menu

The boot menu will list all bootable devices. Arrange the priorities of all bootable devices by using arrow keys and then pressing <Enter>.

3.8 – BIOS Exit Menu

BIOS Setup Utility			
Main	Advanced	Security	Power
<ul style="list-style-type: none"> ▶ Exit Saving Changes ▶ Exit Discarding Changes ▶ Load Setup Defaults ▶ Discard Changes ▶ Save Changes 			<p>Item Specific Help</p> <p><Tab>, <Shift-Tab>, or <Enter> selects field</p>
F1 Help	· Select Item	-/+ Change Values	F9 Setup Defaults
ESC Exit	√ Select Menu	Enter Select	▶ Sub-Menu F10 Save and Exit

3.8.1 – Exit Saving Changes

Use this option to exit setup utility and re-boot.
All new selections you have made are stored into CMOS.
System will use the new settings to boot up.

3.8.2 – Exit Discarding Changes

Use this option to exit setup utility and re-boot.
All new selections you have made are not stored into CMOS.
System will use the old settings to boot up.

3.8.3 – Load Setup Defaults

Use this option to load all default setup values.
Use this option when system CMOS values have been corrupted or modified incorrectly.

3.8.4 – Discard Changes

Use this option to restore all new setup values that you have made but not saved into CMOS.

3.8.5 – Save Changes

Use this option to store all new setup values into CMOS.

Chapter 4: Diagnostics

Note: if you experience problems with setting up your system, always check the following things in the following order:

CPU, Memory, Video

By checking these items, you will most likely find out what the problem might have been when setting up your system. For more information on troubleshooting, check the Tyan website at: <http://www.tyan.com>.

4.1 Beep Codes

Fatal errors which halt the boot process are communicated through a series of audible beeps.

- (1) Memory module initialization failed
 - (a) memory modules might not be plugged in pairs
 - (b) wrong type of memory
 - (c) bad memory modules
- (2) Graphics initialization failed

Before contacting your vendor or Tyan Technical Support, be sure that you note as much as you can about the beep code length and order that you experience. Also, be ready with information regarding add-in cards, drives and O/S to speed the support process and come to a quicker solution.

4.2 Flash Utility

Every BIOS file is unique for the motherboard it was designed for. For Flash Utilities, BIOS downloads, and information on how to properly use the Flash Utility with your motherboard, please check the Tyan web site: <http://www.tyan.com>

NOTE	Please be aware that by flashing your BIOS, you agree that in the event of a BIOS flash failure, you must contact your dealer for a replacement BIOS. There are no exceptions. Tyan does not have a policy for replacing BIOS chips directly with end users. In no event will Tyan be held responsible for damages done by the end user.
-------------	--

Appendix I: Glossary

ACPI (Advanced Configuration and Power Interface): a power management specification that allows the operating system to control the amount of power distributed to the computer's devices. Devices not in use can be turned off, reducing unnecessary power expenditure.

AGP (Accelerated Graphics Port): a PCI-based interface which was designed specifically for demands of 3D graphics applications. The 32-bit AGP channel directly links the graphics controller to the main memory. While the channel runs only at 66 MHz, it supports data transmission during both the rising and falling ends of the clock cycle, yielding an effective speed of 133 MHz.

ATAPI (AT Attachment Packet Interface): also known as IDE or ATA; a drive implementation that includes the disk controller on the device itself. It allows CD-ROMs and tape drives to be configured as master or slave devices, just like HDDs.

ATX: the form factor designed to replace the AT form factor. It improves on the AT design by rotating the board 90 degrees, so that the IDE connectors are closer to the drive bays, and the CPU is closer to the power supply and cooling fan. The keyboard, mouse, USB, serial, and parallel ports are built-in.

Bandwidth: refers to carrying capacity. The greater the bandwidth, the more data the bus, phone line, or other electrical path can carry. Greater bandwidth results in greater speed.

BBS (BIOS Boot Specification): a feature within the BIOS that creates, prioritizes, and maintains a list of all Initial Program Load (IPL) devices, and then stores that list in NVRAM. IPL devices have the ability to load and execute an OS, as well as provide the ability to return to the BIOS if the OS load process fails. At that point, the next IPL device is called upon to attempt loading of the OS.

BIOS (Basic Input/Output System): the program that resides in the ROM chip, which provides the basic instructions for controlling your computer's hardware. Both the operating system and application software use BIOS routines to ensure compatibility.

Buffer: a portion of RAM which is used to temporarily store data; usually from an application though it is also used when printing and in most keyboard drivers. The CPU can manipulate data in a buffer before copying it to a disk drive. While this improves system performance (reading to or writing from a disk drive a single time is much faster than doing so repeatedly) there is the possibility of losing your data should the system crash. Information in a buffer is temporarily stored, not permanently saved.

Bus: a data pathway. The term is used especially to refer to the connection between the processor and system memory, and between the processor and PCI or ISA local buses.

Bus mastering: allows peripheral devices and IDEs to access the system memory without going through the CPU (similar to DMA channels).

Cache: a temporary storage area for data that will be needed often by an application. Using a cache lowers data access times since the information is stored in SRAM instead of slower DRAM. Note that the cache is also much smaller than your regular memory: a typical cache size is 512KB, while you may have as much as 4GB of regular memory.

Closed and open jumpers: jumpers and jumper pins are active when they are “on” or “closed”, and inactive when they are “off” or “open”.

CMOS (Complementary Metal-Oxide Semiconductors): chips that hold the basic startup information for the BIOS.

COM port: another name for the serial port, which is called as such because it transmits the eight bits of a byte of data along one wire, and receives data on another single wire (that is, the data is transmitted in serial form, one bit after another). Parallel ports transmit the bits of a byte on eight different wires at the same time (that is, in parallel form, eight bits at the same time).

DDR (Double Data Rate): a technology designed to double the clock speed of the memory. It activates output on both the rising and falling edge of the system clock rather than on just the rising edge, potentially doubling output.

DIMM (Dual In-line Memory Module): faster and more capacious form of RAM than SIMMs, and do not need to be installed in pairs.

DIMM bank: sometimes called DIMM socket because the physical slot and the logical unit are the same. That is, one DIMM module fits into one DIMM socket, which is capable of acting as a memory bank.

DMA (Direct Memory Access): channels that are similar to IRQs. DMA channels allow hardware devices (like soundcards or keyboards) to access the main memory without involving the CPU. This frees up CPU resources for other tasks. As with IRQs, it is vital that you do not double up devices on a single line. Plug -n-Play devices will take care of this for you.

DRAM (Dynamic RAM): widely available, very affordable form of RAM which loses data if it is not recharged regularly (every few milliseconds). This refresh requirement makes DRAM three to ten times slower than non-recharged RAM such as SRAM.

ECC (Error Correction Code or Error Checking and Correcting): allows data to be checked for errors during run-time. Errors can subsequently be corrected at the same time that they're found.

EEPROM (Electrically Erasable Programmable ROM): also called Flash BIOS, it is a ROM chip which can, unlike normal ROM, be updated. This allows you to keep up with changes in the BIOS programs without having to buy a new chip. TYAN's BIOS updates can be found at <http://www.tyan.com>

ESCD (Extended System Configuration Data): a format for storing information about Plug-n-Play devices in the system BIOS. This information helps properly configure the system each time it boots.

Firmware: low-level software that controls the system hardware.

Form factor: an industry term for the size, shape, power supply type, and external connector type of the Personal Computer Board (PCB) or motherboard. The standard form factors are the AT and ATX.

Global timer: onboard hardware timer, such as the Real-Time Clock (RTC).

HDD: stands for Hard Disk Drive, a type of fixed drive.

H-SYNC: controls the horizontal synchronization/properties of the monitor.

IC (Integrated Circuit): the formal name for the computer chip.

IDE (Integrated Device/Drive Electronics): a simple, self-contained HDD interface. It can handle drives up to 8.4 GB in size. Almost all IDEs sold now are in fact Enhanced IDEs (EIDEs), with maximum capacity determined by the hardware controller.

IDE INT (IDE Interrupt): a hardware interrupt signal that goes to the IDE.

I/O (Input/Output): the connection between your computer and another piece of hardware (mouse, keyboard, etc.)

IRQ (Interrupt Request): an electronic request that runs from a hardware device to the CPU. The interrupt controller assigns priorities to incoming requests and delivers them to the CPU. It is important that there is only one device hooked up to each IRQ line; doubling up devices on IRQ lines can lock up your system. Plug-n-Play operating systems can take care of these details for you.

Latency: the amount of time that one part of a system spends waiting for another part to catch up. This occurs most commonly when the system sends data out to a peripheral device and has to wait for the peripheral to spread (peripherals tend to be slower than onboard system components).

NVRAM: ROM and EEPROM are both examples of Non-Volatile RAM, memory that holds its data without power. DRAM, in contrast, is volatile.

Parallel port: transmits the bits of a byte on eight different wires at the same time.

PCI (Peripheral Component Interconnect): a 32 or 64-bit local bus (data pathway) which is faster than the ISA bus. Local buses are those which operate within a single system (as opposed to a network bus, which connects multiple systems).

PCI PIO (PCI Programmable Input/Output) modes: the data transfer modes used by IDE drives. These modes use the CPU for data transfer (in contrast, DMA channels do not). PCI refers to the type of bus used by these modes to communicate with the CPU.

PCI-to-PCI bridge: allows you to connect multiple PCI devices onto one PCI slot.

Pipeline burst SRAM: a fast secondary cache. It is used as a secondary cache because SRAM is slower than SDRAM, but usually larger. Data is cached first to the faster primary cache, and then, when the primary cache is full, to the slower secondary cache.

PnP (Plug-n-Play): a design standard that has become ascendant in the industry. Plug-n-Play devices require little set-up to use. Devices and operating systems that are not Plug-n-Play require you to reconfigure your system each time you add or change any part of your hardware.

PXE (Preboot Execution Environment): one of four components that together make up the Wired for Management 2.0 baseline specification. PXE was designed to define a standard set of preboot protocol services within a client with the goal of allowing networked-based booting to boot using industry standard protocols.

RAID (Redundant Array of Independent Disks): a way for the same data to be stored in different places on many hard drives. By using this method, the data is stored redundantly and multiple hard drives will appear as a single drive to the operating system. RAID level 0 is known as striping, where data is striped (or overlapped) across multiple hard drives, but offers no fault-tolerance. RAID level 1 is known as mirroring, which stores the data within at least two hard drives, but does not stripe. RAID level 1 also allows for faster access time and fault-tolerance, since either hard drive can be read at the same time. RAID level 0+1 is both striping and mirroring, providing fault-tolerance, striping, and faster access all at the same time.

RAIDIOS: RAID I/O Steering (Intel)

RAM (Random Access Memory): technically refers to a type of memory where any byte can be accessed without touching the adjacent data and is often referred to the system's main memory. This memory is available to any program running on the computer.

ROM (Read-Only Memory): a storage chip which contains the BIOS; the basic instructions required to boot the computer and start up the operating system.

SDRAM (Synchronous Dynamic RAM): called as such because it can keep two sets of memory addresses open simultaneously. By transferring data alternately from one set of addresses and then the other, SDRAM cuts down on the delays associated with non-synchronous RAM, which must close one address bank before opening the next.

Serial port: called as such because it transmits the eight bits of a byte of data along one wire, and receives data on another single wire (that is, the data is transmitted in serial form, one bit after another).

SCSI Interrupt Steering Logic (SISL): Architecture that allows a RAID controller, such as AcceleRAID 150, 200 or 250, to implement RAID on a system board-embedded SCSI bus or a set of SCSI busses. SISL: SCSI Interrupt Steering Logic (LSI) (only on LSI SCSI boards)

Sleep/Suspend mode: in this mode, all devices except the CPU shut down.

SDRAM (Static RAM): unlike DRAM, this type of RAM does not need to be refreshed in order to prevent data loss. Thus, it is faster and more expensive.

Standby mode: in this mode, the video and hard drives shut down; all other devices continue to operate normally.

UltraDMA-33/66/100: a fast version of the old DMA channel. UltraDMA is also called UltraATA. Without a proper UltraDMA controller, your system cannot take advantage of higher data transfer rates of the new UltraDMA/UltraATA hard drives.

USB (Universal Serial Bus): a versatile port. This one port type can function as a serial, parallel, mouse, keyboard or joystick port. It is fast enough to support video transfer, and is capable of supporting up to 127 daisy-chained peripheral devices.

VGA (Video Graphics Array): the PC video display standard

V-SYNC: controls the vertical scanning properties of the monitor.

ZCR (Zero Channel RAID): PCI card that allows a RAID card to use the onboard SCSI chip, thus lowering cost of RAID solution

ZIF Socket (Zero Insertion Force socket): these sockets make it possible to insert CPUs without damaging the sensitive CPU pins. The CPU is lightly placed in an open ZIF socket, and a lever is pulled down. This shifts the processor over and down, guiding it into the board and locking it into place.

Technical Support

If a problem arises with your system, you should turn to your dealer for help first. Your system has most likely been configured by them, and they should have the best idea of what hardware and software your system contains. Furthermore, if you purchased your system from a dealer near you, you can bring your system to them to have it serviced instead of attempting to do so yourself (which can have expensive consequences).

Help Resources:

1. See the beep codes section of this manual.
2. See the TYAN website for FAQ 's, bulletins, driver updates, and other information: <http://www.tyan.com>
3. Contact your dealer for help BEFORE calling TYAN.
4. Check the TYAN user group: alt.comp.periphs.mainboard.TYAN

Returning Merchandise for Service

During the warranty period, contact your distributor or system vendor FIRST for any product problems. This warranty only covers normal customer use and does not cover damages incurred during shipping or failure due to the alteration, misuse, abuse, or improper maintenance of products.

NOTE: A receipt or copy of your invoice marked with the date of purchase is required before any warranty service can be rendered. You may obtain service by calling the manufacturer for a Return Merchandise Authorization (RMA) number. The RMA number should be prominently displayed on the outside of the shipping carton and the package should be mailed prepaid. TYAN will pay to have the board shipped back to you.

**Notice for the USA**

Compliance Information Statement (Declaration of Conformity Procedure) DoC
FCC Part 15: This device complies with part 15 of the FCC Rules

Operation is subject to the following conditions:

- 1) This device may not cause harmful interference, and
- 2) This device must accept any interference received including interference that may cause undesired operation. If this equipment does cause harmful interference to radio or television reception, which can be determined by turning the equipment off and on, the user is encouraged to try one or more of the following measures:
 - Reorient or relocate the receiving antenna.
 - Increase the separation between the equipment and the receiver.
 - Plug the equipment into an outlet on a circuit different from that of the receiver.
 - Consult the dealer on an experienced radio/television technician for help.

Notice for Canada

This apparatus complies with the Class B limits for radio interference as specified in the Canadian Department of Communications Radio Interference Regulations. (Cet appareil est conforme aux normes de Classe B d'interference radio tel q ue specifie par le Ministere Canadien des Communications dans les reglements d'ineteference radio.)

**Notice for Europe (CE Mark)**

This product is in conformity with the Council Directive 89/336/EEC, 92/31/EEC (EMC).

CAUTION: Lithium battery included with this board. Do not puncture, mutilate, or dispose of battery in fire. Danger of explosion if battery is incorrectly replaced. Replace only with the same or equivalent type recommended by manufacturer. Dispose of used battery according to manufacturer instructions and in accordance with your local regulations.

Document #: D1491 - 100