



GE Pro-M / GE Pro-HT

# User Manual

Version 1.0

Published December 2002

Copyright©2002 ASRock INC. All rights reserved.

---

## Copyright Notice:

No part of this manual may be reproduced, transcribed, transmitted, or translated in any language, in any form or by any means, except duplication of documentation by the purchaser for backup purpose, without written consent of ASRock Inc.

Products and corporate names appearing in this manual may or may not be registered trademarks or copyrights of their respective companies, and are used only for identification or explanation and to the owners' benefit, without intent to infringe.

## Disclaimer:

Specifications and information contained in this manual are furnished for informational use only and subject to change without notice, and should not be constructed as a commitment by ASRock. ASRock assumes no responsibility for any errors or omissions that may appear in this manual.

With respect to the contents of this manual, ASRock does not provide warranty of any kind, either expressed or implied, including but not limited to the implied warranties or conditions of merchantability or fitness for a particular purpose.

In no event shall ASRock, its directors, officers, employees, or agents be liable for any indirect, special, incidental, or consequential damages (including damages for loss of profits, loss of business, loss of data, interruption of business and the like), even if ASRock has been advised of the possibility of such damages arising from any defect or error in the manual or product.

**ASRock Website: <http://www.asrock.com>**

---

# Contents

<b>1</b>	<b>Introduction</b>	<b>4</b>
1.1	Package Contents	4
1.2	Specifications	4
1.3	Motherboard Layout (GE Pro-M)	6
1.4	Motherboard Layout (GE Pro-HT)	7
1.5	ASRock I/O™ (GE Pro-M / GE Pro-HT)	8
<b>2</b>	<b>Installation</b>	<b>9</b>
2.1	Screw Holes	9
2.2	Pre-installation Precautions	9
2.3	CPU Installation	9
2.4	Installation of Heatsink and CPU fan	10
2.5	Installation of Memory Modules (DIMM)	10
2.6	Expansion Slots	11
2.7	Jumpers Setup	12
2.8	Connectors	12
<b>3</b>	<b>BIOS Setup</b>	<b>15</b>
3.1	BIOS Setup Utility	15
3.1.1	BIOS Menu Bar	15
3.1.2	Legend Bar	15
3.2	Main Menu	16
3.3	Advanced, Security, Power, Boot, and Exit Menus	18
<b>4</b>	<b>Software Support</b>	<b>19</b>
4.1	Installing Operating System	19
4.2	Support CD Information	19
4.2.1	Running Support CD	19
4.2.2	Drivers Menu	19
4.2.3	Utilities Menu	19
4.2.4	ASRock PC-DIY Live Demo Program	19
4.2.5	Contact Information	19
	<b>Appendix: Advanced BIOS Setup</b>	<b>20</b>
1.	Advanced Menu	20
2.	Security Menu	23
3.	Power Menu	24
4.	Boot Menu	25
5.	Exit Menu	25

---

# Chapter 1 Introduction

Thank you for purchasing ASRock GE Pro-M / GE Pro-HT motherboard, a reliable motherboard produced under ASRock's consistently stringent quality control. It delivers excellent performance with robust design conforming to ASRock's commitment to quality and endurance.

Chapter 1 and 2 of this manual contain introduction of the motherboard and step-by-step installation guide for new DIY system builders. Chapter 3 and 4 contain basic BIOS setup and Support CD information.

For advanced users' reference, the Appendix appearing on page 20 offers more advanced BIOS setup information.

## 1.1 Package Contents

ASRock GE Pro-M or GE Pro-HT motherboard

(Micro ATX form factor: 9.6" x 9.6", 24.4 x 24.4 cm)

ASRock GE Pro-M / GE Pro-HT Quick Installation Guide

ASRock Intel-SiS Support CD

1 cable for IDE devices (1 x ATA 66/100/133)

1 cable for floppy drive (1 x ribbon cable)

1 ASRock I/O shield

1 COM port bracket

## 1.2 Specifications

**Platform:** Micro ATX form factor (9.6" x 9.6", 24.4 x 24.4 cm)

**CPU:** Socket 478 for Intel® Pentium® 4 / Celeron® processor

**Chipsets:** North Bridge on GE Pro-M motherboard: SiS 651 chipsets, standard FSB 533 MHz

North Bridge on GE Pro-HT motherboard: SiS 651<sup>HT</sup> chipsets , standard FSB 533 MHz, supports Hyper-Threading Technology (see **CAUTION1**);

South Bridge: Supports USB 2.0, ATA 133

**Clock Generator:** 100 MHz - 200MHz

**Memory:** 2 slots for DDR: DIMM1 and DIMM2 (PC1600/PC2100/ PC2700), Max. 2GB

2 slots for SDR: DIMM3 and DIMM4 (PC100/ PC133), Max. 2GB

**IDE:** IDE1: ATA 133 / Ultra DMA Mode 6; IDE2: ATA 133 / Ultra DMA Mode 6  
Can connect up to 4 IDE devices

**Floppy Port:** Supports floppy disk drive

**Audio:** 5.1 channels AC'97 Audio

**LAN:** Speed: 802.3u (10/100 Ethernet), supports Wake-On-LAN

---

**Hardware Monitor:** CPU temperature sensing (ASRock U-COP);  
CPU overheat shutdown to protect CPU life (ASRock U-COP)  
(see **CAUTION 2**); Chassis temperature sensing;  
Voltage monitoring: +12V, +5V, +3V, Vcore;  
CPU fan tachometer; Chassis fan tachometer

**PCI slots:** 3 slots with PCI Specification 2.2

**AGP slot:** 1 universal AGP slot, supports 3.3v / 1.5v, 4X / 2X / 1X AGP card

**AMR slot:** 1 slot, supports ASRock MR modem card

**USB 2.0:** 4 default USB 2.0 ports and one extra set of header for 2 additional  
USB 2.0 ports upgrade (see **CAUTION 3**)

**ASRock I/O™:** PS/2: 1 keyboard port / 1 mouse port;  
1 RJ 45 port;  
4 rear default USB 2.0 ports;  
1 VGA port; 1 parallel port: ECP/EPP support  
Audio Jack: Line Out/ Line In/ Microphone + Game port

**BIOS:** AMI legal BIOS; Supports "Plug and Play";  
ACPI 1.1 compliance wake up events;  
Supports jumperfree; SMBIOS 2.3.1 support;  
CPU frequency stepless control  
(only for advanced users' reference, see **CAUTION 4**)

**OS:** Microsoft® Windows® 98 SE / ME / 2000 / XP compliant

### **CAUTION!**

1. About the setting of "Hyper-Threading Technology", please check page 20.
2. While CPU overheat is detected, the system will automatically shutdown. Please check if the CPU fan on the motherboard functions properly before you resume the system. To improve heat dissipation, remember to spray thermal grease between the CPU and the heatsink when you install the PC system.
3. Power Management for USB 2.0 works fine under Microsoft® Windows® XP. It may not work properly under Microsoft® Windows® 98/ME/2000. Please refer to Microsoft® official document at <http://www.microsoft.com/HWDEV/BUS/usb/USB2support.asp>
4. Although GE Pro-M/GE Pro-HT offers stepless control, it is not recommended to perform over clocking. Frequencies other than the recommended CPU bus frequency may cause the instability of the system or damage the CPU.

### 1.3 Motherboard Layout (GE Pro-M)

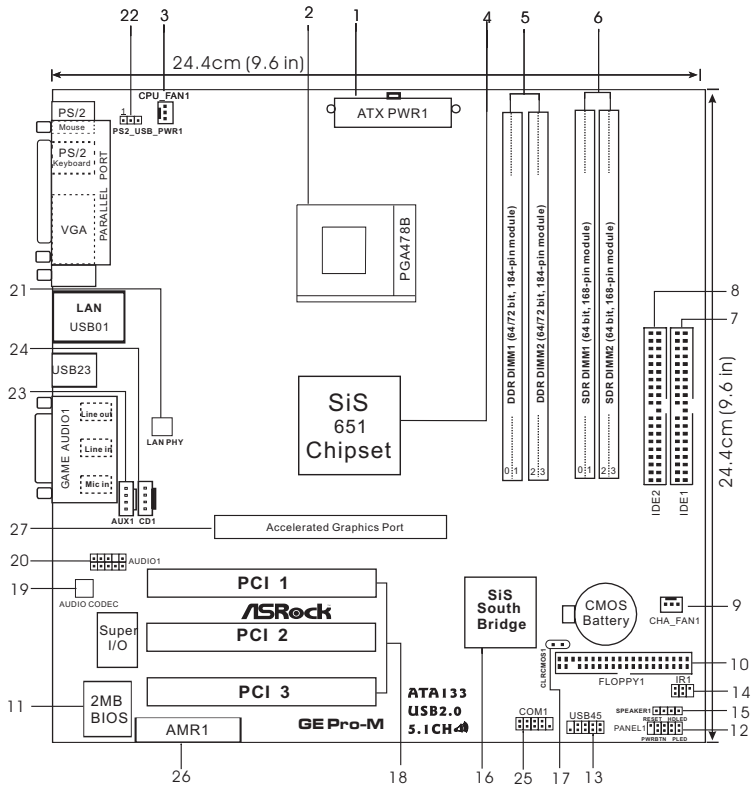

- |    |  |    |  |
|----|--|----|--|
| 1  | ATX power connector (ATXPWR1)            | 15 | Chassis speaker connector (SPEAKER1)   |
| 2  | CPU socket                               | 16 | South Bridge controller                |
| 3  | CPU fan connector (CPU_FAN1)             | 17 | Clear CMOS (CLR CMOS1)                 |
| 4  | North Bridge controller                  | 18 | PCI slots (PCI 1-3)                    |
| 5  | 184-pin DDR DIMM slots (DDR1-2, Blue)    | 19 | AUDIO CODEC                            |
| 6  | 168-pin SDRAM DIMM slots (SDR1-2, Black) | 20 | Front panel audio connector (AUDIO1)   |
| 7  | Primary IDE connector (IDE1, Blue)       | 21 | LAN PHY                                |
| 8  | Secondary IDE connector (IDE2, Black)    | 22 | PS2_USB_PWR1 jumper                    |
| 9  | Chassis fan connector (CHA_FAN1)         | 23 | Internal audio connector: AUX1 (white) |
| 10 | Floppy connector (FLOPPY1)               | 24 | Internal audio connector: CD1 (black)  |
| 11 | Flash Memory                             | 25 | Serial port connector (COM1)           |
| 12 | System panel connector (PANEL1)          | 26 | AMR slot                               |
| 13 | USB 2.0 header (USB45)                   | 27 | AGP slot                               |
| 14 | Infrared module connector (IR1)          |    |  |

# 1.4 Motherboard Layout (GE Pro-HT)

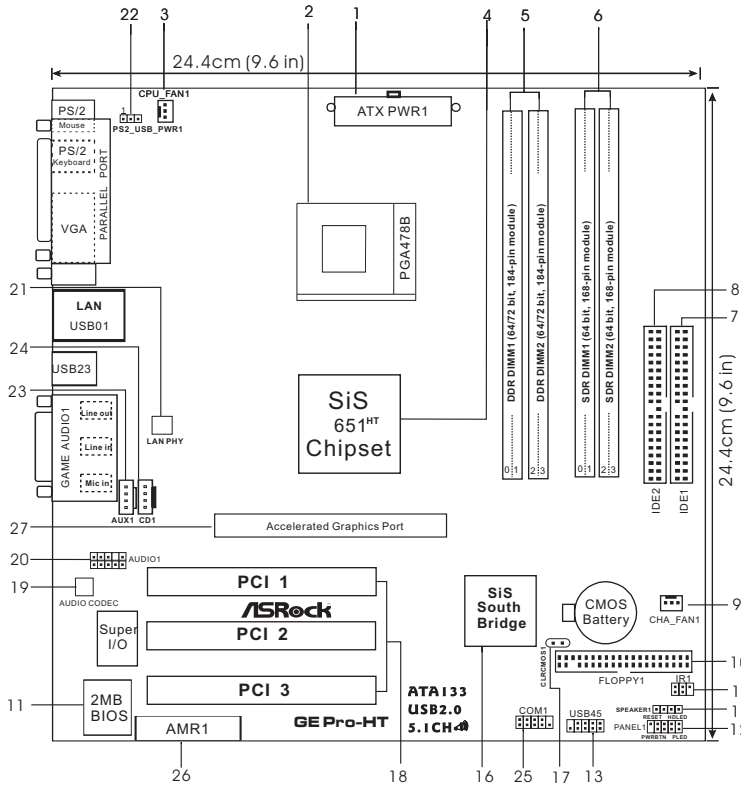

- |    |  |    |  |
|----|--|----|--|
| 1  | ATX power connector (ATXPWR1)            | 15 | Chassis speaker connector (SPEAKER1)   |
| 2  | CPU socket                               | 16 | South Bridge controller                |
| 3  | CPU fan connector (CPU_FAN1)             | 17 | Clear CMOS (CLR CMOS1)                 |
| 4  | North Bridge controller                  | 18 | PCI slots (PCI 1-3)                    |
| 5  | 184-pin DDR DIMM slots (DDR1-2, Blue)    | 19 | AUDIO CODEC                            |
| 6  | 168-pin SDRAM DIMM slots (SDR1-2, Black) | 20 | Front panel audio connector (AUDIO1)   |
| 7  | Primary IDE connector (IDE1, Blue)       | 21 | LAN PHY                                |
| 8  | Secondary IDE connector (IDE2, Black)    | 22 | PS2_USB_PWR1 jumper                    |
| 9  | Chassis fan connector (CHA_FAN1)         | 23 | Internal audio connector: AUX1 (white) |
| 10 | Floppy connector (FLOPPY1)               | 24 | Internal audio connector: CD1 (black)  |
| 11 | Flash Memory                             | 25 | Serial port connector (COM1)           |
| 12 | System panel connector (PANEL1)          | 26 | AMR slot                               |
| 13 | USB 2.0 header (USB45)                   | 27 | AGP slot                               |
| 14 | Infrared module connector (IR1)          |    |  |

---

## 1.5 ASRock I/O™ (GE Pro-M / GE Pro-HT)

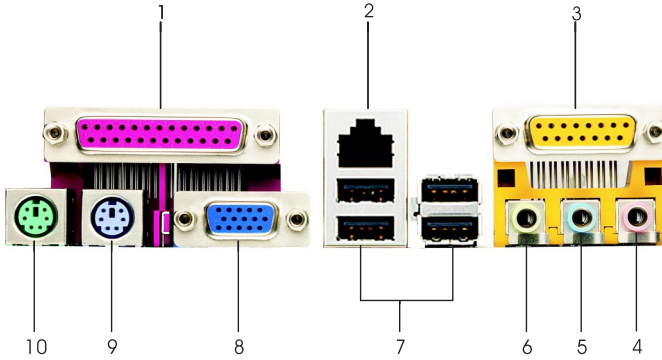

- |   |                      |    |                             |
|---|----------------------|----|-----------------------------|
| 1 | Parallel port        | 6  | Line Out (Lime)             |
| 2 | RJ-45 port           | 7  | USB 2.0 ports               |
| 3 | Game port            | 8  | VGA port                    |
| 4 | Microphone (Pink)    | 9  | PS/2 keyboard port (Purple) |
| 5 | Line In (Light Blue) | 10 | PS/2 mouse port (Green)     |



---

## Chapter 2 Installation

GE Pro-M / GE Pro-HT is a Micro ATX form factor (9.6" x 9.6", 24.4 x 24.4 cm) motherboard. Before you install the motherboard, study the configuration of your chassis to ensure that the motherboard fits into it.



Make sure to unplug the power cord before installing or removing the motherboard. Failure to do so may cause physical injuries to you and damages to motherboard components.

### 2.1 Screw Holes

Place screws into the holes indicated by circles to secure the motherboard to the chassis.



Do not over-tighten the screws! Doing so may damage the motherboard.

### 2.2 Pre-installation Precautions

Take note of the following precautions before you install motherboard components or change any motherboard settings.

1. Unplug the power cord from the wall socket before touching any component.
2. To avoid damaging the motherboard components due to static electricity, NEVER place your motherboard directly on the carpet or the like. Also remember to use a grounded wrist strap or touch a safety grounded object before you handle components.
3. Hold components by the edges and do not touch the ICs.
4. Whenever you uninstall any component, place it on a grounded antistatic pad or in the bag that comes with the component.

**Before you install or remove any component, ensure that the power is switched off or the power cord is detached from the power supply.**

Failure to do so may cause severe damage to the motherboard, peripherals, and/or components.

### 2.3 CPU Installation

- Step 1. Unlock the socket by lifting the lever up to a 90° angle.
- Step 2. Position the CPU directly above the socket such that its marked corner matches the base of the socket lever.
- Step 3. Carefully insert the CPU into the socket until it fits in place.



The CPU fits only in one correct orientation. DO NOT force the CPU into the socket to avoid bending of the pins.

Step 4. When the CPU is in place, press it firmly on the socket while you push down the socket lever to secure the CPU. The lever clicks on the side tab to indicate that it is locked.

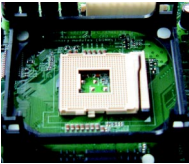

Step 1



Step 2, 3

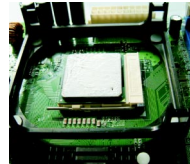

Step 4

## 2.4 Installation of CPU Fan and Heatsink

Intel® Pentium® 4 CPU requires larger heatsink and cooling fan. Thermal grease between the CPU and the heatsink is also needed to improve heat transfer. Make sure that the CPU and the heatsink are securely fastened and in good contact with each other. For proper installation, please kindly refer to the instruction manuals of vendors of CPU fan and heatsink.

## 2.5 Installation of Memory Modules (DIMM)

SDRAM (Synchronous DRAM) DIMM (Dual In-line Memory Module) has 168 pins and DDR (Double Data Rate) SDRAM DIMM has 184 pins.



Please make sure to disconnect power supply before adding or removing DIMMs or the system components.



168-pin RAM



184-pin RAM

The 168-pin SDRAM DIMM slot (black) and 184-pin DDR DIMM slot (blue) can be easily distinguished by the fool-proof design.



Please do not use both 168-pin SDRAM DIMM and 184-pin DDR DIMM at the same time. To optimize the compatibility, it is not recommended to use two different models of the DIMMs at the same time.

- 
- Step 1. Unlock a DIMM slot by pressing the retaining clips outward.
  - Step 2. Align a DIMM on the slot such that the notch on the DIMM matches the break on the slot.
  - Step 3. Firmly insert the DIMM into the slot until the retaining clip snap back in place and the DIMM is properly seated.

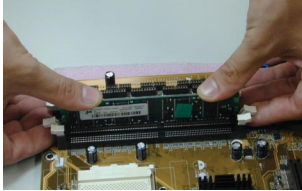

## 2.6 Expansion Slots (PCI, AMR, and AGP Slots)

There are 3 PCI slots, 1 AMR slot, and 1 AGP slot on both GE Pro-M and GE Pro-HT motherboards.

**PCI slots:** PCI slots are used to install expansion cards that have the 32-bit PCI interface.

**AMR slot:** AMR slot is used to insert ASRock MR card with v.92 Modem functionality.

**AGP slot:** The AGP slot is used to install a graphics card.

**The ASRock AGP slot has a special locking mechanism which can securely fasten the graphics card inserted.**



### Installing an expansion card

- Step 1. Before installing the expansion card, read the documentation of the expansion card and make necessary hardware settings for the card.
- Step 2. Remove the system unit cover (if your motherboard is already installed in a chassis).
- Step 3. Remove the bracket facing the slot that you intend to use. Keep the screw for later use.
- Step 4. Align the card connector with the slot and press firmly until the card is completely seated on the slot.
- Step 5. Fasten the card to the chassis with screws.
- Step 6. Replace the system cover.

## 2.7 Jumpers Setup

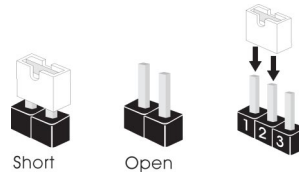
The illustration shows how jumpers are setup. When the jumper cap is placed on pins, the jumper is “SHORT”. If no jumper cap is placed on pins, the jumper is “OPEN”. The illustration shows a 3-pin jumper whose pin1 and pin2 are “SHORT” when jumper cap is placed on these 2 pins.



Jumper	Setting	Description
PS2_USB_PWR1 (see p.6/p.7 item 22)	<div style="display: flex; justify-content: space-around;"> <div style="text-align: center;"> <p>1_2</p>  <p>+5V</p> </div> <div style="text-align: center;"> <p>2_3</p>  <p>+5VSB</p> </div> </div>	Short pin2, pin3 to enable +5VSB (standby) for PS/2 or USB wake up events.

Note: To select +5VSB, it requires 2 Amp and higher standby current provided by power supply.

### Clear CMOS

CLRCMOS1  
(see p.6/p.7 item 17)



### Description



To clear and reset the system parameters to default setup, please turn off the computer and unplug the power cord, then short the solder points for more than 3 seconds by using metal material, e.g., a paper clip.

Note: These solder points allow you to clear the data in CMOS. The data in CMOS includes system setup information such as system password, date, time, and system setup parameters.

## 2.8 Connectors

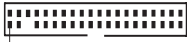

Connectors are NOT jumpers. DO NOT place jumper caps over these connectors.

Connector	Figure	Description
FDD connector (33-pin FLOPPY1) (see p.6/p.7 item 10)		 <p>Red marking</p>

Note: Match the red marking on the floppy ribbon cable with Pin1.

Primary IDE connector (Blue)  
(39-pin IDE1)  
(see p.6/p.7 item 7)



Secondary IDE connector (Black)  
(39-pin IDE2)  
(see p.6/p.7 item 8)



80-Pin ATA 100/133 cable

**Note:** To optimize compatibility and performance, please connect your hard disk drive to the primary IDE connector (IDE1, blue) and CD-ROM to the secondary IDE connector (IDE2, black).

USB header  
(9-pin USB45)  
(see p.6/p.7 item 13)

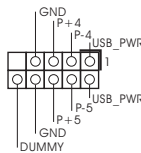

ASRock I/O™ already provided 4 default USB ports. If the 4-USB ports on the rear panel are not sufficient, this USB header is available for 2 additional USB ports.

Infrared module connector  
(5-pin IR1)  
(see p.6/p.7 item 14)

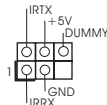

This connector supports an optional wireless transmitting and receiving infrared module.

Internal audio connectors  
(4-pin CD1, 4-pin AUX1)  
(CD1: see p.6/p.7 item 24)  
(AUX1: see p.6/p.7 item 23)



These connectors allow you to receive stereo audio input from sound sources such as a CD-ROM, DVD-ROM, TV tuner card, or MPEG card.

Front panel audio connector  
(9-pin AUDIO1)  
(see p.6/p.7 item 20)

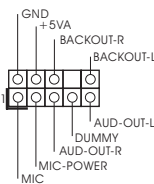

This is an interface for front panel audio cable that allows convenient connection and control of audio devices.

System panel connector  
(9-pin PANEL1)  
(see p.6/p.7 item 12)

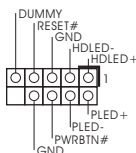

This connector accommodates several system front panel functions.

---

Chassis speaker connector  
(4-pin SPEAKER 1)  
(see p.6/p.7 item 15)

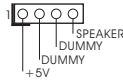

This connector allows you to attach to the chassis speaker.

---

Chassis fan connector  
(3-pin CHA\_FAN1)  
(see p.6/p.7 item 9)

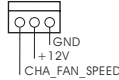

Connect the fan cable to the connector matching the black wire to the ground pin.

---

CPU fan connector  
(3-pin CPU\_FAN1)  
(see p.6/p.7 item 3)

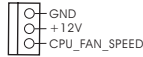

Connect the fan cable to the connector matching the black wire to the ground pin.

---

ATX power connector  
(20-pin ATXPWR1)  
(see p.6/p.7 item 1)



Connect an ATX power supply to the connector.

---

COM1 connector  
(9-pin COM1)  
(see p.6/p.7 item 25)

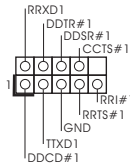

This connector supports a serial port module.

---

# Chapter 3 BIOS Setup

## 3.1 BIOS Setup Utility

This section explains how to configure your system using the BIOS Setup Utility. The Flash Memory on the motherboard stores the BIOS Setup Utility. When you start up the computer, there is a chance for you to run the BIOS Setup. Press <F2> during the Power-On-Self-Test (POST) to enter the BIOS Setup Utility, otherwise, POST continues with its test routines.

If you wish to enter the BIOS Setup after POST, restart the system by pressing <Ctl> + <Alt> + <Delete>, or by pressing the reset button on the system chassis. You can also restart by turning the system off and then back on.

The BIOS Setup Utility is designed to be user-friendly. It is a menu-driven program, which allows you to scroll through its various sub-menus and select among the predetermined choices.



Because the BIOS software is constantly being updated, the following BIOS setup screens and descriptions are for reference purpose only, and may not exactly match what you see on your screen.

### 3.1.1 BIOS Menu Bar

The top of the screen has a menu bar with the following selections:

<b>MAIN</b>	Sets up the basic system configuration
<b>ADVANCED</b>	Sets up the advanced features
<b>SECURITY</b>	Sets up the security features
<b>POWER</b>	Configures Power Management features
<b>BOOT</b>	Configures the default system device that is used to locate and load the Operating System
<b>EXIT</b>	Exits the current menu or the BIOS Setup

To access the menu bar items, press the right or left arrow key on the keyboard until the desired item is highlighted.

### 3.1.2 Legend Bar

At the bottom of the Setup Screen is a legend bar. The following table lists the keys in the legend bar with their corresponding functions.

Navigation Key(s)	Function Description
<F1>	Displays the General Help Screen
<ESC>	Jumps to the Exit menu or returns to the upper menu from the current menu
↑ / ↓	Moves cursor up or down between fields
← / →	Selects menu to the left or right
+ / -	Increases or decreases values
<Enter>	Brings up a selected menu for a highlighted field
<F9>	Resets the current screen to its Setup Defaults
<F10>	Saves changes and exits Setup

## 3.2 Main Menu

When you enter the BIOS Setup Utility, the following screen appears.

AMIBIOS SETUP UTILITY - VERSION 3.31a			
Main	Advanced	Security	Power Boot Exit
System Date <b>Dec</b> 18 2002 Tue		[ Setup Help ]	
System Time 20:07:40		Month: Jan - Dec	
▶ Floppy Drives		Day: 01 - 31	
▶ IDE Devices		Year: 1980 - 2099	
BIOS Version GE Pro-HT BIOS P1.00			
Processor Type Pentium (R) 4 Family CPU			
Processor Speed 2100 MHz			
Cache Size 512 KB			
Microcode Update F23 / 08			
Total Memory 224 MB + 32 MB Share Memory			
DDR1 256 MB / 333 MHz			
DDR2 None			
SDR1 None			
SDR2 None			
F1:Help	↑↓:Select Item	+/-:Change Values	F9:Setup Defaults
Esc:Exit	←→:Select Menu	Enter:Select	F10:Save & Exit
		▶Sub-Menu	

### System Date [Month/Day/Year]

Set the system date that you specify. Valid values for month, day, and year are Month: (Jan to Dec), Day: (1 to 31), Year: (up to 2099). Use ↑ ↓ keys to move between the Month, Day and Year fields.

### System Time [Hour:Minute:Second]

Set the system to the time that you specify. Use ↑ ↓ keys to move between the Hour, Minute and Second fields.

### Floppy Drives

Use this to set the type of floppy drives installed.

### IDE Devices

Use this to configure IDE devices.



AMIBIOS SETUP UTILITY - VERSION 3.31a	
Main	
<b>Primary IDE Master:</b>  Type <span style="float: right;">Auto</span> Cylinders Heads Write Precompensation Sectors Maximum Capacity <span style="float: right;">0 Mb</span> LBA Mode <span style="float: right;">Off</span> Block Mode <span style="float: right;">Off</span> Fast Programmed I/O Modes <span style="float: right;">Auto</span> 32 Bit Transfer Mode <span style="float: right;">Off</span> Ultra DMA Mode <span style="float: right;">Auto</span>	[ Setup Help ]  Select how to set the parameters of drive,  Or Select [AUTO] to set all HDD parameters automatically.
F1:Help Esc:Previous Menu	↑↓:Select Item +/-:Change Values Enter:Select   ▶Sub-Menu
F9:Setup Defaults F10:Save & Exit	

## TYPE

It allows user to select the type of the IDE Drive. Below are the configuration options. After making your selections on this sub-menu, press <ESC> key to return to the upper menu, in which the hard disk drive field will display the size for the hard disk drive that you configured.

**[USER]:** It allows user to manually enter the number of cylinders, heads, and sectors per track for the drive.



Before attempting to configure a hard disk drive, make sure you have the correct configuration information supplied by the drive manufacturer. Incorrect settings may cause the system to fail to recognize the installed hard disk.

**[Auto]:** Select [Auto] to automatically detect hard disk drive. If auto-detection is successful, the BIOS Setup automatically fills in the correct values for the remaining fields on this sub-menu. If the auto-detection fails, it may be due to that the hard disk is too old or too new. If the hard disk was already formatted on an older system, the BIOS Setup may detect incorrect parameters. In these cases, select [User] to manually enter the IDE hard disk drive parameters.



After entering the hard disk information into BIOS, use a disk utility, such as FDISK, to partition and format new IDE hard disk drives. This is necessary so that you can write or read data from the hard disk. Make sure to set the partition of the Primary IDE hard disk drives to active.

---

**[CD/DVD]:** This is used for IDE CD/DVD drives.

**[ARMD]:** This is used for IDE ARMD (Accelerated Removable Media Device), such as MO.

**Cylinders**

This is used to configure the number of cylinders. Refer to the drive documentation to determine the correct value.

**Heads**

This is used to configure the number of read/write heads. Refer to the drive documentation to determine the correct values.

**Write Pre-compensation**

Enter Write Pre-compensation sector. Refer to the drive documentation to determine the correct value.

**Sectors**

This is used to configure the number of sectors per track. Refer to the drive documentation to determine the correct value.

**Maximum Capacity**

This field shows the drive's maximum capacity as calculated by the BIOS based on the drive information you entered.

**LBA Mode**

This allows user to select the LBA mode for a hard disk > 512 MB under DOS and Windows; for Netware and UNIX user, select [Off] to disable the LBA mode.

**Block Mode**

Set the block mode to [On] will enhance hard disk performance by reading or writing more data during each transfer.

**Fast Programmed I/O Modes**

This allows user to set the PIO mode to enhance hard disk performance by optimizing the hard disk timing.

**32 Bit Transfer Mode**

It allows user to enable 32-bit access to maximize the IDE hard disk data transfer rate.

**Ultra DMA Mode**

Ultra DMA capability allows improved transfer speeds and data integrity for compatible IDE devices. Set to [Disabled] to suppress Ultra DMA capability.

### 3.3 Advanced, Security, Power, Boot, and Exit Menus

Detailed descriptions of these menus are listed in the Appendix. See page 20.

---

# Chapter 4 Software Support

## 4.1 Install Operating System

This motherboard supports various Microsoft® Windows® operating systems: 98 SE/ ME/ 2000/ XP. Because motherboard settings and hardware options vary, use the setup procedures in this chapter for general reference only. Refer to your OS documentation for more information.

## 4.2 Support CD Information

The Support CD that came with the motherboard contains necessary drivers and useful utilities that enhance the motherboard features.

### 4.2.1 Running The Support CD

To begin using the support CD, insert the CD into your CD-ROM drive. The CD automatically displays the Main Menu if "AUTORUN" is enabled in your computer. If the Main Menu did not appear automatically, locate and double click on the file ASSETUP.EXE from the BIN folder in the Support CD to display the menus.

### 4.2.2 Drivers Menu

The Drivers Menu shows the available devices drivers if the system detects installed devices. Install the necessary drivers to activate the devices.

### 4.2.3 Utilities Menu

The Utilities Menu shows the applications software that the motherboard supports. Click on a specific item then follow the installation wizard to install it.

### 4.2.4 ASRock PC-DIY Live Demo Program

ASRock presents you a multimedia PC-DIY live demo, which shows you how to install your own PC system step by step. You can find the file through the following path:

..\MPEGAV\AVSEQ01.DAT

To see this demo program, you can run Microsoft Media Player to play the file.

### 4.2.5 Contact Information

If you need to contact ASRock or want to know more about ASRock, welcome to visit ASRock's website at <http://www.asrock.com>; or you may contact your dealer for further information.

---

# Appendix: Advanced BIOS Setup

This section will introduce you the following BIOS Setup menus: "Advanced," "Security," "Power," "Boot," and "Exit."

## 1. Advanced BIOS Setup Menu

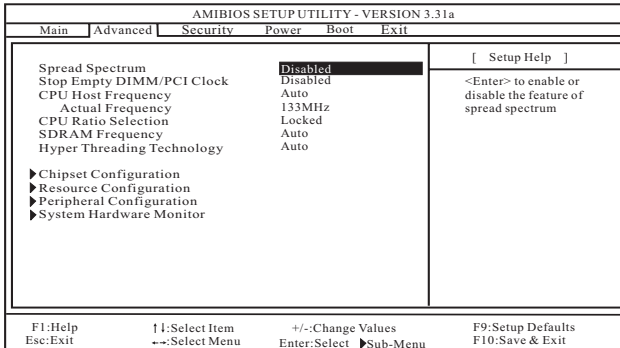

### Spread Spectrum:

This field should always be [Disabled] for better system stability.

### Stop Empty DIMM/PCI Clock:

When this option is set to [Enabled], it will function to stop the clock of any empty DIMM or PCI slot.

### CPU Host Frequency:

This shows current CPU host frequency of the installed motherboard.

### CPU Ratio Selection:

CPU Ratio is the multiple that times the frontside bus frequency will equal the core speed of the installed processor. Whether the option is open or locked is determined by the installed processor.

### SDRAM Frequency:

If [Auto] is selected, the motherboard detects the memory module(s) inserted and automatically assigns appropriate frequency. You can also select other value as operating frequency: [200MHz], [266MHz], [333MHz].

### Hyper-Threading Technology (for GE Pro-HT only):

To enable this feature, it requires a computer system with an Intel Pentium®4 processor at 3.06 GHz or higher and an operating system that includes optimization for this technology, such as Microsoft® Windows® XP. Set to [Auto] if using Microsoft® Windows® XP, or Linux kernel version 2.4.18 or higher. This option will be hidden if the current CPU does not support Hyper-Threading Technology.

## Chipset Configuration:

AMIBIOS SETUP UTILITY - VERSION 3.31a		
Advanced		[ Setup Help ]
Chipset Configuration		[ Setup Help ]
AGP Aperture Size	32MB	<Enter> to select the size of mapped memory for graphics data.
Onboard VGA Share Memory	4MB	
USB Controller	Disabled	
USB Device Legacy Support	Disabled	
F1:Help      ↑:Select Item      +/-:Change Values      F9:Setup Defaults Esc:Previous Menu      Enter:Select      ▶Sub-Menu      F10:Save & Exit		

**AGP Aperture Size:** It refers to a section of the PCI memory address range used for graphics memory. We recommend that you leave this field at the default value unless your AGP card requires other sizes.

**Onboard VGA Share Memory:** This allows you to select the size of share memory for onboard VGA. Onboard VGA will get better resolution if larger size of share memory is selected. Please do not select [None] if AGP or PCI graphics card is not inserted.

**USB Controller:** Use this to enable or disable the use of USB controller.

**USB Device Legacy Support:** Use this to enable or disable support to emulate legacy I/O devices such as mouse, keyboard,... etc.

## Resource Configuration:

AMIBIOS SETUP UTILITY - VERSION 3.31a		
Advanced		[ Setup Help ]
Resource Configuration		[ Setup Help ]
PCI Latency Timer (PCI Clocks)	32	
Primary Graphics Adapter	AGP	
F1:Help      ↑:Select Item      +/-:Change Values      F9:Setup Defaults Esc:Previous Menu      Enter:Select      ▶Sub-Menu      F10:Save & Exit		

**PCI Latency Timer (PCI Clocks):** The default is 32. We recommend you to keep the default value unless your PCI expansion cards' specifications require other settings.

**Primary Graphics Adapter:** Select PCI, OnBoard VGA, or Add-on AGP as the primary graphics adapter.

## Peripheral Configuration:

AMIBIOS SETUP UTILITY - VERSION 3.31a		
Advanced		
Peripheral Configuration		[ Setup Help ]
OnBoard FDC	Auto	<Enter> to enable or disable the floppy drive controller.
OnBoard Serial Port	Auto	
OnBoard Infrared Port	Auto	
OnBoard Parallel Port	Auto	
Parallel Port Mode	Normal	
EPP Version	N/A	
Parallel Port IRQ	Auto	
Parallel Port DMA Channel	N/A	
OnBoard Midi Port	Disabled	
Midi IRQ Select	5	
OnBoard Game Port	Disabled	
OnBoard IDE	Disabled	
OnBoard LAN	Disabled	
OnBoard AC'97 Audio	Auto	
OnBoard MC'97 Modem	Disabled	
F1:Help Esc:Previous Menu	↑:Select Item Enter:Select	+/-:Change Values ▶:Sub-Menu
		F9:Setup Defaults F10:Save & Exit

**OnBoard FDC:** Use this to enable or disable floppy drive controller.

**OnBoard Serial Port:** Use this to set addresses for the onboard serial ports or disable serial ports. Configuration options: [Auto], [Disabled], [3F8 / IRQ4 / COM1], [2F8 / IRQ3 / COM2], [3E8 / IRQ4 / COM3], [2E8 / IRQ3 / COM4].

**OnBoard Infrared Port:** This allows you to enable or disable the onboard infrared port feature. Select [Auto] will enable this feature if the infrared module is installed.

**OnBoard Parallel Port:** Select Parallel Port address or disable Parallel Port. Configuration options: [Auto], [Disabled], [378], [278].

**Parallel Port Mode:** Set the operation mode of the parallel port.

**OnBoard Midi Port:** Select address for Midi Port or disable Midi Port. Configuration options: [Disabled], [330], [300], [290], [292].

**Midi IRQ Select:** Use this to select Midi IRQ. Configuration options: [5], [10], [11]. The default is 5.

**OnBoard Game Port:** Select address for Game Port or disable Game Port. Configuration options: [200h], [208h], [Disabled].

**OnBoard IDE:** To enable either the primary IDE channel or the secondary IDE channel, set to [Disabled] will disable the both.

Configuration options: [Disabled], [Primary], [Secondary], [Both].

**OnBoard LAN:** Enable or Disable onboard LAN.

**OnBoard AC'97 Audio:** Enable or disable onboard AC'97 audio feature.

**OnBoard MC'97 Modem:** Enable or disable onboard MC'97 modem feature.

**System Hardware Monitor:** You can check the status of the hardware on your system. It allows you to monitor the parameters for CPU temperature, Motherboard temperature, CPU fan speed, and critical voltage.

AMIBIOS SETUP UTILITY - VERSION 3.31a			
Advanced			
System Hardware Monitor		[ Setup Help ]	
CPU Temperature	35°C / 95°F		
M/B Temperature	27°C / 82°F		
CPU Fan Speed	3110 RPM		
Chassis Fan Speed	0 RPM		
Vcore	1.728 V		
+ 3.30V	3.312 V		
+ 5.00V	4.975 V		
+12.00V	12.167 V		
F1:Help Esc:Previous Menu	F11:Select Item	+/-:Change Values Enter:Select	F9:Setup Defaults F10:Save & Exit
			Sub-Menu

## 2. Security Setup Menu

AMIBIOS SETUP UTILITY - VERSION 3.31a			
Main	Advanced	Security	Power Boot Exit
Supervisor Password		Clear	[ Setup Help ]
User Password		Clear	<Enter> to enable or disable the quick boot mode.
Set Supervisor Password		[ Enter ]	
Set User Password		[ Enter ]	
Password Check		Setup	
F1:Help Esc:Exit	F11:Select Item --:Select Menu	+/-:Change Values Enter:Select	F9:Setup Defaults F10:Save & Exit
			Sub-Menu

**Supervisor Password:** This field shows the status of the Supervisor Password.

**[Clear]:** No password has been set.

**[Set]:** Supervisor password has been set.

**User Password:** This field shows the status of the User Password.

**[Clear]:** No password has been set.

**[Set]:** User password has been set.

**Set Supervisor Password:** Press <Enter> to set Supervisor Password. Valid password can be a 1 to 6 alphanumeric characters combination. If you already have a password, you must enter your current password first in order to create a new password.

**Set User Password:** Press <Enter> to set User Password. Valid password can be a 1 to 6 alphanumeric characters combination. If you already have a password, you must enter your current password first in order to create a new password.

**Password Check:** Select the check point for “Password Check”. Configuration options: [Setup], [Always]. If [Setup] option is selected, the “Password Check” is performed before BIOS setup. If [Always] option is selected, the “Password Check” is performed before both boot-up and BIOS setup.

### 3. Power Setup Menu

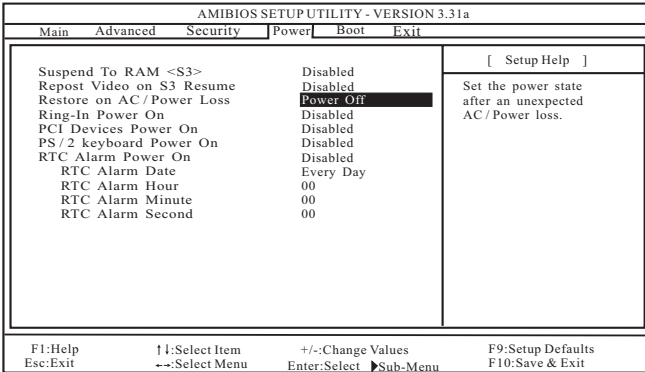

**Suspend to RAM (S3):** This field allows you to select whether to auto-detect or disable the ACPI Suspend-to-RAM feature. Select [Auto] will enable this feature if the system supports it.

**Repost Video on S3 Resume:** This feature allows you to repost video on S3 resume. It is recommended to enable this feature under Microsoft® Windows® 98 / ME.

**Restore on AC/Power Loss:** This allows you to set the power state after an unexpected AC power loss. If [Power Off] is selected, the AC power remains off when the power recovers. If [Power On] is selected, the AC power resumes and the system starts to boot up when the power recovers.

**Ring-In Power On:** Use this to enable or disable Ring-in signals to turn on the system from the power-soft-off mode.

**PCI Devices Power On:** Use this to enable or disable PCI devices to turn on the system from the power-soft-off mode.

**PS/2 Keyboard Power On:** Use this to enable or disable PS/2 keyboard to turn on the system from the power-soft-off mode.

**RTC Alarm Power On:** Use this to enable or disable RTC(Real Time Clock) to power on the system. If [Enable] is selected, you must fill the RTC Alarm Date / Hour / Minute / Second sub-fields with the actual wake up time you desire.



---

## 4. Boot Setup Menu

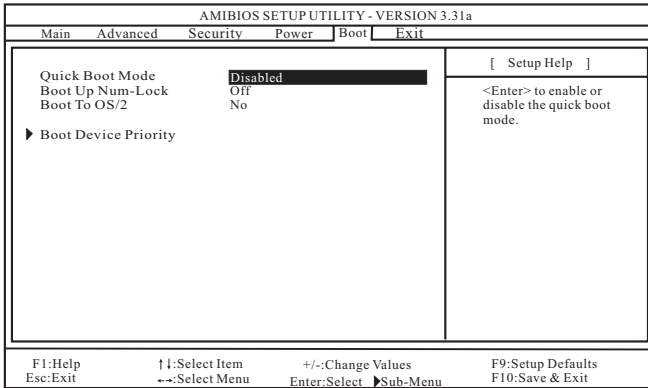

**Quick Boot Mode:** This mode speeds up the boot-up routine by skipping memory retestings.

**Boot Up Num-Lock:** This automatically activates the Numeric Lock function after boot up.

**Boot to OS/2:** This enables boot up to OS/2 operating system.

**Boot Device Priority:** This allows you to set the boot device priority.

## 5. Exit Menu

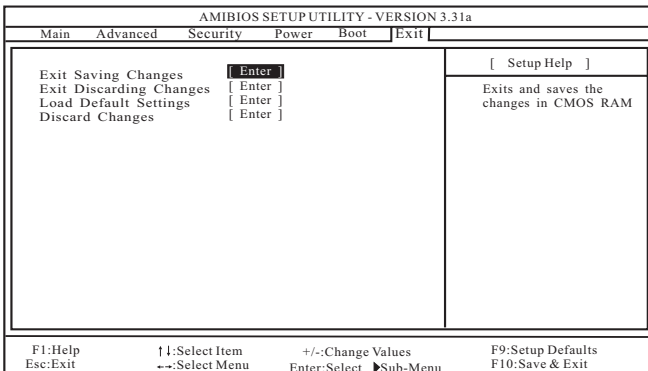

**Exit Saving Changes:** After you enter the sub-menu, the message "Save current settings and exit" will appear. If you press <ENTER>, it will save the current settings and exit the BIOS SETUP Utility.

---

**Exit Discarding Changes:** After you enter the submenu, the message “Quit without saving changes” will appear. If you press <ENTER>, you will exit the BIOS Setup Utility without making any changes to the settings.

**Load Default Settings:** After you enter the submenu, the message “Load Default Settings” will appear. If you press <Enter>, it will load the default values for all the setup configuration.

**Discard Changes:** After you enter the sub-menu, the message “Load setup original values” will appear. If you press <ENTER>, original values will be restored. All changes are discarded.