

# DIGITAL PC 3010

---

## System Maintenance Manual

Part Number: ER-F3GWW-SM. A01

**Digital Equipment Corporation**

**October 1997**

---

The information in this document is subject to change without notice and should not be construed as a commitment by Digital Equipment Corporation.

Digital Equipment Corporation assumes no responsibility for any errors that might appear in this document.

The software described in this document is furnished under a license and may be used or copied only in accordance with the terms of such license. No responsibility is assumed for the use or reliability of software or equipment that is not supplied by Digital Equipment Corporation or its affiliated companies.

Restricted Rights: Use, duplication, or disclosure by the U.S. Government is subject to restrictions as set forth in subparagraph (c) (1) (ii) of the Rights in Technical Data and Computer Software clause at DFARS 252.227-7013.

*DIGITAL PC 3010 System Maintenance Manual*

Copyright © Digital Equipment Corporation.

All Rights Reserved.

AMD is a trademark of Advanced Micro Devices, Inc.

DEC and the DIGITAL logo are registered trademarks of Digital Equipment Corporation.

Intel and Pentium are registered trademarks of Intel Corporation.

Microsoft and Windows 95 are registered trademarks of Microsoft Corporation.

All other trademarks and registered trademarks are the property of their respective holders.

## FCC Notice

This equipment has been tested and found to comply with the limits for a Class B digital device, pursuant to Part 15 of the FCC rules. These limits are designed to provide reasonable protection against harmful interference in a residential installation.

Any changes or modifications made to this equipment may void the user's authority to operate this equipment.

This equipment generates, uses, and can radiate radio frequency energy and, if not installed and used in accordance with the instructions, may cause harmful interference to radio communications. However, there is no guarantee that interference will not occur in a particular installation. If this equipment does cause harmful interference to radio or television reception, which can be determined by turning the equipment off and on, the user is encouraged to try to correct the interference by one or more of the following measures:

- Reorient or relocate the receiving antenna
- Increase the separation between the equipment and receiver
- Connect the equipment into an outlet on a circuit different from that to which the receiver is connected
- Consult the dealer or an experienced radio/TV technician for help

The user may find the following booklet prepared by the Federal Communications Commission helpful: How to Identify and Resolve Radio-TV Interference Problems. This booklet is available from the U.S. Government Printing Office, Washington, D.C., 20402. Stock No. 004-00398-5.

All external cables connecting to this basic unit need to be shielded. For cables connecting to option boards, see the option manual or installation instructions.

## Canadian DOC Notice

This digital apparatus does not exceed the Class B limits for radio noise emissions set out in the radio interference regulations of the Canadian Department of Communications.

## VCCI Notice

This equipment is in the 2nd Class category (information equipment to be used in a residential area or an adjacent area thereto) and conforms to the standards set by the Voluntary Control Council For Interference by Data Processing Equipment and Electronic Office Machines aimed at preventing radio interference in such residential area.

When used near a radio or TV receiver, it may become the cause of radio interference.

Read the instructions for correct handling.

## German Ergonomic Notice

This equipment meets or exceeds the ergonomic requirements of ZH1/618 and is certified to bear the GS mark by TUV Rheinland of Germany.

## Safety Requirements

This equipment meets or exceeds requirements for safety in the U.S. (UL 1950), Canada (CSA C22.2 No. 950), and Europe (EN 60950/IEC 950) with Nordic requirements.



**WARNING:** There is a danger of battery explosion if a lithium battery is incorrectly replaced. To prevent damage to your computer, be sure the + side faces up when installing a new battery. Also, be sure you replace the battery with either a DIGITAL (P/N 12-41474-05), Toshiba (P/N CR2032), or equivalent 3 V dc lithium battery.

Depending on your locality, your computer's battery might be considered hazardous waste. Make sure you follow any state or local statute to properly dispose of the old battery.



**ADVARSEL:** Der er fare for, at et lithiumbatteri eksploderer, hvis det udskiftes ukorrekt. Undgå, at beskadige din computer - HUSK, at + siden skal vende opad, når du installerer et nyt batteri. Du skal udskifte batteriet med enten et DIGITAL (delnummer 12-41474-05), Toshiba (delnummer CR2032), eller tilsvarende 3 V jævnstrøms lithiumbatteri.

Afhængig af dit lokalområde, er det muligt, at din computers batteri betragtes som farligt affald. Husk, at følge evt. miljølove og lokale bestemmelser, når du kasserer det gamle batteri.



**VAROITUS:** Litiumpatterit voivat räjähtää, jos ne asennetaan väärin. Estääksesi tietokoneesi vaurioitumisen varmista, että patteria asentaessasi sen positiivinen (+) puoli on ylöspäin. Tarkista myös, että käyttämäsi uusi patteri on joko DIGITAL (osa no. 12-41474-05), Toshiba (osa no. CR2032) tai vastaavanlainen 3 voltin tasavirtalitiumpatterii.

Asuinpaikastasi riippuen tietokoneesi patteria voidaan pitää ongelmajätteenä. Pidä huoli, että hävität vanhan patterin voimassa olevien lakien ja asetusten mukaisesti.



**WARNING!** Det kan förekomma en batteriexplosion om ett litium-jonbatteri byts ut på felaktigt sätt. Förhindra att datorn skadas genom att se till att plussidan (+) är uppåtvänd när du sätter i ett nytt batteri. Det gamla batteriet får endast bytas ut mot ett DIGITAL-batteri (artikelnummer 12-41454-05), ett Toshiba-batteri (artikelnummer CR2032) eller ett motsvarande litiumbatteri på 3 volt likström.

Datorbatterier anses vara miljöfarligt avfall i många länder. Du måste följa alla lokala bestämmelser när du avyttrar ett gammalt batteri.

## **Laser Safety Notices**

All CD-ROM drives included in DIGITAL computers are classified as Class 1 laser products and comply with safety standards as set by U.S. government and applicable European agencies.

No hazardous radiation is emitted from this CD-ROM drive; the laser beam is completely enclosed in the CD-ROM subassembly during all customer operation and maintenance. In the event that repair or service of the CD-ROM subassembly is required, only authorized DIGITAL service personnel should perform such repairs.

## **Energy Star Compliant**

The DIGITAL PC 3010 series of computers are ENERGY STAR compliant when used with Windows 95. DIGITAL advises that you do not use the enable Power Management features with operating systems that do not allow for power management, such as SCO UNIX, Windows NT, or OS/2.

To ensure that your entire computer system remains ENERGY STAR compliant, you must use an ENERGY STAR compliant monitor, that is, a monitor that supports the DPMS protocol.

# Contents

<b>Preface</b> .....	iv
<b>1</b>	
<b>Product Description</b>	
Introduction .....	1-1
DIGITAL PC 3010 Models with AMD Processors.....	1-2
DIGITAL PC 3010 Models with Intel Processors .....	1-3
Related Material.....	1-4
Latest Product Information and Updates .....	1-6
<b>2</b>	
<b>BIOS Setup Utility</b>	
Running the BIOS Setup Utility.....	2-1
Helpful Hints.....	2-2
BIOS Setup Utility Options.....	2-3
Main .....	2-4
Advanced .....	2-8
Security Options.....	2-11
Power .....	2-12
Boot.....	2-14
Flash Utility .....	2-15

DIGITAL PC 3010

## Contents

### 3

#### System Software

Introduction .....	3-1
Factory Installed Software .....	3-2
DIGITAL System Software CD .....	3-2
DIGITAL System Software CD Installation Program .....	3-3
On-Line Documentation .....	3-4
Applications .....	3-5
DIGITAL Startup Diskette .....	3-6
Operating System Kit.....	3-6
Integrated Desktop Manageability .....	3-7
ClientWORKS .....	3-7
Self Monitoring Analysis Technology (S.M.A.R.T.) .....	3-8
Configuring System Parameters.....	3-9
Configuring Video.....	3-9
Configuring Additional Hardware.....	3-10
Using Diagnostics .....	3-10
Restoring Your Software.....	3-11
Additional Device Drivers .....	3-13

### 4

#### Troubleshooting

Initial Troubleshooting.....	4-1
Pass/Fail Criteria.....	4-3
Diagnostics .....	4-4
DIGITAL ClientWORKS and DMI .....	4-5
Self Monitoring Analysis Technology (S.M.A.R.T.) .....	4-6
Advanced Troubleshooting .....	4-7
Computer Troubleshooting .....	4-8
Disk Drive Troubleshooting.....	4-19
Monitor Troubleshooting.....	4-21
Error Messages .....	4-23
POST Messages .....	4-23
POST and Boot Messages .....	4-24
POST Execution Messages.....	4-27
Beep Codes.....	4-33



**5****Parts Replacement**

Introduction .....	5-1
DIGITAL PC 3010 IPB List .....	5-2
Enclosure .....	5-4
Cables .....	5-5
Nameplates .....	5-5
Options .....	5-6
Service Procedures .....	5-7
Recommended Tools .....	5-7
Other Materials Needed .....	5-7
Special Tools Required .....	5-7
Remedial Diagnostic Test Software .....	5-8
Virus Software Information .....	5-8
BIOS Version Information .....	5-8
Disconnecting External Devices and Power .....	5-9
Removing the Outside Cover .....	5-10
Computer Components .....	5-12
Main Logic Board Components and Connectors .....	5-12
Main Logic Board Connectors (Rear Panel) .....	5-14
Backplane Components and Connectors .....	5-15
Expansion Slot Locations .....	5-17
Main Logic Board Jumper Settings .....	5-18
Installing Additional Computer Memory .....	5-21
Memory Configurations .....	5-23
Removing and Replacing Components .....	5-24
Removing the Main Logic Board .....	5-25
Removing the DIMMs .....	5-27
Removing the Lithium Battery .....	5-29
Removing the Processor Heat Sink .....	5-31
Removing the Processor .....	5-33
Removing the Backplane .....	5-34
Removing Expansion Boards .....	5-36
Removing the Power Supply .....	5-38
Removing the Control Panel Assembly .....	5-40
Removing a 3½-Inch Device from the Front Bay .....	5-41
Removing a 5¼-Inch Device from the Front Bay .....	5-43
Removing the Internal 3½-Inch Device .....	5-45
Removing the Diskette Drive .....	5-47
Diskette and IDE Drive Data Cable Connectors .....	5-49

## Contents

### 6

## Device Mapping

Introduction .....	6-1
Full Range Processor Memory Address Map .....	6-2
I/O Address Map .....	6-3
Computer Interrupt Levels .....	6-5
DMA Channel Assignment .....	6-6

### A

<b>Service Notes</b> .....	A-1
----------------------------	-----

## Figures

5-1. Digital PC 3010 .....	5-3
5-3. Removing The Outside Cover .....	5-11
5-4. Main Logic Board Components .....	5-13
5-5. Main Logic Board Components (Rear Panel) .....	5-14
5-7. Backplane Components And Connectors .....	5-16
5-10. Expansion Board Slots .....	5-17
5-12. Main Logic Board Switch Settings .....	5-20
5-13. DIMM Socket Locations .....	5-22
5-14. Removing The Main Logic Board .....	5-26
5-16. Removing DIMMs .....	5-28
5-18. Removing The Lithium Battery .....	5-30
5-19. Removing The Processor Heat Sink .....	5-32
5-21. Removing The Backplane .....	5-35
5-23. Removing Expansion Boards .....	5-37
5-24. Removing The Power Supply .....	5-39
5-26. Removing The Control Panel Assembly .....	5-40
5-32. Removing A 3½-Inch Device From The Front Bay .....	5-42
5-33. Removing A 5¼-Inch Device From The Front Bay .....	5-44
5-38. Removing The Internal 3½-Inch Device .....	5-46
5-39. Removing The Diskette Drive .....	5-48
5-40. Diskette Drive Data Cable Connections .....	5-49
5-41. IDE Drive Data Cable Connections .....	5-51

# Preface *P*

---

This *Service Maintenance Manual* is a troubleshooting guide that can be used for reference when servicing DIGITAL PC 3010 computers.

DIGITAL reserves the right to make changes to this *Service Maintenance Manual* without notice. Accordingly, the illustrations and procedures in this document might not apply to all DIGITAL PC 3010 computers to be serviced since many of the diagnostic tests are designed to test more than one product.



**CAUTION:** DIGITAL recommends that only A+ certified engineers attempt to repair this equipment. All troubleshooting and repair procedures are detailed to support subassembly/module level exchange. Because of the complexity of the individual boards and subassemblies, no one should attempt to make repairs at the component level or make modifications to any printed circuit board. Improper repairs can create a safety hazard. Any indications of component replacement or circuit board modifications might void any warranty or exchange allowances.

# Product Description

# 1

## Introduction

DIGITAL PC 3010 computers are high-performance personal computers featuring the latest in computing technology. They can be used as stand-alone computers or as clients in a network environment. Developed using the following state-of-the-art technology, these computers are the most value packed computers in their class.

- *Microprocessor* — ZIF Socket 7-compatible processor with 256 KB level 2 cache
- *Memory* — Up to 256 MB of SDRAM via two-unbuffered DIMM sockets
- *Plug and Play* — Optional Plug and Play compatible expansion boards are automatically configured for easy installation
- *PCI local bus* — The computer's PCI architecture represents the latest in local bus technology
- *Onboard video* — Unified Memory Architecture (UMA) for video buffering enables the video frame buffer to be mapped into computer memory. No additional video memory is required.

Product Description

## DIGITAL PC 3010 Models with AMD Processors

Part Number	Description	Video	HDD (IDE)	RAM	Additional Features
FR-F3G2W-WB	5166 LP	SiS 5597 2D	1.2 GB	16 MB	AMD-K5, 1.44 Diskette drive, 256 KB external cache, Country Kit required
FR-F3G3W-WB	5200 LP	SiS 5597 2D	1.2 GB	16 MB	AMD-K5, 1.44 Diskette drive, 256 KB external cache, Country Kit required
FR-F3H2W-WB	6166 LP	SiS 5597 2D	1.2 GB	16 MB	AMD-K6, 1.44 Diskette drive, 256 KB external cache, Country Kit required
FR-F3G2A-EB	5166 LP	SiS 5597 2D	1.2 GB	16 MB	AMD-K5, 1.44 Diskette drive, 256 KB external cache, U.S. Country Kit, Windows 95
FR-F3G3A-EB	5200 LP	SiS 5597 2D	1.2 GB	16 MB	AMD-K5, 1.44 Diskette drive, 256 KB external cache, U.S. Country Kit, Windows 95
FR-F3H2A-EB	6166 LP	SiS 5597 2D	1.2 GB	16 MB	AMD-K6, 1.44 Diskette drive, 256 KB external cache, U.S. Country Kit, Windows 95

## DIGITAL PC 3010 Models with Intel Processors

Part Number	Description	Video	HDD (IDE)	RAM	Additional Features
FR-F3E5W-WB	5166 LP	S3 Trio64 V2/GX 2D	1.2 GB	16 MB	Intel Pentium, 1.44 Diskette drive, 256 KB external cache, Country Kit required
FR-F3E6W-WB	5200 LP	S3 Trio64 V2/GX 2D	1.2 GB	16 MB	Intel Pentium, 1.44 Diskette drive, 256 KB external cache, Country Kit required
FR-F3D4W-WB	5166 LP	S3 Trio64 V2/GX 2D	1.2 GB	16 MB	Intel Pentium with MMX, 1.44 Diskette drive, 256 KB external cache, Country Kit required
FR-F3D5W-WB	5200 MMX LP	S3 Trio64 V2/GX 2D	1.2 GB	16 MB	Intel Pentium with MMX, 1.44 Diskette drive, 256 KB external cache, Country Kit required
FR-F3E5A-EB	5166 LP	S3 Trio64 V2/GX 2D	1.2 GB	16 MB	Intel Pentium, 1.44 Diskette drive, 256 KB external cache, U.S. Country Kit, Windows 95
FR-F3E6A-EB	5200 LP	S3 Trio64 V2/GX 2D	1.2 GB	16 MB	Intel Pentium, 1.44 Diskette drive, 256 KB external cache, U.S. Country Kit, Windows 95
FR-F3D4A-EB	5166 MMX LP	S3 Trio64 V2/GX 2D	1.2 GB	16 MB	Intel Pentium with MMX, 1.44 Diskette drive, 256 KB external cache, U.S. Country Kit, Windows 95
FR-F3D5A-EB	5200 MMX LP	S3 Trio64 V2/GX 2D	1.6 GB	16 MB	Intel Pentium with MMX, 1.44 Diskette drive, 256 KB external cache, U.S. Country Kit, Windows 95

## Related Material

The following related material is available:

Document Title	Order Number	Description
Service Quick Reference	ER-F3GWW-SR	Provides troubleshooting information that can be used when servicing DIGITAL PC 3010 computers.
Quick Setup Guide	ER-F3GWW-IM (Multilanguage)* ER-F3GWW-I8 (Multilanguage)†	Describes how to initially setup DIGITAL PC 3010 computers.
System Reference	ER-F3GWW-UA (English) ER-F3GWW-UJ (Japanese) ER-F3GWW-U2 (simple Chinese) ER-F3GWW-U3 (traditional Chinese)	Describes how to operate, configure, and upgrade DIGITAL PC 3010 computers.
System Solutions	ER-PCDSS-UA (English) ER-PCDSS-UM (Multilanguage)* ER-PCDSS-U8 (Multilanguage)††	Provides end-user troubleshooting information should a DIGITAL PC 3010 computer fail to operate after initial setup or after installing optional devices.
System Software	ER-F3GWW-GA (English) ER-F3GWW-GM (Multilanguage)** ER-F3GWW-G8 (Multilanguage)††	Provides information on the operating system, utilities, and device drivers that came with the DIGITAL PC 3010 computer.
Warranty and Service	ER-PCWAR-CM (Multilanguage)** EK-PCJHW-RI (Japanese) EK-DCPCS-RC (simple Chinese)	Provides warranty information and a listing of phone numbers for technical support.
Backup Media	QC-04VAB-HW QC-05JAA-HC1.0 QC-05JJA-HC1.0	DIGITAL PC 3010 System Software CD Digital Startup Diskette (English) Digital Startup Diskette (Japanese)
Service Media	QA-5RJAA-G8	DIGITAL PC Product Support CD Kit

\* Multilanguage includes: English, French, Italian, German, Spanish, and Brazilian Portuguese

\*\* Multilanguage includes: English, French, Italian, German, and Spanish

† Multilanguage includes: English, Japanese, Simple Chinese, Traditional Chinese, Thai

†† Multilanguage includes: English, Japanese, Simple Chinese, and Traditional Chinese

README files come with the factory installed software and on the supplied DIGITAL System Software CD. These files contain useful setup, configuration, and operation information. Read this information first.

## **Latest Product Information and Updates**

You can access product information and download the latest BIOS, device drivers, and software updates using the Internet at:

**<http://www.windows.digital.com>**



# BIOS Setup Utility **2**

---

## Running the BIOS Setup Utility

The BIOS Setup utility enables you to select and store permanently information about the computer's hardware and software in the battery-backed memory of the CMOS RAM. This information takes effect each time the computer boots and can be changed any time you run setup.

You should use the BIOS Setup utility if you experience problems with the hard disk or if you need to reconfigure or expand the computer. In addition, the BIOS Setup utility might need to be used to modify the configuration after adding or removing hardware, or changing computer settings.



**CAUTION:** The computer was setup for normal operation at the factory and will operate properly without additional configuring.

It is important for you to read carefully and understand this chapter before attempting to modify the computer's factory settings. Changing some settings might cause the computer to operate improperly.

To access the BIOS Setup utility, perform the following steps:

1. Turn on the computer and allow the Power-On Self Test (POST) to complete.
2. Make a note of any configuration errors listed, and then press [F2] to display the Main menu.
3. Follow the instructions on the monitor screen and any on-line help pop-up screens to configure you computer.

## Helpful Hints

- Several keyboard keys are assigned to help you select menus and sub-menus, options, change option values, and display help information. These keys are displayed at the bottom of the main menu and from the General Help pop-up screen.
- Item-specific help is available anytime during the setup process and appears at the right of the setup screen when an option is highlighted. This on-line help provides information about a highlighted option.
- Select *Exit Saving Changes* to save all Setup values and exit Setup.
- Select *Exit Discarding Changes* to exit Setup without recording any changes.
- Select *Load Setup Defaults* to set all Setup options to their default values.
- Select *Discard Changes* to restore all CMOS values from the last session.
- Select *Save Changes* to save all selections without exiting Setup.
- Press [Esc] to exit the BIOS Setup utility.

## BIOS Setup Utility Options

The following Help topics list the BIOS options that can be updated or modified by using the BIOS Setup utility, according to the various sub-menus under which they appear.

- Main Menu Options — Sets basic computer configuration options (time, date, video, memory & cache, etc.).
- Advanced Options — Sets advanced features to increase computer performance (COM ports, LPT ports, etc.).
- Security Options — Sets passwords and user privileges.
- Power Options — Sets power saving options to increase the life of the computer.
- Boot Options — Sets the boot sequence of the computer.
- Exit — Provides options for saving changes and leaving the BIOS Setup utility. Refer to “Navigating,” in the BIOS Setup utility, for additional information.



**NOTE:** The following tables list the BIOS Setup Menu options available for DIGITAL PC 3010 computers. Note that an “ \* ” that follows an option in the Settings column indicates the factory default setting.

## Main

Menu Fields	Settings	Comments
System time	Current time	Displays the current time.
System date	Current date	Displays the current date.
Diskette drive A/ Diskette drive B	360 KB, 5¼ 1.2 MB, 5¼ 720 KB, 3½ 1.44/1.25 MB, 3½ 2.88 MB Disabled	Sets the size and density of diskette drives.
<b>Primary/Secondary Master/Slave</b>		
Autotype fixed disk	[Press Enter]	Press [Enter] to detect and fill in the installed hard disk drive parameters in the remaining fields.
Type <sup>(1)</sup>	None User Auto* CD-ROM	Selecting <code>User</code> enables the remaining fields to be filled in manually, using the installed hard disk drive's parameters. <sup>(2)</sup>  If a CD-ROM drive is used for the IDE drive, you must select <code>CD-ROM</code> . You can select <code>Auto</code> for a hard disk drive.
Cylinders <sup>(1)</sup>	0 to 65535	Displays the number of cylinders.
Heads <sup>(1)</sup>	1 to 16	Displays the number of heads.
Sectors <sup>(1)</sup>	0 to 63	Displays the number of sectors/track.
Maximum capacity		Displays the maximum capacity of the hard drive.
Multi-sector transfers <sup>(1)</sup>	Disabled 2 sectors 4 sectors 8 sectors 16 sectors Auto*	Determines the number of sectors per block for multiple sector transfers.  Auto refers to the size the disk returns when queried.

*continued*

Menu Fields	Settings	Comments
<b>Primary/Secondary Master/Slave</b>		
LBA mode control	Enabled* Disabled	Enabling this option causes Logical Block Addressing (LBA) instead of cylinders and heads. Select <code>Disabled</code> for IDE hard disk drives that are up to 528 MB in size. When using an IDE drive larger than 528 MB and an operating system that supports LBA, select <code>Enable</code> . MS-DOS and Windows are examples of operating systems that support LBA.
32-bit I/O	Enabled* Disabled	Enables or disables the 32-bit, hard disk drive data transfer option. Enabling this option speeds up data transfers; ensure that the HDD supports 32-bit I/O transfers.
Transfer mode <sup>(1)</sup>	Standard* Fast PIO1 Fast PIO2 Fast PIO3 Fast PIO4	Selects the method to transfer data to and from the HDD. If you select the user autotype for the HDD, Setup automatically selects the optimum transfer mode.
Ultra DMA transfer mode <sup>(1)</sup>	Disabled Mode 0 Mode 1 Mode 2	Selects the Ultra DMA method to transfer data to and from the HDD.

<sup>(1)</sup> These fields are automatically filled in if the computer auto-detected an installed hard disk drive.

<sup>(2)</sup> Incorrect settings can cause the computer to malfunction.

*continued*

## BIOS Setup Utility

Menu Fields	Settings	Comments
<b>Memory and Cache:</b>		
External cache	Enabled* Disabled	Enables or disables the external cache.
System BIOS shadow	Enabled* Disabled	Always set to <code>Enabled</code> .
Cache system BIOS	Enabled* Disabled	This option enables the system BIOS to be cached in the external cache (if installed). This increases computer performance because BIOS instructions can be executed in cache instead of RAM.  <code>Enabled</code> is the recommended setting.
Video shadow	Enabled* Disabled	The main logic board reserves an area of DRAM for a copy of video BIOS ROM. This DRAM called "shadow memory" is write-protected and has the same addresses as the video BIOS ROM locations. When video BIOS ROM is shadowed, the ROM information is copied into an appropriate area in DRAM. This increases the computer's performance because the video BIOS instructions are in fast DRAM instead of ROM.  <code>Enabled</code> is the recommended setting.
Cache video BIOS	Enabled* Disabled	This option enables the video BIOS to be cached in the external cache (if installed). This increases computer performance because video BIOS instructions can be executed in cache instead of RAM.  <code>Enabled</code> is the recommended setting.
Shadow memory region C8000h: CC000h: D0000h: D4000h: D8000h: DC000h:	Enabled Disabled	Enables or disables shadowing of individual 16K segments of ROM to increase computer performance.  <b>CAUTION:</b> Some option ROMs do not operate properly when shadowed.

*continued*

Menu Fields	Settings	Comments
<b>Boot Options</b>		
NumLock	Auto* On Off	Turns NumLock on or off each time the computer boots.  If <code>Auto</code> is selected, the computer will turn on NumLock if it detects a numeric keypad.
Floppy check	Enabled* Disabled	Enabled permits verification of FDD type at boot. Disabled prevents FDD verification and speeds up the boot process.
Summary screen	Enabled* Disabled	Enabling this option causes the computer to display configuration parameters (in the form of a summary screen) during boot.
Quiet boot	Enabled* Disabled	Enables or disables the display of POST messages. Quiet Boot, when enabled, displays the DIGITAL logo, instead of POST messages.

*continued*

## Advanced

Menu Fields	Settings	Comments
<b>Peripheral Configuration</b>		
Serial Port A	PNP O/S Disabled Enabled Auto*	<p>Enables or disables onboard serial port A at the specified address.</p> <p>Select "Auto" unless interrupts IRQ4 and/or IRQ3 are allocated as a computer resource.</p> <p>Two devices cannot share the same IRQ. Choosing "Disabled" makes serial port A unusable. If you select "Auto," Setup configures COM1 = address 3F8h and IRQ = 4.</p> <p>If "Enabled" is selected, the address and IRQ are user-defined.</p> <p>"Auto" is the recommended setting.</p>
Base I/O Address	3F8* 2F8 3E8 2E8	Sets the base address for serial port A.
Interrupt	IRQ3 IRQ4*	Sets the interrupt for serial port A.
Serial Port B	PNP O/S Disabled Enabled Auto*	<p>Enables or disables onboard serial port B at the specified address.</p> <p>Select "Auto" unless interrupts IRQ4 and/or IRQ3 are allocated as a computer resource.</p> <p>Two devices cannot share the same IRQ. Choosing "Disabled" makes serial port B unusable. If you select "Auto", Setup configures COM2 = address 2F8h and IRQ = 3.</p> <p>If "Enabled" is selected, the address and IRQ are user-defined.</p> <p>"Auto" is the recommended setting.</p>
Base I/O Address	3F8 2F8* 3E8 2E8	Sets the base address for serial port B.

*continued*



Menu Fields	Settings	Comments
Interrupt	IRQ3* IRQ4	Sets the interrupt for serial port B.
Parallel Port	PNP O/S Disabled Enabled Auto*	<p>Enables or disables onboard parallel port at the specified address.</p> <p>Select "Auto" unless interrupts IRQ5 and/or IRQ7 are allocated as a computer resource.</p> <p>Two devices cannot share the same IRQ. Choosing "Disabled" makes the parallel port unusable. If you select "Auto", Setup configures the parallel port = address 378h and IRQ = 7.</p> <p>If "Enabled" is selected, the address and IRQ are user-defined.</p> <p>"Auto" is the recommended setting.</p>
Base I/O Address	378* 278 3BC	Sets the base address for the parallel port.
Interrupt	IRQ5 IRQ7*	Sets the interrupt for the parallel port.
Mode	Bi-directional* EPP ECP Output only	<p>Sets the onboard parallel port mode.</p> <p>Bi-directional is the PS/2 compatible mode and able to receive data.</p> <p>EPP is Enhanced Parallel Port mode. Only choose a mode that the parallel port device (such as a printer) supports. Check the parallel port device documentation for this information. If this information cannot be located, use the default setting.</p> <p>ECP is Extended Capabilities Port mode.</p> <p>Output only is Centronics-compatible.</p>
EPP Type	EPP 1.7 EPP 1.9	Selection based on what EPP version the printer supports. Choice is available only if EPP mode is selected.
DMA Channel	DMA 1 DMA 3*	Sets the DMA channel for the parallel port.
Floppy disk controller	Enabled* Disabled	Enables or disables the onboard diskette controller.

*continued*

## BIOS Setup Utility

Menu Fields	Settings	Comments
DMA Clock Select	1 Bus clock* ½ Bus clock	Selects the DMA clock.
USB Device	Enabled* Disabled	Enables or disables the USB device port.
Integrated PCI IDE	Disabled Primary Both*	Enables or disables the local bus IDE adapter. Both enables both the primary and secondary adapters. Primary enables only the primary adapter.
PS/2 Mouse	Enabled* Disabled	Enables or disables the PS/2 mouse. Selecting "Disabled" prevents any installed PS/2 mouse from functioning, but frees up IRQ12. Selecting "Enabled" allows the O/S to determine whether to enable or disable the mouse.
Video Share Memory	1M* 1.5M 2M 2.5M	Select the size of main memory allocated for video memory.
Secured Setup Configuration	Yes No*	Selecting "Yes" prevents a Plug and Play operating system from changing system settings.
Large Disk Access Mode	DOS* Other	Select DOS if you have MS-DOS installed. Select Other if you have another operating system installed.  A large disk drive constitutes one that has more than 1024 cylinders, 16 heads, or 63 tracks per sector.
Plug & Play O/S	Yes No*	Select "Yes" if you are using a Plug and Play capable operating system, such as Windows 95. Otherwise, select "No" if you need the BIOS to configure non-boot devices.
Reset Configuration Data	Yes No*	Select "Yes" if you wish to clear the System Configuration Data and reset to factory defaults.

## Security Options

Menu Fields	Settings	Comments
Set User Password	Press [Enter]	Allows a user password to be set.  This password can be set only if a supervisor password is entered.
Set Supervisor Password	Press [Enter]	Allows a supervisor password to be set.
Password on Boot	Enabled Disabled*	Enables or disables the enter password on boot option.  If this option is enabled, a user or supervisor password must be entered in order for the boot process to complete. If a user or supervisor password is not entered, the operating system cannot be accessed.
Fixed disk Boot Sector	Normal* Write Protect	Write protects the boot sector on the hard disk drive.
Diskette Access	Supervisor* User	Controls who has access to diskette drives.  If <code>Supervisor</code> is selected, access to the diskette drive is limited to the supervisor, who must enter his or her password. If <code>User</code> is selected, the diskette drive can be accessed by entering either the supervisor or the user password.  Whatever setting is chosen, it only becomes functional if both a <code>Supervisor Password</code> and a <code>User Password</code> have been set (if you choose <code>User</code> for the setting).

## Power

Menu Fields	Settings	Comments
Power Savings	Disabled Customized* Maximum Power Savings Maximum Performance	Enable this field to use any of the power savings options. If this field is enabled and the other fields are disabled, only minimal power reduction is affected.  Maximum Power Savings conserves the greatest amount of system power while Maximum Performance conserves power but allows greatest system performance. To alter these settings choose Customize. To turn off Power Savings, select Disable.
Standby Timeout	Off* 1 minute 2 minutes 4 minutes 6 minutes 8 minutes 12 minutes 16 minutes	After a set period of computer inactivity, the BIOS places the computer in a standby state (medium power savings), that is, the monitor and CPU are set to power savings. Any mouse or keyboard activity quickly returns the computer to operation.  Alternately, you can choose to disable this option and thereby not use this feature. Power savings must be enabled to use this option.
Auto Suspend Timeout	Off* 5 minutes 10 minutes 15 minutes 20 minutes 30 minutes 40 minutes 60 minutes	After a set period of computer inactivity, the BIOS places the computer in a suspended state (maximum power savings), that is, the monitor and fan are shut off and the CPU and hard disk are powered down. Any mouse or keyboard activity quickly returns the computer to operation.  If you set a timer for the field, you should also set Power Savings to Enabled.  Alternately, you can disable this option and not use this feature. Power Savings must be enabled to use this option.
Hard Disk Timeout	Disabled* 10 seconds 15 seconds 30 seconds 45 seconds 1 minute 2 minutes 4 minutes 6 minutes 8 minutes 10 minutes 15 minutes	After a set period of computer inactivity, the BIOS places the hard disk in inactive mode and powers it down. Any mouse or keyboard activity quickly returns the hard drive to operation.  In order for this feature to work, Power Savings must be enabled.  Alternately, you can choose to disable this feature.

*continued*

Menu Fields	Settings	Comments
Resume on Modem Ring	On Off*	Setting this feature to "On" wakes up the system when an incoming call is detected on the modem.
Resume on Time	On Off*	Setting this feature to "On" allows the system to perform certain HCT tests.
Power on Modem Ring	Enabled Disabled*	Enable or disable allows the user to select system power up when incoming call is detected on the modem.
Programmable Power-on	Enabled Disabled*	Enable or disable allows the user to set a specific time to power up.
Resume Date:	[mm/dd/yyyy]	Date setting for Programmable Power-on, if enabled.
Resume Time:	[00:00:00]	Time setting for Programmable Power-on, if enabled.
Activity Event		Selected Activity Events will cause timer reload or wakeup from power savings mode. An IRQ detected as system activity.
IRQ4	Enabled* Disabled	
IRQ5	Enabled Disabled*	
IRQ6	Enabled* Disabled	
IRQ7	Enabled Disabled*	
IRQ9	Enabled Disabled*	
IRQ10	Enabled Disabled*	
IRQ11	Enabled Disabled*	
IRQ12	Enabled* Disabled	
IRQ13	Enabled* Disabled	
IRQ14	Enabled* Disabled	
IRQ15	Enabled Disabled*	
NMI	Enabled Disabled*	

## Boot

Menu Fields	Settings	Comments
Boot Device Priority	<ol style="list-style-type: none"> <li>1. Diskette Drive*</li> <li>2. Hard Drive*</li> <li>3. ATAPI CD-ROM Drive*</li> </ol>	<p>The numbers refer to the order in which the devices are addressed for the system files needed to boot the system.</p> <p>To change the order, use the ↑ or ↓ cursor keys to select the device you want to move. Then use the + and - keys, on the numeric keypad, to move the device to the desired boot order.</p>
Hard Drive	<p>List of available bootable devices, for example,</p> <ol style="list-style-type: none"> <li>1. IDE Hard Drive</li> <li>2. Bootable ISA Card</li> </ol>	<p>To change the order, use the ↑ or ↓ cursor keys to select the device you want to move. Then use the + and - keys, on the numeric keypad, to move the device to the desired boot order.</p>

## Flash Utility

DIGITAL PC 3010 computers have BIOS software in a read-only, non-volatile memory (ROM) chip. This BIOS initializes hardware and boots the operating system when the computer is turned on. The BIOS also provides access to other services such as keyboard and disk drives.

The computer comes equipped with flash memory. This means that you can restore the computer's BIOS simply by running the flash utility. If necessary, you can also upgrade the computer's BIOS to future releases by running the flash utility along with any flash BIOS update diskette.

You can download BIOS updates along with the flash utility and instructions on how to flash the computer's BIOS from the Internet or DIGITAL's Bulletin Board Service (BBS).

# System Software **3**

---

## Introduction

Your computer comes with the Windows 95 or Windows NT Workstation operating system and the necessary device drivers pre-installed on your hard disk drive. The operating system, utilities, and device drivers are optimized for your computer's configuration and are ready for use.

This chapter describes:

- The software and documentation that you receive on your hard disk drive
- The operating system software kit
- The DIGITAL System Software CD and supplied software diskette
- Configuring system parameters
- How to use your diagnostic software
- How to restore your hard disk drive software using the supplied backup CD-ROM
- Other device drivers
- How to get updates



## Factory Installed Software

Included with your DIGITAL PC are software products, utilities, and on-line documentation. In the following sections you can read about the DIGITAL-installed software as well as the contents of the DIGITAL System Software CD and how to install these applications onto your hard disk drive.

The following table describes the software installed on your hard disk drive:

<b>Software</b>	<b>Description</b>
Operating system	Either Windows 95 or Windows NT Workstation. Associated on-line documentation is included with the operating system.
Device drivers	These can include drivers, such as video, mouse, and IDE, that you need for your computer. Some configurations also include audio, network, CD-ROM, or SCSI drivers.

## DIGITAL System Software CD

Included in your accessories is the DIGITAL System Software CD. This CD contains the following items:

<b>Item</b>	<b>Description</b>
DIGITAL on-line documentation	User guides and text files that explain how to operate your computer.
Software applications	Software products that will help you to obtain the most benefit from your DIGITAL computer.
Device drivers	Drivers that are needed for proper computer functions.
Troubleshooting utilities	Utilities that will aid in troubleshooting the computer when it's experiencing problems.
Diagnostic diskette images	Images to create diagnostic diskettes that can then be used in the event that your computer fails to boot.

This CD does not contain the operating system. See CD-INFO.TXT on the CD for non-operating system installation and configuration information. Use the "DIGITAL System Software CD Installation Program" (described below) to install the applications, utilities, documentation, and drivers on the hard disk drive.

## DIGITAL System Software CD Installation Program

The DIGITAL System Software CD includes an easy-to-use program that allows you to install the supplied applications and drivers onto your computer's hard disk drive.

To launch the installation program:

1. Insert the DIGITAL System Software CD into the CD-ROM drive.
2. Click the Start button and then click Run.
3. Type `D:\SETUP.HTM` in the Open box (where D:\ is your CD-ROM drive).
4. Click OK.
5. The installation program will be launched and you will have the opportunity to select what items on the CD you wish to install.



**NOTE:** If your computer does not have an installed CD-ROM drive, please ask your Network Administrator about accessing the DIGITAL System Software CD via the network.

## On-Line Documentation

DIGITAL provides an on-line resource library for all available product information. The resource library may include Windows-based help files, electronic reference guides, and Readme files. Electronic reference guides are available in Adobe Portable Document Format (PDF). These documents can be displayed and printed exactly as the original. The Adobe Acrobat Reader is provided on the DIGITAL System Software CD and can be easily installed on your hard disk drive.

The following table lists the on-line documentation available for your computer. These files can be installed from the DIGITAL System Software CD.

On-Line Documentation	Description
<i>System Reference</i>	The on-line System Reference guide describes how to operate, upgrade, and configure your computer. You can view and print the guide using the Adobe Acrobat Reader.
README.TXT	README.TXT files help you set up, operate, and configure your computer. DIGITAL recommends that you read this information first.
CD-INFO.TXT	This text file provides details on what can be found on the CD and how to install these items onto your computer's hard disk drive.

There are other on-line documentation files available. Many of these relate to specific applications. Check the application program folder. Also check the applications themselves for the on-line help that is integrated into the applications.

## Applications

Your DIGITAL PC 3010 ships with several applications designed to make your computer easier to use. The following table lists the software that is available for your computer. Unless stated otherwise, all applications are on the System Software CD and can be installed on your computer's hard disk drive using the "DIGITAL System Software CD Installation Program."

<b>Applications</b>	<b>Description</b>
ClientWORKS	ClientWORKS is DIGITAL's client management software designed to help network administrators lower the total cost of ownership by automating asset management tasks and managing computers remotely.
Diagnostics	Diagnostic diskette images have been provided on the DIGITAL System Software CD with your computer. Once created, these diskettes can be used to troubleshoot your computer if you are unable to access the software through Windows 95 or Windows NT. DIGITAL recommends that you create these diskettes as soon as possible. For instructions, see the CD-INFO.TXT file on the DIGITAL System Software CD.
PC Care	PC Care is a diagnostic, computer information, and computer optimization tool. (See "Using Diagnostics.")
S.M.A.R.T. Monitor	If your computer's hard disk drive is S.M.A.R.T. aware, DIGITAL's S.M.A.R.T. Monitor will keep you apprised as to how your hard disk drive is operating.
Adobe Acrobat Reader	The Adobe Acrobat Reader software allows you to read and print electronic documents.
Desktop Wellness	A tutorial that contains ergonomic information to assist you to work comfortably. This tutorial can be used to find aspects of your tasks and work environment that can be adjusted to suit your needs.

## DIGITAL Startup Diskette

A DIGITAL Startup Diskette is included with your accessories. In the event that you are unable to access your computer's operating system, you can use this diskette to boot the computer and access the CD-ROM drive. The instructions for the DIGITAL Startup Diskette will guide you through steps to create a Windows 95 bootable Setup/Restore diskette and four diagnostic diskettes. The Windows 95 Setup/Restore diskette is needed in order to restore the Windows 95 operating system. The diagnostic diskettes can be used to troubleshoot your computer if you are unable to access Windows 95.

## Operating System Kit

Your DIGITAL PC 3010 comes with an operating system kit, which matches the operating system installed on your computer's hard disk drive. You receive one of the following:

<i>Windows 95</i>	Windows 95 CD-ROM, software license, and the manual. <i>Introducing Microsoft Windows 95</i> describes how to use the Windows 95 operating system.
<i>Windows NT Workstation</i>	Windows NT Workstation: CD-ROM, setup diskettes, software license. <i>Microsoft Windows NT Installation Guide</i> and other documentation. <i>Microsoft Windows NT Installation Guide</i> describes how to install and use Windows NT, including information about additional networking services that you can install.

The CD-ROM and setup diskettes are for restoring your operating system. Be sure to put them away in a safe place.

# Integrated Desktop Manageability

## ClientWORKS

ClientWORKS, DIGITAL's client management software, contains a powerful set of utilities designed to help you get the most out of your networking environment. Based on the desktop Management Interface (DMI) industry-standard, ClientWORKS reduces total cost of ownership and makes DIGITAL PCs more manageable than the competition. Included, at no charge, on all new DIGITAL PC 3010 computers, ClientWORKS saves MIS personnel time, reduces travel costs when diagnosing remote PCs, and improves accuracy of analysis of clients on the network.

ClientWORKS includes:

- Enhanced 32-bit DMI service layers for Windows 95 and Windows NT, and a 16-bit service layer for Windows for Workgroups.
- DIGITAL's enhanced system Management Information Format (MIF) file for industry-standard desktop management.
- Enhanced ClientWORKS browser, offering identification of DMI components, both locally and remotely.
- SNMP agent software, including a MIF-to-MIB converter for powerful remote management in heterogeneous environments.
- MIFMAKER, DIGITAL's unique utility designed to make DMI data available to Microsoft Systems Management Server (SMS).
- Diagnostics for enhanced system troubleshooting.

ClientWORKS comes on the DIGITAL System Software CD. For installation instructions, see "DIGITAL System Software CD Installation Program." ClientWORKS includes SNMP subagents that make your computer visible to an SNMP console. Although these subagents are pre-installed, they are disabled in the factory-installed software. Before you can enable the subagents, you must first install TCP/IP, which is part of Windows 95. To install TCP/IP, follow the Windows 95 help instructions for installing a network protocol. Once you have installed TCP/IP, you must install the Microsoft SNMP Master Agent. For installation instructions, refer to the ClientWORKS online help and user documentation.

*For additional information, including last-minute release notes, please see the README.TXT and RELNOTES.TXT files in the ClientWORKS folder on your DIGITAL PC 3010 computer.*

## **Self Monitoring Analysis Technology (S.M.A.R.T.)**

If your DIGITAL PC 3010 hard disk drive is S.M.A.R.T. aware and you are running Windows 95, DIGITAL S.M.A.R.T. Monitor will keep you apprised as to how your hard disk drive is operating. S.M.A.R.T. Monitor is included as part of ClientWORKS and will be installed when ClientWORKS is installed.

Once installed, S.M.A.R.T. Monitor is launched when Windows 95 starts and then immediately minimized, the icon placed in the toolbar. The S.M.A.R.T. aware drive is periodically polled to monitor the performance of the motors, media, heads, and electronics of the drive. If problems are detected, you will be notified and advised to take appropriate action. By clicking on the icon at any time, you can review the status and history of any S.M.A.R.T. devices. You can also modify the setup of DIGITAL S.M.A.R.T. Monitor.

*For more information, refer to your ClientWORKS and/or System Reference documentation.*

## Configuring System Parameters

Although your computer is operation ready, you may need to change the video configuration or configure a network. You may also want to add some additional hardware. The available software can help you with these tasks as explained in the following subsections.

### Configuring Video

Your DIGITAL PC 3010 computer supports Display Data Channel (DDC 1/2b) specifications. DDC technology offers true auto-configuration by providing a direct communications link between the monitor, onboard video circuitry, and the operating system. Full DDC capability requires DDC support by all computer components. DDC will automatically set the video parameters for optimum monitor resolution. If your monitor does not include DDC support, then you may need to change the default video settings.

If you need to change the default settings, use the Control Panel Display option. However, before changing the resolution or resetting your monitor type, please check your monitor documentation. You must make your selections based on what your monitor can support. Choosing one of the Factory Preset Resolutions listed in your monitor manual allows you to change the resolution without having to adjust the monitor.

*Refer to the Windows 95 User's Guide or the Windows NT Workstation Installation Guide and any related on-line help for configuration information.*



## Configuring Additional Hardware

Adding additional hardware requires configuring your computer resources, such as IRQ and DMA settings. With a Plug and Play operating system, such as Windows 95, and Plug and Play hardware, the process is simplified. Windows 95 can automatically determine the appropriate resource settings and then set them.

Some boards are not Plug and Play. These are known as "legacy" boards. Windows 95 can also handle these.

*See your Microsoft Windows 95 documentation for information on configuring new hardware.*

Other operating systems, such as Windows NT Workstation, require that you select and set the configurations. The ICU diskette (available as a diskette image on the DIGITAL System Software CD) can help you determine the available resources. Before installing the new board, insert the diskette into drive A and power on your computer.

*See "CD-INFO.TXT" file on the DIGITAL System Software CD for information on creating the ICU diskette.*

*See the ICU on-line help for complete instructions.*

## Using Diagnostics

There are a variety of software diagnostic products provided with your DIGITAL PC 3010 computer. If you are using Windows 95, the PC Care diagnostic software is provided on the DIGITAL System Software CD. You can use this software to troubleshoot your computer. For installation instructions, see "DIGITAL System Software CD Installation Program."

If you are a Windows NT Workstation user, your factory installed software includes Windows NT Diagnostics. You can use this software to troubleshoot your computer by choosing Administrative Tools from the Programs menu and then selecting the Windows NT icon.

Both Windows 95 and Windows NT users also receive diagnostic diskette images on the DIGITAL System Software CD. DIGITAL recommends that you create these diskettes as soon as possible (for instructions on this, see the CD-INFO.TXT file on the CD-ROM).

Once created these diskettes can be used to examine the computer's current configuration, locate faulty components, and troubleshoot problems. If the hard disk drive fails to boot or you are unable to access the diagnostic software from Windows 95 or Windows NT Workstation, proceed as follows:

1. Insert the diagnostics diskette labeled "For Emergency Use" into your diskette drive and power on your computer.
2. Once the program begins, follow the instructions displayed on your monitor screen.

Windows 95 users may also want to install the diagnostic software on their hard disk drive.

*See the applicable README.TXT file on each of the Diagnostics diskettes for installation instructions and for additional information about the Diagnostics package.*

## Restoring Your Software

In the event of a hard disk failure or if your computer software becomes corrupted, you need to reinstall your operating system, device drivers, and any other utilities or applications. At other times you may only need to replace a driver or an application that was accidentally deleted or corrupted.

Before you begin the installation, make sure you have the operating system kit supplied with your computer, the DIGITAL System Software CD, and any other applications you may have installed on your computer.

## System Software

The following instructions are for a complete restoration of your computer software.

1. If possible, back up data and any applications.
2. Reformat the hard disk drive, if necessary. You need to reformat your hard disk drive if it completely failed or if you replaced it with a new one.
3. Install the operating system.

*Refer to the supplied Windows 95 and Windows NT Workstation documentation for additional information.*

4. Install the necessary device drivers (see "DIGITAL System Software CD Installation Program").

*For additional installation and configuration information, refer to the CD-INFO.TXT file on the DIGITAL System Software CD.*



**NOTE:** Device drivers are often subject to change. You can find the latest device drivers using the Internet or through DIGITAL's Bulletin Board service (See "Latest Product Information and Update").

5. Install the DIGITAL supplied applications, such as ClientWORKS.

These applications are located on the DIGITAL System Software CD, (see "DIGITAL System Software CD Installation Program").

6. Install your applications.

If you only need to reinstall a device driver or an application, you can do so by following step 4 or 5, whichever is relevant.

## Additional Device Drivers

Most of the device drivers you need are installed at the factory. However, you may need to install additional device drivers for options that were not factory installed. DIGITAL provides all the factory-installed device drivers and additional device drivers on the supplied CD-ROM. IDE, CD-ROM, and video device drivers are some of the drivers available for the following operating systems:

- Windows 95
- Window NT
- Windows for Workgroups



**NOTE:** Not all device drivers on the CD-ROM are supported by DIGITAL. These device drivers are supplied for your convenience only.

See the file CD-INFO.TXT on the System Software CD-ROM for configuration and installation information.

## Initial Troubleshooting

The following sections provide initial troubleshooting procedures and tables listing specific problems, probable causes, and recommended actions to take if the computer fails after configuring it or after installing optional hardware or software.

*Refer to the documentation supplied with the additional options if problems are encountered after installation.*

- Keep it simple, only troubleshoot one problem at a time. Also, only make one change at a time. For example, if the IDE hard disk drive fails to boot, do not try all the suggested actions at once. Instead, start with one suggestion such as checking the cables. After securing the cables, try booting the computer. If it does not work, try another suggestion.
- Look for abnormal computer, keyboard, and monitor LED indications. For example, make sure the power on LED lights when you turn on the computer and the drive access indicators light when using either the diskette drive or hard disk drive.
- If there are Power On Self Test (POST) error(s), run the BIOS Setup utility and fix the problem(s) identified by the POST error(s).
- If you installed external devices, make sure all cables are correctly connected to the appropriate devices.
- If you installed devices inside the computer, make sure nothing was bumped or jarred loose, and that all cable connections are securely in place.

## Troubleshooting

- Make sure all device drivers are installed correctly.
- If the computer hangs, soft boot the computer (press the [Ctrl] + [Alt] + [Del] keys). If the computer fails to boot, turn it off, wait until all disk drives completely spin down, and then turn it back on.
- Pay close attention to any error message that appears on the screen.

If the error message is computer related, refer to the “Error Messages” section at the end of this chapter.

If the error message is Windows related, refer to any on-line help and the appropriate Windows documentation supplied with the computer.

- Listen carefully for computer errors in the form of beeps. Record the number of beeps and their pattern then refer to the “Beep Codes” section at the end of this chapter.
- README files might be factory installed, on the DIGITAL System Software CD, or as printed material. This README information can help you setup, configure, and operate the computer.
- Run the diagnostics software. Refer to the following section for information on accessing and running the supplied diagnostics program.
- If the computer will not boot into Windows, use the Emergency Repair Disk you created during setup to gain access to the computer’s hard disk drive. Afterwards, troubleshoot the computer using the information in this guide and correct any problems.

## Pass/Fail Criteria

As a Final Acceptance Test, the following tests should be run to meet the Pass/Fail criteria:

1. **Successful completion of the POST tests.**
2. **Successful completion of the following AMI module tests (one pass):**

System Board	(All Tests)
Memory	(All Tests)
Video	(All Tests)
Hard Disk	(All Tests except: sequential write/read and sequential write/random read)
Floppy Disk	(All Tests)
Keyboard	(All Tests)
COM Port	(All Tests)
LPT Ports	(All Tests)
Pointer Device	(All Tests)

3. **Successful bootstrap of the computer installed operating system.**

Operating systems supported:

- Windows 95
- Windows NT Workstation

## Diagnostics

Computers with the Windows 95 operating system installed have PC Care diagnostics software factory installed on the hard disk drive. Use this software to troubleshoot the computer.

Computers with the Windows NT Workstation operating system have factory installed software that includes an Administrative Tools group in the Program Manager menu. This program group includes a Windows NT Diagnostics icon for launching the Diagnostic software. Use this software to troubleshoot the computer.

The diagnostic diskettes (that can be created from images on the DIGITAL System Software CD) can be used to examine the computer's current configuration, locate faulty components, and troubleshoot the computer if you are unable to access the diagnostic software from Windows 95 or Windows NT Workstation.



**NOTE:** For instructions on creating the diagnostic diskettes, refer to the CD-INFO.TXT file on the DIGITAL System Software CD.

To access the diagnostic software:

1. Insert the "For Emergency Use" diskette into the diskette drive and then type:

```
A:\AMIDIAG
```

2. If you are unable to boot from the hard disk drive, you can instead boot directly from the "For Emergency Use" diskette.
3. Once the program begins, follow the instructions displayed on the monitor screen.

*Refer to the README file on the "For Emergency Use" diskette for additional information.*



## DIGITAL ClientWORKS and DMI

ClientWORKS is a Desktop Management Interface (DMI) based software application that has been developed by Digital Equipment Corporation.

ClientWORKS for Windows 95 and Windows NT Workstation can be used to help you, the system manager, or system administrator to identify the computer's current hardware configuration. This feature is useful, for example, if you need to see if you have sufficient memory or a large enough hard disk drive for the applications you want to run. System managers or system administrators can access ClientWORKS data through Simple Network Management Protocol (SNMP) consoles. This feature means the company can protect its current investment in SNMP software and network monitors. Other features include:

- If there is a known computer component that needs to be replaced, under Windows 95 or Windows NT Workstation, a system manager or administrator can access ClientWORKS and get the Field Replaceable Unit (FRU) part number. This part number can then be relayed to the service provider to expedite ordering.
- Serial numbers can easily be identified to obtain warranty service.
- The amount and type of computer memory you have installed can easily be identified using ClientWORKS. This is especially useful if you need to know the computer's capabilities prior to loading software.
- A system manager or administrator can use ClientWORKS to remotely access computer configurations that are attached to a network. This feature enables a system manager or administrator to easily maintain an accurate equipment log.

*Refer to the supplied ClientWORKS factory installed on-line help or the DIGITAL System Software CD for detailed information on using or installing either program.*

## **Self Monitoring Analysis Technology (S.M.A.R.T.)**

If the computer's hard disk drive is S.M.A.R.T. aware and you are running Windows 95, DIGITAL's S.M.A.R.T. Monitor will keep you apprised as to how the hard disk drive is operating.

When Windows 95 starts, DIGITAL S.M.A.R.T. Monitor is launched and then immediately minimized, placing the icon in the Windows 95 taskbar. DIGITAL S.M.A.R.T. Monitor then periodically polls the S.M.A.R.T. aware devices in the computer and by clicking on the icon, you can review the status of these devices. You can also review general information, the history of the drives, and modify the setup of DIGITAL S.M.A.R.T. Monitor.

If problems are detected in the computer's devices, a dialog box will appear displaying an error message.

For more information on DIGITAL S.M.A.R.T. Monitor, refer to the System Reference, ClientWORKS, and/or System Software documentation.

## Advanced Troubleshooting

DIGITAL has a Customer Replaceable Unit (CRU) process during the warranty period for:

- DIGITAL monitors with screens less than 20 inches
- Mice
- Keyboards
- Speakers
- Other parts as defined by DIGITAL as CRUs

The DIGITAL CRU process provides for overnight shipment of the part directly to the customer site. The Service provider gives the customer instructions for installing the replacement unit and for returning the defective part. Customers are billed for the specified part if they fail to return the part to DIGITAL within ten days of the replacement unit shipment.

In the following troubleshooting tables, “CRU Process” means that when a process is determined to be broken, the Service provider should use the previously-described CRU process.



**NOTE:** The following troubleshooting suggestions are not in any specific order. They are merely a list of possible problems and solutions.

## Computer Troubleshooting

<b>Problem</b>	<b>Possible Cause</b>	<b>Action</b>
No response when the computer is turned on.	Computer is not plugged in.	Turn off the computer, plug it in, and then turn it back on again.
	No power at the wall outlet.	Use another wall outlet.
	Main logic board failure.	Replace the main logic board.
	Main logic board jumpers incorrectly set.	Set all appropriate jumpers (Refer to the computer's <i>System Reference</i> guide).
	CPU has failed.	Replace the CPU.
	Power supply has failed.	Replace the power supply.
Power is on, screen is on, but the computer does not respond.	Voltage select switch is set incorrectly.	Make sure the setting on the back of the computer matches the country's voltage requirements. Refer to the supplied <i>Quick Setup</i> guide for more information.
	Keyboard not connected, mouse not connected, or both might be in the wrong port.	Connect the keyboard and/or mouse. If already connected, confirm that each device is in the appropriate port.
Power is on, but there is no screen display.	Brightness and contrast controls are not correctly set.	Adjust the brightness and contrast controls.
	Monitor is in power saving mode.	Make sure the power light on the monitor is green. If not, and the Power Saving light is lit, press the [Shift] key to reactivate monitor.
	Monitor is off.	Turn on the monitor.
	Monitor cable is incorrectly installed.	Check all monitor connections.
	Incorrect video drivers installed.	Install the correct video drivers.
	Video controller has failed.	Replace the main logic board.
	Monitor has failed.	Try another monitor. If the new monitor operates correctly, replace the old monitor following the Customer Replacement Unit process described in the <i>Warranty and Information</i> booklet.

*continued*

Problem	Possible Cause	Action
Computer operates incorrectly after installing an optional expansion board.	Expansion board installed incorrectly.	Remove the expansion board and reinstall.
	Did not run the ISA Configuration Utility (ICU) to configure a non-Plug and Play expansion board before installation.	Run the ICU to properly configure expansion board and then reboot the computer. Refer to any supplied ICU, Windows 95, and Windows NT Workstation documentation.
	<b>Note:</b> Plug and Play expansion boards are automatically configured. Expansion board has failed.	Remove expansion board and reboot. If computer boots without errors, replace expansion board.
Computer operates incorrectly after installing optional DIMMs.	DIMMs installed incorrectly.	Remove DIMMs and reinstall.
	DIMMs have failed.	Replace DIMMs.
Computer fails to retain setup information.	Computer battery has failed.	Replace computer battery.
	Discharge CMOS jumper set to "Discharge."	Set discharge CMOS jumper to "Normal." Refer to the computer's <i>System Reference</i> guide.
Computer displays HIMEM.SYS errors.	Unstable memory at the specified address.	Run diagnostics.
		Replace faulty DIMM(s).
Computer displays an illegal action message (Windows 95).	Insufficient computer resources for a given operation.	Close all unnecessary applications.
		Close and restart Windows 95.
		Reboot computer.
Computer displays a System Error F002 message (Windows NT Workstation)	Faulty hardware.	Run the supplied diagnostic software to identify the faulty hardware. Replace the faulty hardware.

*continued*

## Troubleshooting

<b>Problem</b>	<b>Possible Cause</b>	<b>Action</b>
"Couldn't Find NTLDR" (Windows NT Workstation)	NTLDR file is missing from the root directory of the hard disk drive.	<p>Copy the NTLDR file to the hard disk drive's root directory.</p> <p>If using the supplied Windows NT Workstation CD-ROM disk, make the CD-ROM the current drive and then type:</p> <pre>copy\i386\ntldr c:\</pre> <p>at the command line prompt.</p> <p>If using the supplied Windows NT Workstation Setup disks, insert Setup Disk #2 into the diskette drive and then type:</p> <pre>expand ntldr.\$ C:\ntldr</pre> <p>at the command line prompt.</p>
"Error 000001E" (Windows NT Workstation)	The hard disk drive might have corrupted system files.	<p>Run chkdsk on the hard disk drive to correct any corrupted files. Also make sure the optional hardware is on the supplied <i>Microsoft Windows NT Hardware Compatibility List</i>.</p>

*continued*

Problem	Possible Cause	Action
"Error 0x00000069 or 0x00000067" (Windows NT Workstation)	Windows NT Workstation unable to communicate with the computer's hard disk drive controller.	<p>Using the BIOS Setup utility, slow down the DMA transfer rate of the controller.</p> <p>Make sure both ends of the SCSI bus are terminated.</p> <p>Make sure there are no IRQ or memory address conflicts.</p> <p>Make sure NTDETECT.COM is in the root directory of the boot drive partition.</p> <p>Make sure there are no missing Windows NT Workstation system files.</p> <p>Reload the Windows NT Workstation operating system files.</p>
"NMI Hardware Error" (Windows NT Workstation)	Faulty hardware.	<p>Make sure all main logic board SIMMs, DIMMs, CPU, VRM, video memory, and expansion board connectors are clean and properly seated in their respective sockets.</p> <p>Run the supplied diagnostic software to identify the faulty hardware. Replace the faulty hardware.</p>
Services or subsystems do not start properly (Windows NT Workstation)	Improper configuration, files missing or files not installed.	<p>Use the <i>Services</i> or <i>Devices</i> icons in the <i>Control Panel</i> menu to check for status. Also, check the system log in the <i>Event Viewer</i> for entries relating to the problem.</p>

*continued*

## Troubleshooting

<b>Problem</b>	<b>Possible Cause</b>	<b>Action</b>
Computer does not boot from an IDE hard disk drive.	IDE drive type incorrect.	Run the BIOS Setup utility to identify the correct drive type.  See drive type label on drive or consult drive documentation.
	Loose cable connectors.	Secure all cable connections.
	Onboard IDE interface disabled.	Run the BIOS Setup utility and set the Local Bus IDE Adapter to "Primary," "Secondary", or "Both."
	Hard disk boot sector is missing.	Repartition and reformat the hard disk drive.  <b>Caution:</b> This procedure erases what is currently on the hard disk drive.  You might want to try repairing the hard disk drive using a disk drive repair utility. Disk drive repair utilities can be purchased from the local software supplier.  If you do repartition and reformat the hard disk drive, proceed as follows for DOS-based operating systems such as Windows 95 and Windows NT Workstation.  Boot from a DOS diskette then enter the following commands:  <pre>c : cd \dos fdisk</pre> Follow the instructions on the monitor screen to create a new hard disk boot sector.
	There might be a boot sector virus.	Run anti-virus software.

*continued*



<b>Problem</b>	<b>Possible Cause</b>	<b>Action</b>
Computer does not boot from an IDE hard disk drive.	IDE hard disk is connected to the wrong IDE connector.	Connect the boot disk to the primary IDE connector on the backplane.
	Operating system software is not installed on the IDE hard disk drive.	Install the appropriate operating system.
	IDE hard disk drive is not correctly formatted or the requested partition does not exist.	Format the IDE hard disk drive or partition the IDE hard disk drive using the supplied operating system software.
	There is no software on the requested partition.	Install software on the requested partition.
	IDE hard disk drive jumpers incorrectly set.	Refer to the supplied IDE hard disk drive kit installation instructions.
	IDE hard disk drive has failed.	Replace the IDE hard disk drive.
	IDE hard disk drive ribbon cable has failed.	Replace the ribbon cable.
	IDE controller has failed.	Replace the backplane.
Computer does not recognize an internal or external SCSI hard disk drive or device.	SCSI device jumpers incorrectly set.	Refer to the supplied SCSI device kit installation instructions.
	SCSI ID conflicts.	Refer to the supplied SCSI device kit installation instructions on setting SCSI IDs.
	Terminating resistors not removed from the SCSI device.	Remove terminating resistors. Refer to the supplied kit installation instructions.
	SCSI option not enabled in BIOS Setup utility.	Run the BIOS Setup utility and enable SCSI option.
	SCSI cable not terminated.	Terminate each end of the SCSI cable.
	SCSI device not plugged in.	Check power and SCSI cables.
	Loose cable connectors.	Secure all cable connections.

*continued*

## Troubleshooting

<b>Problem</b>	<b>Possible Cause</b>	<b>Action</b>
Computer does not recognize an internal or external SCSI hard disk drive or device.	Hard disk boot sector is missing.	Repartition and reformat the hard disk drive.  <b>Caution:</b> This procedure erases what is currently on the hard disk drive.  You might want to try repairing the hard disk drive using a disk drive repair utility. Disk drive repair utilities can be purchased from the local software supplier.  If you do repartition and reformat the hard disk drive, proceed as follows for DOS-based operating systems such as Windows 95 and Windows NT Workstation.  Boot from a DOS diskette then enter the following commands:  <pre>c : cd \dos fdisk</pre> Follow the instructions on the monitor screen to create a new hard disk boot sector.
	There might be a boot sector virus.	Run anti-virus software.
	Loose cable connectors.	Secure all cable connections.
	SCSI adapter has failed.	Replace the SCSI adapter.
	SCSI ribbon cable has failed.	Replace the ribbon cable.
	SCSI device has failed.	Replace the SCSI device.

*continued*

Problem	Possible Cause	Action
Computer does not boot from an internal SCSI hard disk drive.	Computer not configured for SCSI hard disk drive operation.	Run the BIOS Setup utility and set the IDE controller option to "Disabled." This disables the onboard IDE interface.  <b>Note:</b> If you have both IDE and SCSI hard disk drives installed, the computer uses the IDE hard disk drive as the boot device.
	Operating system software is not installed on the SCSI hard disk drive.	Install the appropriate operating system.
	Requested partition does not exist.	Partition the SCSI hard disk drive and then reload the operating software.
	Loose cable connectors.	Secure all cable connections.
	SCSI adapter has failed.	Replace the SCSI adapter.
	SCSI ribbon cable has failed.	Replace the ribbon cable.
	SCSI hard disk drive has failed.	Replace the SCSI hard disk drive.

*continued*

## Troubleshooting

<b>Problem</b>	<b>Possible Cause</b>	<b>Action</b>
Computer does not boot from a target diskette drive.	Onboard diskette controller disabled.	Run the BIOS Setup utility and set the diskette controller option to "Enabled."
	Diskette drive not enabled.	Run the BIOS Setup utility to enable the diskette drive.
	BIOS Setup diskette write option enabled.	Enter the user password. If a supervisor password is required, see the system supervisor or system manager.
	Incorrect diskette drive type.	Run the BIOS Setup utility and select the correct drive type.
	Diskette boot option disabled.	Run the BIOS Setup utility and set the proper boot sequence.
	Diskette might not be bootable.	Use a bootable diskette.
	Diskette does not contain start-up files.	Insert a diskette with the correct start-up files.
	Diskette drive is empty.	Insert a diskette that contains an operating system.
	Diskette is worn or damaged.	Try another diskette.
	Loose cable connectors.	Secure all cable connections.
	Diskette access requires a supervisor password.	See the supervisor or system manager.
	Diskette access requires a user password.	Enter the user password.

*continued*

<b>Problem</b>	<b>Possible Cause</b>	<b>Action</b>
No response to keyboard commands.	Keyboard is password protected.	Enter the keyboard password.
	Keyboard is not connected.	Power down the computer and connect the keyboard.
	Keyboard is connected to the mouse port.	Power down the computer and connect the keyboard to the keyboard port.
	Computer operation halted.	Reboot computer.
	Keyboard has failed.	If available, try another keyboard. If the new keyboard operates correctly, replace the old keyboard following the Customer Replacement Unit process described in the <i>Warranty and Information</i> booklet.
	Keyboard controller has failed.	Replace the main logic board.

*continued*

## Troubleshooting

<b>Problem</b>	<b>Possible Cause</b>	<b>Action</b>
Keyboard keys type incorrectly.	Incorrect language selected.	Select the correct language.
	Keyboard has failed.	If available, try another keyboard. If the new keyboard operates correctly, replace the old keyboard following the Customer Replacement Unit process described in the <i>Warranty and Information</i> booklet.
No response to mouse activity.	Mouse is not connected.	Power down the computer and connect the mouse.
	Mouse is connected to the keyboard port.	Power down the computer and connect the mouse to the mouse port.
	Computer operation halted.	Reboot computer.
	Mouse driver not installed.	Install the appropriate mouse driver. Refer to the supplied application software documentation.
	Onboard mouse controller disabled.	Run the BIOS Setup utility and set the mouse port option to "Enable."
	Mouse has failed.	If available, try another mouse. If the new mouse operates correctly, replace the old mouse following the Customer Replacement Unit process described in the <i>Warranty and Information</i> booklet.
	Mouse controller has failed.	Replace the main logic board.
Mouse sticks.	Dirty mouse ball.	Remove the mouse ball and clean it. Also clean the rollers.

## Disk Drive Troubleshooting

Problem	Possible Cause	Action
IDE/SCSI hard disk drive cannot read or write information.	Incorrect disk drive jumper settings.	Refer to the supplied kit installation instructions.
	Loose or incorrectly installed cables.	Make sure all cables are correctly installed.
	IDE/SCSI hard disk drive is not correctly formatted or partitioned.	Format and partition as required using the supplied operating system.
	IDE drive type incorrect.	Run the BIOS Setup utility to identify the correct drive type.
	Onboard IDE interface disabled.	Run the BIOS Setup utility and set the Local Bus IDE Adapter to "Both."
	IDE/SCSI hard disk drive has failed.	Replace the IDE/SCSI hard disk drive.
	IDE/SCSI controller has failed.	Replace the backplane.
IDE/SCSI ribbon cable has failed.	Replace the ribbon cable.	

*continued*

## Troubleshooting

<b>Problem</b>	<b>Possible Cause</b>	<b>Action</b>
Target diskette drive cannot read or write information.	Diskette is not formatted.	Format the diskette.
	Diskette is worn or damaged.	Try another diskette.
	Diskette is write-protected.	Slide the write-protect switch so the hole is not visible (3½-inch diskette) or uncover the write-protect notch (5¼-inch diskette).
	Diskette drive is empty.	Insert a diskette.
	Onboard diskette controller disabled.	Run the BIOS Setup utility and set the diskette controller option to "Enabled".
	Diskette write protection is enabled.	Run the BIOS Setup utility and set the diskette write protection to "Disabled."
	Loose cable connectors.	Secure all cable connections.
	Diskette drive has failed.	Replace the diskette drive.
	Diskette drive controller has failed.	Replace the backplane.
	Diskette drive ribbon cable has failed.	Replace the ribbon cable.
Target diskette drive does not format diskettes.	Diskette access requires supervisor password.	Reboot computer and enter supervisor password. Afterwards, run BIOS Setup utility and set "Diskette Access" option to "User."
	Diskette write protection is enabled.	Run the BIOS Setup utility and set the diskette write protection to "Disabled."
	Diskette drive has failed.	Replace the diskette drive.



## Monitor Troubleshooting

Problem	Possible Cause	Action
Monitor power indicator is not on.	Monitor is turned off.	Turn on the monitor.
	Power cord is not connected.	Connect the power cord to the computer.
	No power at wall outlet.	Use another outlet.
	Monitor is in power saving mode.	Make sure the power light on the monitor is green. If not, and the Power Saving light is lit, press the [Shift] key to reactivate monitor.
	Monitor has failed.	If available, try another monitor. If the new monitor operates correctly, replace the old monitor following the Customer Replacement Unit process described in the Warranty and Information booklet.
	Video controller has failed.	Replace the main logic board.
No screen display.	Power indicator is defective.	Follow the Customer Replacement Unit process to replace the monitor.
	Configuration error.	Run the BIOS Setup utility to configure the computer for correct video operation.
	Monitor brightness and contrast controls are incorrectly set.	Adjust the monitor brightness and contrast controls.
No monitor display while loading Windows video drivers.	The monitor-off timer shut off the monitor.	Press [Shift] to reactivate monitor.
	Monitor type incorrectly set.	Set the correct monitor type using the appropriate utility.
	Wrong Windows driver loaded.	Load the correct video driver.

*continued*

## Troubleshooting

<b>Problem</b>	<b>Possible Cause</b>	<b>Action</b>
Distorted, rolling, or flickering screen display, or wrong/uneven color.	Monitor incorrectly adjusted.	Adjust accordingly.
	Monitor signal cable incorrectly installed.	Straighten any bent connector pins and then reconnect.
	Wrong refresh rate set in Windows 95 or Windows NT Workstation.	If using Windows 95, reboot the computer in safe mode and then correct the refresh rate according to the documentation supplied with the computer. If using Windows NT Workstation, select VGA mode to boot at a default rate and then correct the refresh rate.
Color monitor displaying monochrome.	Computer was turned on before the monitor was turned on.	Turn off the computer, turn on the monitor, then turn the computer back on.
Monitor fails to switch to high-resolution mode.	Appropriate high-resolution video drivers are not installed or incorrectly installed.	Correctly install all appropriate high-resolution video drivers. Refer to the documentation supplied with the monitor.
Monitor display not centered while loading Windows video drivers.	Monitor type incorrectly set.	Set the correct monitor type.
Monitor display disappears.	Screen display sized incorrectly.	Correctly size screen display.

## Error Messages

This section lists computer messages you might see or hear when you turn on power. The computer messages are grouped as follows:

- POST and boot computer messages
- POST execution messages
- Beep codes

## POST Messages

The POST displays messages to alert you to errors in hardware, software, and firmware or to provide operating information about the computer.

Each time the POST displays a message on the screen, the computer's speaker beeps twice. If an error occurs before the monitor is initialized, specific beep codes sound to alert you to a problem. The following table lists a general grouping of computer messages. In addition, each message is accompanied by text describing the message and in most cases, a recommended solution to the problem.



**NOTE:** Italics indicate variable parts of a message such as memory addresses, hexadecimal values, and so on. These messages can differ at each occurrence.

## POST and Boot Messages

Message	Description/Solution
nnnn Cache SRAM Passed	Where <i>nnnn</i> is the amount of computer cache (in kilobytes) that tested successfully.
Diskette drive A error	Run the BIOS Setup utility. Check all connections. If the problem persists, replace the diskette drive.
Diskette drive B error	
Entering SETUP	BIOS Setup utility runs.
Extended RAM Failed at offset: <i>nnnn</i>	Extended memory failed or configured incorrectly.  Make sure DIMMs are installed correctly (Refer to <i>System Reference</i> manual). If the problem persists, replace any faulty DIMMs.  Run the BIOS Setup utility and restore all settings to original values.
nnnn Extended RAM Passed	Where <i>nnnn</i> is the amount of extended memory (in kilobytes) that tested successfully.
Failing Bits: <i>nnnn</i>	<i>nnnn</i> is a map of the bits at the RAM address which failed the memory test.  Run the BIOS Setup utility and restore all to original values.  If the problem persists, replace any faulty DIMMs.
Fixed Disk 0 Failure	Run the BIOS Setup utility. Check all connections. If the problem persists, replace the hard disk drive.
Fixed Disk 1 Failure	
Fixed Disk Controller Failure	Fixed disk controller failure. Check fixed disk connections. Run Setup to be sure the fixed-disk type is correctly identified.
Incorrect Drive A type - run SETUP	Diskette drive A and/or B not correctly identified in the BIOS Setup utility.
Incorrect Drive B type - run SETUP	Run the BIOS Setup utility and properly identify diskette drive A and/or B.

*continued*

Message	Description/Solution
Invalid NVRAM media type	NVRAM access failed. Run the BIOS Setup utility and restore all settings to original values. If the problem persists, replace the main logic board.
Keyboard controller error	Check the keyboard connection. If the connection is secure, the keyboard or keyboard controller might have failed. If the problem persists, replace the main logic board or keyboard.
Keyboard error	
keyboard error nn	
Keyboard locked - Unlock key switch	
Monitor type does not match CMOS - Run SETUP	Run the BIOS Setup utility and set the correct monitor type.
Operating system not found	The operating system cannot be found on drive A or drive C. Run the BIOS Setup utility and correctly identify drive A or drive C. Correctly install the operating system. Refer to the supplied operating system documentation.
Parity Check 1 nnnn	Parity error found in system bus. BIOS will attempt to locate the address and display it on the screen.
Parity Check 2 nnnn	
Press <F1> to resume, <F2> to Setup	This message appears after any recoverable error message. Press [F1] to reboot or [F2] to enter the BIOS Setup utility to make any necessary changes.
Press <F2> to enter Setup	Optional message displayed during POST. Can be turned off in Setup.
Previous boot incomplete - default configuration used	Previous POST did not complete successfully. POST loads default values and offers to run Setup.
Real time clock error	Battery failed BIOS test. Replace battery and then run the BIOS Setup utility to restore previous configuration information.

*continued*

## Troubleshooting

Message	Description/Solution
Shadow RAM Failed at offset: <i>nnnn</i>	Shadow RAM failed. Run the BIOS Setup utility and disable failed shadow memory region.
<i>nnnn</i> Shadow RAM passed	Where <i>nnnn</i> is the amount of shadow RAM (in kilobytes) that tested successfully.
System Battery is dead - Replace and run SETUP	Replace the battery and then run the BIOS Setup utility to restore previous configuration information.
System BIOS shadowed	This indicates that the computer's BIOS was successfully copied to shadow RAM.
System cache error - Cache disabled	RAM cache failed. Run the BIOS Setup utility and restore all settings to original values. If the problem persists, replace faulty processor.
System CMOS checksum bad - run SETUP	Correct the address conflict using the BIOS Setup utility. If the problem persists, replace the main logic board.
System RAM failed at offset: <i>nnnn</i>	System RAM failed. Run the BIOS Setup utility and restore all settings to original values. If the problem persists, replace any faulty DIMMs.
<i>nnnn</i> System RAM passed	Where <i>nnnn</i> is the amount of system RAM (in kilobytes) that tested successfully.
System timer error	The computer's timer test failed. Run the BIOS Setup utility and restore all settings to original values. If the problem persists, replace the main logic board.
UMB upper limit segment address: <i>nnnn</i>	Displays the address of the upper limit of UMB. This indicates the released segments of the BIOS that can be reclaimed by a virtual memory manager.
Video BIOS shadowed	This indicates that the computer's video BIOS was successfully copied to shadow RAM.

## POST Execution Messages

During bootup, the BIOS carries out a POST routine which checks the system functions. While only a few execution messages display at the bottom of the screen, the following tests are performed. If BIOS detects an error, the associated code will be sent to port 80h. If the system hangs before the BIOS can process the error, the value displayed at port 80h is the last test performed.

Code	Description
02h	Verify Real Mode
04h	Get CPU type
06h	Initialize system hardware
08h	Initialize chipset registers to their initial POST values.
09h	Set in-POST flag
0Ah	Initialize CPU registers
0Bh	Enable CPU cache
0Ch	Initialize caches to initial POST values
0Eh	Initialize I/O
0Fh	Initialize local bus IDE
10h	Initialize Power Management
11h	Load alternate registers with initial POST value
12h	Restore CPU control word during warm boot
13h	Reset PCI bus master
14h	Initialize keyboard controller
16h	ROM BIOS checksum
17h	Initialize external cache before RAM autosize
18h	8254 timer initialization
1Ah	8237 DMA controller initialization
1Ch	Reset Programmable Interrupt Controller
20h	Test DRAM refresh
22h	Test 8742 Keyboard Controller
24h	Set segment-register addressability to 4 GB

*continued*

## Troubleshooting

<b>Code</b>	<b>Description</b>
28h	Autosize DRAM
2Ah	Clear 512K base RAM
2Ch	RAM failure on address line xxxx*
2Eh	RAM failure on data bits xxxx* of low byte of memory bus
2Fh	Initialize external cache before shadowing
30h	RAM failure on data bits xxxx* of high byte of memory bus
32h	Test CPU bus-clock frequency
34h	Test CMOS RAM
35h	Initialize alternate chipset registers
36h	Warm start shut down
37h	Re-initialize the chipset (MB only)
38h`	Shadow system BIOS ROM
39h	Reinitialize the cache (MB only)
3Ah	Autosize cache
3Ch	Configure advanced chipset registers
3Dh	Load alternate registers with CMOS value
42h	Initialize interrupt vectors
44h	Initialize BIOS interrupt
46h	Check ROM copyright notice
47h	Initialize manager for PCI Option ROMs
48h	Check video configuration against CMOS
49h	Initialize PCI bus and devices
4Ah	Initialize all video adapters in system
4Bh	Display QuietBoot screen
4Ch	Shadow video BIOS ROM
4Eh	Display copyright notice.
50h	Display CPU type and speed
51h	Initialize EISA board
52h	Test keyboard

*continued*



<b>Code</b>	<b>Description</b>
54h	Initialize keystroke clicker if enabled in Setup.
56h	Send a command to keyboard controller to enable the keyboard.
58h	Test for unexpected interrupts
5Ah	Display prompt "Press F2 to enter SETUP"
5Bh	Disable CPU cache
5Ch	Test RAM between 512K and 640K
60h	Test extended memory
62h	Test extended memory address lines
64h	Jump to UserPatch1
66h	Configure advanced cache registers
68h	Enable external cache and CPU caches
6Ah	Display external cache size
6Ch	Display shadow message
6Eh	Display non-disposable segments
70h	Display error messages
72h	Check for configuration errors
74h	Test Real Time Clock
76h	Check for keyboard errors
7Ch	Set up hardware interrupt vectors
7Eh	Test coprocessor if present
80h	Disable onboard I/O ports
82h	Detect and install external RS232 ports
84h	Detect and install external parallel ports
85h	Display any ESCD read errors and initialize PnP ISA devices.
86	Reinitialize onboard I/O ports
88h	Initialize BIOS Data Area
8Ah	Initialize Extended BIOS Data Area
8Ch	Initialize floppy controller
8Fh	Count the number of ATA drives on the system

*continued*

## Troubleshooting

<b>Code</b>	<b>Description</b>
90h	Initialize hard-disk controller
91h	Initialize local-bus hard-disk controller
92h	Jump to UserPatch2
93h	Build the MPTABLE for multi-processor cards
94h	Disable A20 address line.
95h	Initialize bootable CD-ROM
96h	Clear huge ES segment register
97h	Create pointer to MP table in Extended BDA
98h	Search for option ROMs - One long, two short beeps on checksum failure
9Ah	Shadow option ROMs
9Ch	Set up Power Management
9Eh	Enable hardware interrupts
9Fh	Check the total number of Fast Disks (ATA and SCSI)
A0h	Set time of day
A2h	Check Numlock
A4h	Initialize typematic rate
A8h	Erase "Press F2 for Setup" prompt
AAh	Scan for F2 keystroke
ACh	Enter SETUP if F2 was pressed
AEh	Clear in-POST flag
B0h	Check for errors
B2h	POST done - prepare to boot operating system
B4h	One short beep before boot
B5h	Clear QuietBoot screen
B6h	Check password (optional)
B8h	Clear global descriptor table
BAh	Initialize Desktop Management Interface (DMI)
BCh	Clear parity checkers
BDh	If MultiBoot is installed, display Boot First menu

*continued*

<b>Code</b>	<b>Description</b>
BEh	Clear screen before booting (optional)
BFh	Check virus and backup reminders
C0h	Try to boot with INT 19
D0h	Interrupt handler error
D2h	Unknown handler error
D4h	Pending interrupt error
D6h	Initialize option ROM error
D8h	Shutdown error
DAh	Extended Block Move
DCh	Shutdown 10 error

\* If the BIOS detects error 2C, 2E, or 30 (base 512K RAM error), it displays an additional word-bitmap (xxxx) indicating the address line or bits that failed. For example, "2C 0002" means address line 1 (bit one set) has failed. "2E 1020" means data bits 12 and 5 (bits 12 and 5 set) have failed in the lower 16 bits. Note that error 30 cannot occur on 386SX systems because they have a 16 rather than 32-bit bus. The BIOS also sends the bitmap to the port-80 LED display. It first displays the check point code, followed by a delay, the high order byte, another delay, and then the low order byte of error. It repeats this sequence continuously.

## Troubleshooting

The following are for boot block in Flash ROM:

<b>Code</b>	<b>Description</b>
E2h	Initialize the chipset
E3h	Initialize refresh counter
E4h	Check for Forced Flash
E5h	Check HW status of ROM
E6h	BIOS ROM is OK
E7h	Do a complete RAM test
E8h	Do OEM initialization
E9h	Initialize interrupt controller
Eah	Read in the bootstrap code
Ebh	Initialize all vectors
Ech	Boot the Flash program
Edh	Initialize the boot device
Eeh	Boot code was read OK

## Beep Codes

When POST finds an error and cannot display a message, the computer's speaker emits a series of beeps to indicate the error and places a value in I/O port 80h. During POST, if the video configuration fails or if an external ROM module fails a checksum test, then the computer beeps three times (one long beep, and two short beeps).

The following table lists other fatal errors and their associated beep codes. Each code represents the number of short beeps that are grouped together. Fatal errors (errors that lock up the computer) are generally the result of a failed main logic board or some other add-on component (DIMM, BIOS, computer battery, etc.).

Beep Code	Error
1	One short beep before boot
1-2	Search for option ROMs
1-2-2-3	BIOS ROM checksum
1-3-1-1	Test DRAM refresh
1-3-1-3	Test keyboard controller
1-3-4-1	Test 512K base address lines
1-3-4-3	Test 512K base memory
1-4-1-1	Test memory bus
2-1-2-3	Check ROM copyright notice
2-2-3-1	Test for unexpected interrupts

# Parts Replacement **5**

---

## Introduction

The following sections list the Illustrated Parts Breakdown (IPB) part numbers and related replacement procedures.

## DIGITAL PC 3010 IPB List

Figure Legend	Spare Part Number	Exchangeable Part Number	Description
1	90-08268-00		Compound, thermal joint
	21-45670-01		CPU assembly, AMD-K6 with MMX, 166 MHz
	21-45670-02		CPU assembly, AMD-K6 with MMX, 200 MHz
	21-47440-01		CPU assembly, Intel Pentium with MMX, 166 MHz
	21-47440-03		CPU assembly, Intel Pentium with MMX, 200 MHz
	12-41706-06		Heat sink and clips (Intel)
	12-45629-01		Heat sink and clips (AMD)
2	30-48973-01		Main logic board DIGITAL PC 3010
3	74-50733-01		Bracket, base side, low profile
4	54-25084-AA	20-47177-D2	DIMMs, SDRAM, 16 MB, 100 MHz
	54-25084-CA	20-47474-D2	DIMMs, SDRAM, 32 MB, 100 MHz
5	30-48972-01		Riser card
6	70-32677-01		Enclosure, low profile
7	74-50747-01		Option filler plate
8	30-48269-01	36-17905-16	Power supply (low profile 100 W)
9	74-50734-01		Internal drive bracket
10	PCXRA-AJ		HDD,UDMA, IDE, 1.2 GB, 3.5-inch
	PCXRA-AV		HDD,UDMA, IDE, 2.0 GB, 3.5-inch
	PCXRA-AR		HDD,UDMA, IDE, 2.1 GB, 3.5-inch
11	70-32675-01		Top cover, with bezel and filler panel
	70-32893-01		Bezel, with filler panels
12	70-50742-01		Bezel blank, 5.25" Drive
13	70-32692-01		Assembly, control panel
14	12-45246-03		Fan, 80mm brushless DC
15	PCXRJ-AD		1.44 MB floppy disk drive frost white flat bezel
16	74-50762-01		Bracket, 3.5" FDD
17	12-41474-05		Battery, 3 VDC lithium, CR2032

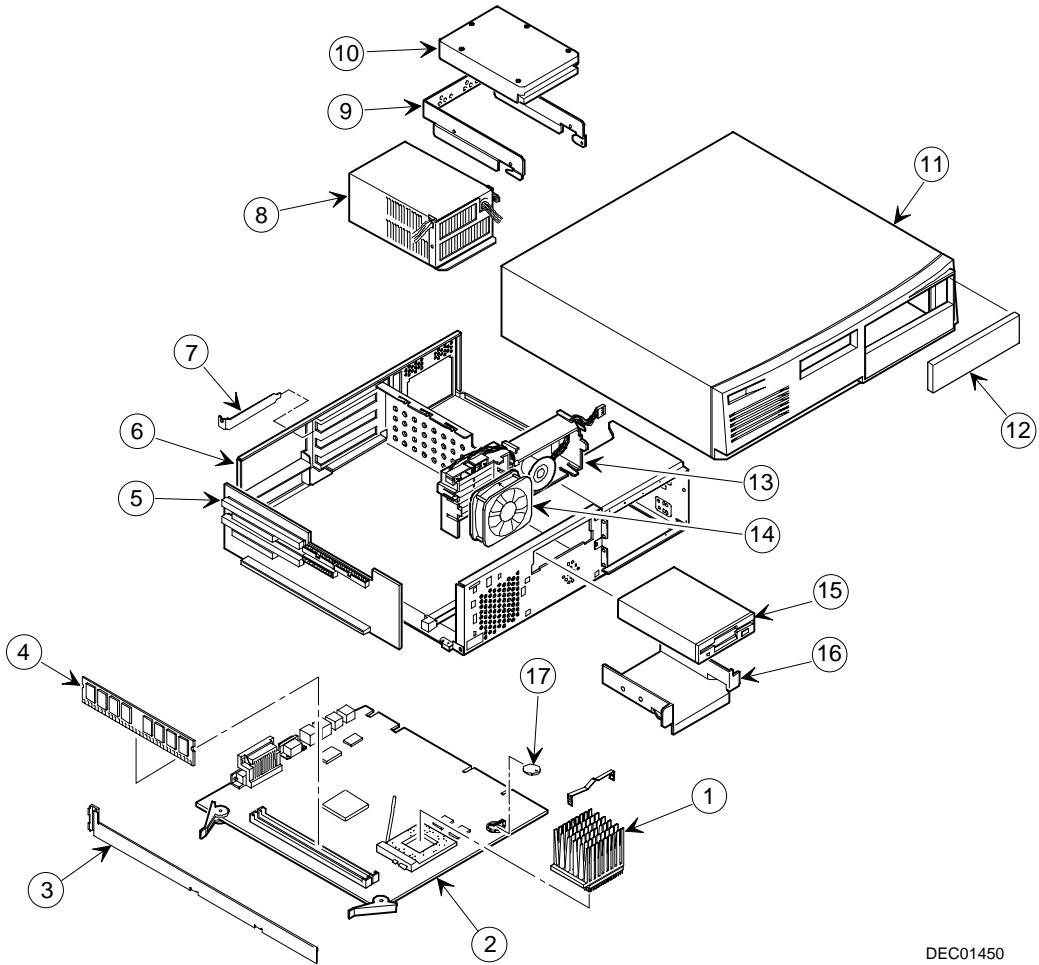

DIGITAL PC 3010

DEC01450

Figure 5-1. DIGITAL PC 3010



## Enclosure

Spare Part Number	Exchangeable Part Number	Description
12-44147-01		Screw, captive 6-32
12-47296-01		Key lock
74-48510-01		Expansion bracket, 5.25" to 3.5"
74-49365-01		Holder, drive rail
74-49836-01		Bumper for MLB
74-50752-01		Bracket EMI shield, 5.25"
74-50798-01		Air duct, low profile
74-50804-01		Rubber feet
74-50911-01		Bracket, I/O expansion
74-50912-01		3.5" FDD shield, blank
74-50913-01		Bezel, 3.5" FDD blank
74-50958-01		Bracket, hasp
90-08020-01		Screw, machine 6-32 pan .187 XRCS (HDD)
90-09538-02		Bumper, rubber adhesive back, 16mm diameter
90-11334-01		Screw, machine 6-32 pan .256 XRCS CSZ
90-40217-01		Screw, machine M3 pan 5mm XRCS CSZ (FDD and CD-ROM)

## Cables

Spare Part Number	Exchangeable Part Number	Description
17-03460-12		Cable assembly, flat, 34 position, 430 mm
17-03460-13		Floppy cable assembly, flat, 34 position, 400 mm
17-03461-12		IDE cable assembly, flat, 40 position, 200 mm, one connector
17-03461-13		Cable assembly, flat, 40 position, 265 mm
17-03461-14		Cable assembly, flat, 40 position, 295 mm
17-04372-01		Cable, control panel
70-31909-03		Cable assembly, microswitch, 14.2 inch
70-31909-04		Cable assembly, microswitch, 7.0 inch

## Nameplates

Spare Part Number	Exchangeable Part Number	Description
74-48816-01		DIGITAL medallion, front panel
74-51175-09		Nameplate, DIGITAL PC
74-51176-58		Speed button, 3000

## Options

<b>Spare Part Number</b>	<b>Exchangeable Part Number</b>	<b>Description</b>
DE500-BA		10/100Base Ethernet adapter (PCI)
DE305-AA		10 mbs ISA network adapter
DE450-CA		10 mbs PCI network adapter
PCCAM-EB		16MB SDRAM (DIMM), 100MHz
PCCAM-EC		32MB SDRAM (DIMM), 100MHz
PCCAM-ED		64MB SDRAM (DIMM), 100MHz
PCXBJ-DG		Labtech speakers
PCXBV-FZ		17" SVGA monitor
PCXCV-CW		14" SVGA monitor
PCXCV-DW		15" SVGA monitor
PCXJD-AB		Sound Blaster PnP Sound Card
PCXJF-AC		Headphone set
PCXLA-NA		Keyboard, frost white, North America
PCXLA-AA		Keyboard, frost white, Europe
PCXLN-AB		Mouse, 2-button, frost white, single pack
PCXLN-AD		Mouse, 3-button, frost white, single pack
PCXRN-AM	PCXRN-AN	24X IDE CD-ROM drive

## Service Procedures

The following sections provide detailed service instructions for DIGITAL PC 3010 computers.



**CAUTION:** Static electricity collects on non-conductors such as paper, cloth, or plastic. A static discharge can be damaging even though you often cannot see or feel it. To prevent damage to circuit boards and/or components:

- Before touching any circuit board or component, touch the metal frame of the computer to discharge any static electricity.
- Keep circuit boards and components away from non-conductors.

## Recommended Tools

Have the following tools available:

- Multimeter (4½-inch digit)
- Phillips screwdriver
- Antistatic wrist strap (recommended, but not required)

## Other Materials Needed

Cleaning agent should be an all purpose cleaner that is used in-house.

## Special Tools Required

None.

## **Remedial Diagnostic Test Software**

Supplier information:

AMI Diagnostics  
6145-F Northbelt Parkway  
Norcross, GA 30071, U.S.A.  
Voice: 1-770-246-8600  
FAX: 1-770-246-8791  
Support: 1-770-246-8645  
Internet: <http://www.megatrends.com>

## **Virus Software Information**

F-PROT, Virus Detection and Cleanup Software, latest version.

Supplier information:

North America, South America, Australia and New Zealand  
Command software Systems Inc.  
Tel: +1-407-575 3200  
FAX: 1-407-575-3026

## **BIOS Version Information**

Refer to the DIGITAL Web page for the latest information on BIOS upgrades:

**[WWW.WINDOWS.DIGITAL.COM](http://WWW.WINDOWS.DIGITAL.COM)**

## **Disconnecting External Devices and Power**

1. Turn off power to all external devices connected to computer.
2. Turn the computer off.
3. Disconnect power from the wall outlet.
4. Disconnect the power cord and monitor cord.

## Removing the Outside Cover

To remove your computer's outside cover:

1. Turn off power to all external devices connected to your computer.
2. Turn your computer off.
3. Unplug your computer and monitor power cord from the wall outlet.
4. For computers without a chassis lock, go to step 4a. For computers with a chassis lock, go to step 4b.
  - a. Release the outside cover by loosening the rear-panel thumbscrew(s).
  - b. Unlock the outside cover by inserting the key and turning it counter clockwise.
5. Slide the outside cover forward for the low profile and backwards for the short tower.
6. Carefully lift the outside cover away from the chassis.



**CAUTION:** Static electricity collects on non-conductors such as paper, cloth, or plastic. A static discharge can be damaging even though you often cannot see or feel it. To prevent damage to circuit boards and/or components:

- Before touching any circuit board or component, touch the metal frame of your computer to discharge any static electricity.
- Keep circuit boards and components away from non-conductors.

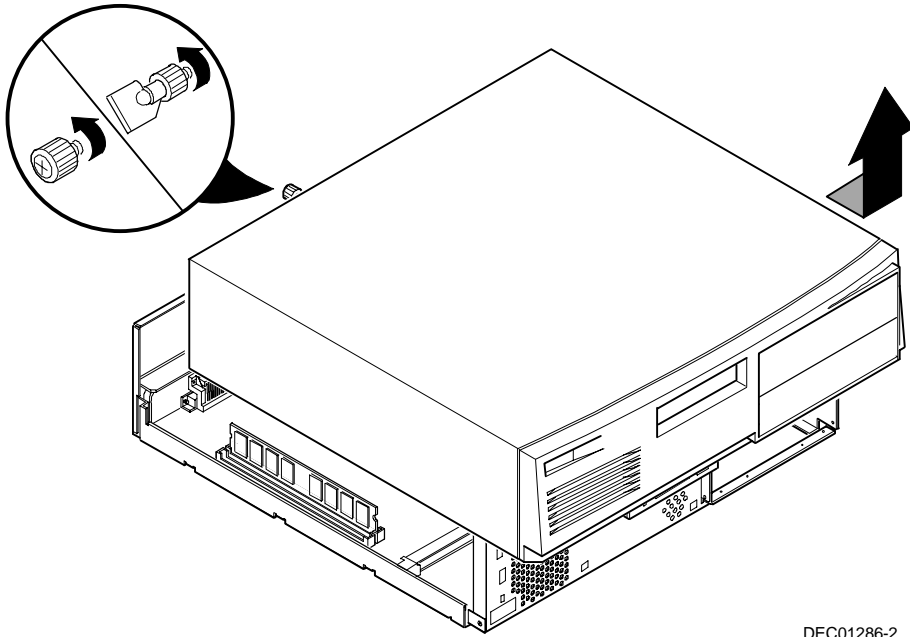

DEC01286-2

**Figure 5-3. Removing the Outside Cover**



## Computer Components

The following sections identify the DIGITAL PC 3010 computer components including: main logic components, main logic board connectors, backplane components, expansion slots, main logic board jumper locations, and memory configurations.

### Main Logic Board Components and Connectors

Figure Legend	Component
A	Computer flash and video BIOS
B	Computer battery
C	Fan connector (User option)
D	Onboard 256 KB pipeline burst cache
E	Pentium processor (CPU) socket
F	Two 168-pin, DIMM, 64-bit SDRAM sockets
G	SiS 5597 Pentium PCI/ISA controller
H	Super I/O controller

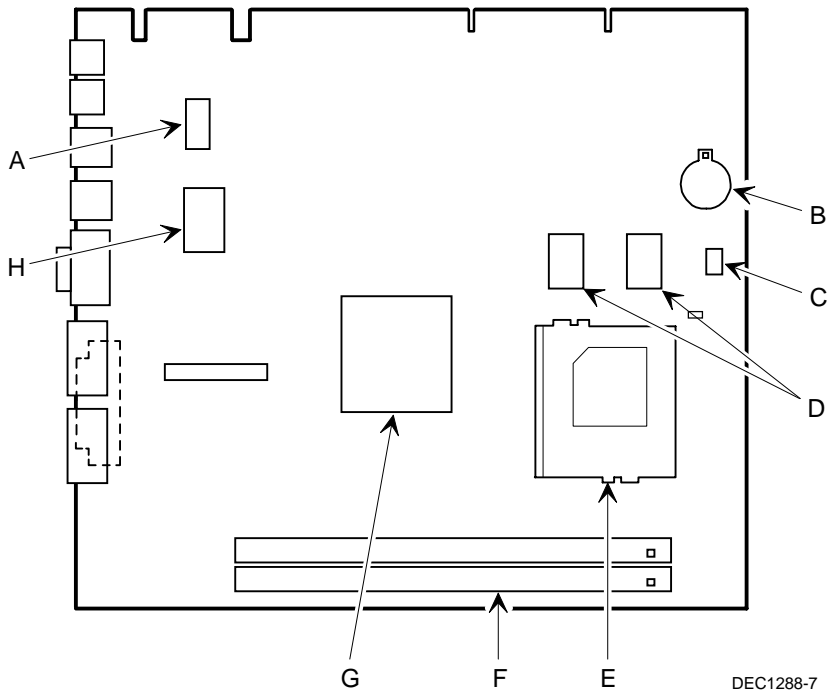

DIGITAL PC 3010

Figure 5-4. Main Logic Board Components

## Main Logic Board Connectors (Rear Panel)

Figure Legend	Connector
A	Keyboard port
B	Mouse port
C	Two USB ports
D	Video (VGA) port
E	Serial ports
F	Parallel port

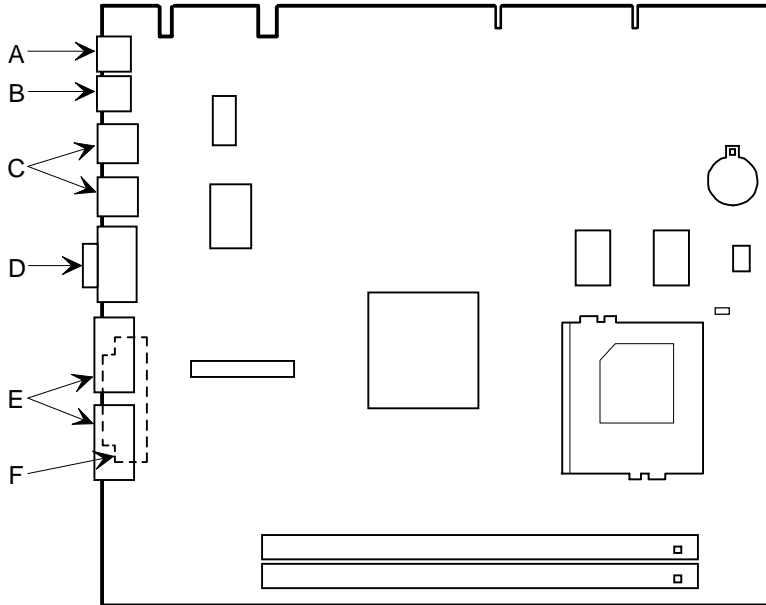

DEC01288-2

Figure 5-5. Main Logic Board Components (Rear Panel)

## Backplane Components and Connectors

Figure Legend	Connector
A	PCI expansion board connectors
B	ISA expansion board connectors
C	Primary IDE drive connector
D	Secondary IDE drive connector (recommended for an installed CD-ROM drive)
E	Diskette drive connector
F	SCSI activity connector <sup>(1)</sup>
G	Control panel connector
H	Fan connector (User option)
I	Main logic board connectors
J	Power connector

(1) The SCSI activity connector is for use only when installing a SCSI drive. This allows SCSI activity to be display on the front panel.

Parts Replacement

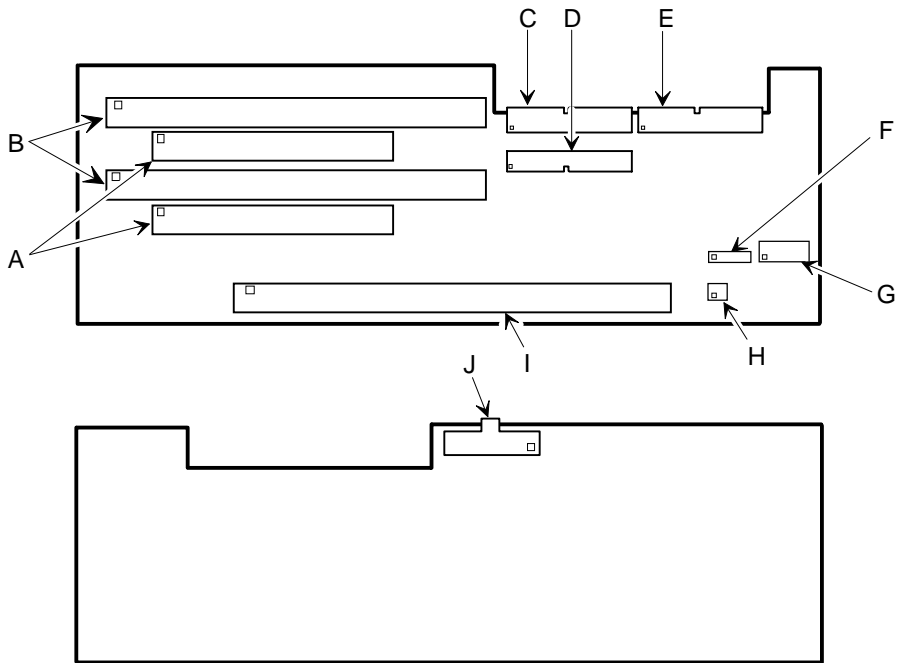

DEC01295-2

**Figure 5-7. Backplane Components and Connectors**

## Expansion Slot Locations

Expansion Slot Designation	Description
ISA2	Supports half-length industry-standard 16-bit ISA expansion boards Uses the top expansion slot at the rear panel
PCI1	Supports full-length 32-bit PCI local bus expansion boards Uses the middle expansion slot at the rear panel Designated as a shared slot with ISA slot ISA1 <sup>(1)</sup>
ISA1	Supports full-length industry-standard 16-bit ISA expansion boards Uses the middle expansion slot at the rear panel Designated as a shared slot with PCI slot PCI2 <sup>(1)</sup>
PCI2	Supports half-length 32-bit PCI local bus expansion boards Uses the bottom expansion slot at the rear panel

<sup>(1)</sup> Only one expansion board can reside in slot PCI2 and ISA1 at any one time. These slots have to share the middle expansion slot opening at the rear panel, thus, a maximum of three expansion boards can be supported at any one time.

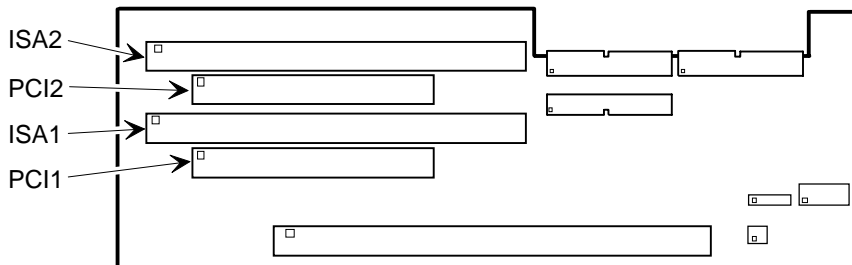

DEC01295-3

**Figure 5-10. Expansion Board Slots**

## Main Logic Board Jumper Settings

The jumper settings located on the main logic board can be set to control many features in your computer. Use the following table and figure to locate the jumper settings on the main logic board and then modify the settings for desired results.

Feature	Function	Setting	Description
Internal VGA	Disable	W1, ON	Allows you to disable the onboard video controller. Must be set with W22 to select onboard video controller or external, add-on video card.
	Enable	W1, OFF <sup>(1)</sup>	
CPU bus speed ratio	2.0	W2, ON	Sets processor clock speed x 2
		W3, OFF	
		W4, OFF	
	2.5	W2, ON	Sets processor clock speed x 2.5 Default for 166 MHz processors
W3, ON			
W4, OFF			
3.0	W2, OFF	Sets processor clock speed x 3 Default for 200 MHz processors	
	W3, ON		
	W4, OFF		
3.5	W2, OFF	Sets processor clock speed x 3.5 Must be set with jumpers W5, W6, and W7 to match the CPU clock speed. For example, 66 MHz x 3 = 200 MHz processor.	
	W3, OFF		
	W4, OFF		
Clock frequency	50 MHz	W5, pins 2 and 3, ON	Sets the clock frequency of the CPU. Must be set with jumpers W2, W3, and W4 to match the CPU bus speed ratio. For example, 66 MHz x 3 = 200 MHz processor.
		W6, pins 2 and 3, ON	
		W7, pins 2 and 3, ON	
60 MHz	60 MHz	W5, pins 2 and 3, ON	
		W6, pins 2 and 3, ON	
		W7, pins 1 and 2, ON	
66 MHz	66 MHz	W5, pins 2 and 3, ON <sup>(1)</sup>	
		W6, pins 1 and 2, ON <sup>(1)</sup>	
		W7, pins 2 and 3, ON <sup>(1)</sup>	
Burst mode	Linear burst	W10, ON	Determines the type of burst mode. ON = Linear burst OFF = Interleave (Intel, AMD)
		W10, OFF <sup>(1)</sup>	
		Interleave	

(1) Factory default setting

OFF = jumper not installed; ON = jumper installed

*continued*

Feature	Function	Setting	Description
CMOS /RTC battery	Normal	W11, pins 1 and 2, ON <sup>(1)</sup>	Clears CMOS of all BIOS setup information. Use the Clear setting when your computer will not boot, and BIOS setup cannot be accessed due to configuration data corruption. This jumper must be set back to Normal before rebooting your computer.
	Clear CMOS	W11, pins 2 and 3, ON	
CPU voltage	Intel Pentium	W16, OFF	Sets the CPU voltage to 3.5 V dc.
		W17, OFF	
		W18, OFF	
		W23, ON	
	W24, OFF		
Intel Pentium w/MMX	W16, ON <sup>(1)</sup>	Sets the CPU voltage to 2.8 V dc.	
	W17, OFF <sup>(1)</sup>		
	W18, OFF <sup>(1)</sup>		
	W23, OFF <sup>(1)</sup>		
W24, OFF <sup>(1)</sup>			
AMD-K6 166/200 MHz	W16, OFF	Sets the CPU voltage to 2.9 V dc.	
	W17, ON		
	W18, OFF		
	W23, OFF		
W24, OFF			
Reserved for future use	W16, OFF	Sets the CPU voltage to 3.2 V dc.	
	W17, OFF		
	W18, ON		
	W23, OFF		
W24, OFF			
Reserved for future use	W16, OFF	Sets the CPU voltage to 2.1 V dc.	
	W17, OFF		
	W18, OFF		
	W23, OFF		
W24, ON			
Internal VGA	Disabled	W22, pins 1 and 2, ON	Allows you to disable the internal video controller. Must be set with W1 to select onboard video controller or external video expansion board.
	Enabled	W22, pins 2 and 3, ON <sup>(1)</sup>	

(1) Factory default setting

OFF = jumper not installed; ON = jumper installed



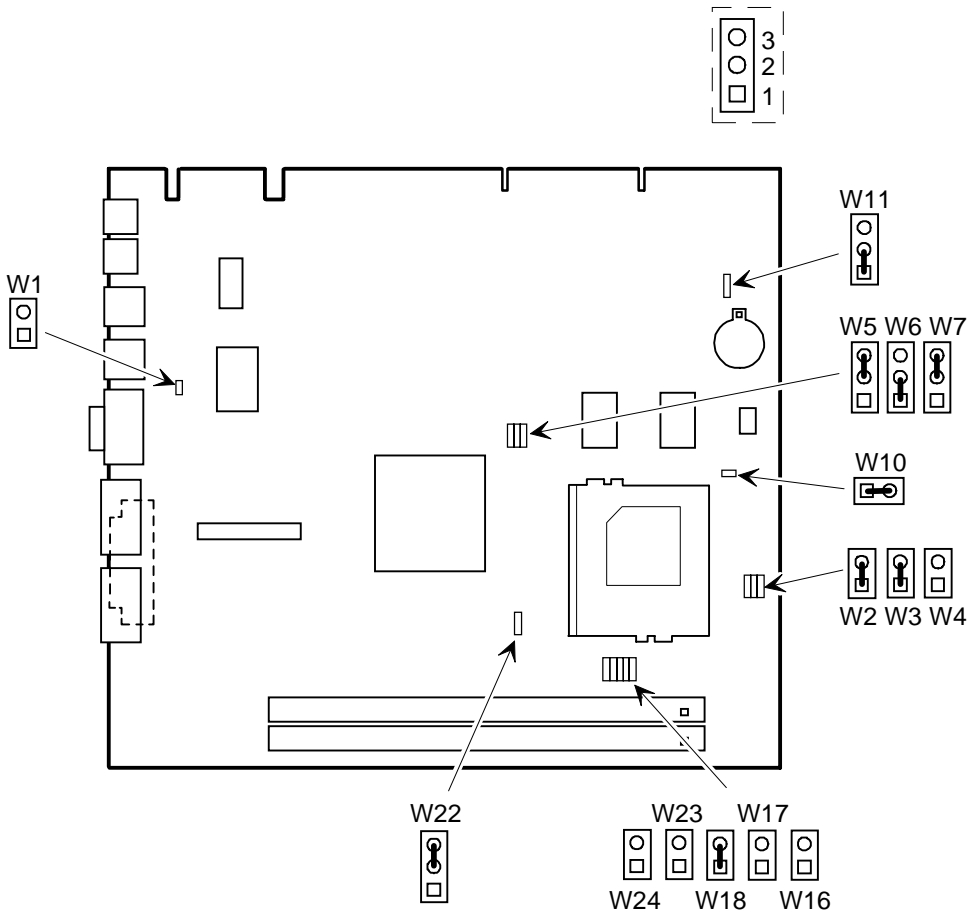

DEC1288-6

Figure 5-12. Main Logic Board Switch Settings

## Installing Additional Computer Memory

Your computer supports 168-pin DIMM memory modules utilizing Synchronous Dynamic Random Access Memory (SDRAM) technology. SDRAMs operate at speeds of 66 MHz (or greater) over a local memory bus, which is much faster than SIMMs using ECC or EDO memory.

Your computer came with 16 MB of computer memory. Adding more memory enables your computer to run larger, more complicated software and run it more quickly. DIMMs are available in 16 MB, 32 MB, 64 MB, and 128 MB memory module sizes to expand your computer memory up to 256 MB. Contact your local DIGITAL sales representative for ordering information.

Computer memory is installed using the two DIMM sockets located on the main logic board as shown in Figure 4-1. Sockets J2 and J3 can accept either single or dual bank DIMMs.

When adding memory make sure you reference the memory configuration table and follow these memory expansion guidelines:

- Install 168-pin DIMMs using 66 MHz (or faster), 64-bit SDRAMs.



**NOTE:** Install DIMMs supplied by Digital Equipment Corporation and qualified vendors. DIGITAL does not support computer performance, product warranty, or service calls resulting from installation of non-qualified DIMMs.

- Single bank DIMMs are available in 16 MB and 64 MB memory modules. Single bank DIMMs have components to provide one 64-bit wide memory access.
- Dual bank DIMMs are available in 32 MB and 128 MB memory modules. Dual bank DIMMs have two sets of components, each providing 64 bits (ECC DIMMs are 72 bits wide).
- Memory sockets J2 and J3 support both single and dual bank DIMMs.
- If populating only one DIMM socket, DIMM0 must be used. If DIMM1 socket is populated and not DIMM0, the system will not function properly.

Parts Replacement

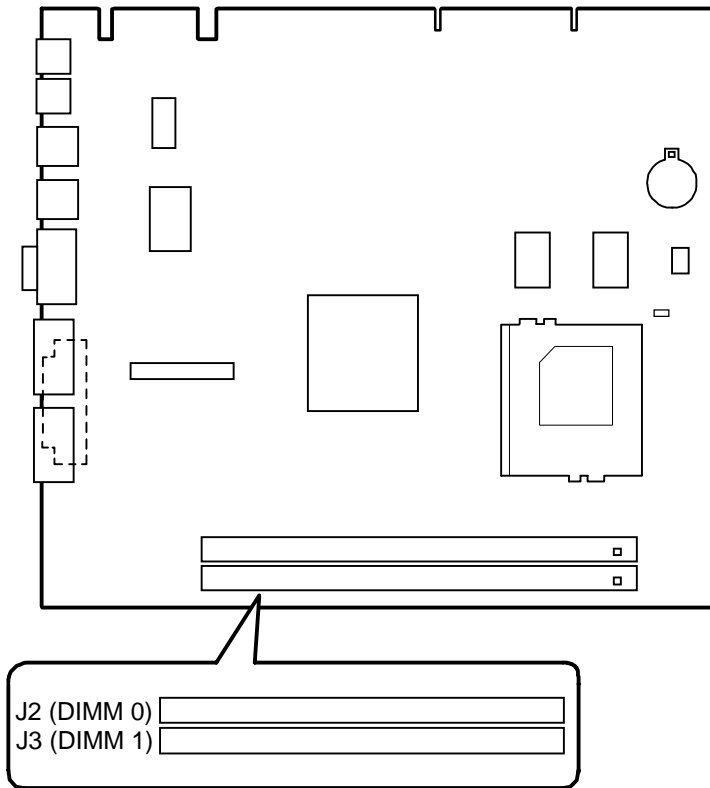

DEC01288-3

**Figure 5-13. DIMM Socket Locations**

## Memory Configurations

<b>DIMM 0 Socket J2</b>	<b>DIMM 1 Socket J3</b>	<b>Total</b>
16 MB		16 MB
16 MB	16 MB	32 MB
32 MB		32 MB
32 MB	16 MB	48 MB
32 MB	32 MB	64 MB
64 MB		64 MB
64 MB	16 MB	80 MB
64 MB	32 MB	96 MB
64 MB	64 MB	128 MB
128 MB		128 MB
128 MB	16 MB	144 MB
128 MB	32 MB	160 MB
128 MB	64 MB	192 MB
128 MB	128 MB	256 MB

## Removing and Replacing Components

The following sections provide removal and replacement procedures for the following DIGITAL PC 3010 components:

- Main logic board
- DIMMs
- Video memory
- Battery
- Heat sink
- Processor
- VRM
- Backplane
- Expansion boards
- Power supply
- Control panel
- 3½-inch mass storage devices
- 5¼-inch mass storage devices

## Removing the Main Logic Board

To remove the main logic board:

1. Turn off your computer and monitor.
2. Disconnect all external devices, ac power, and monitor power.



**WARNING:** Make sure you disconnect the power cords from the computer and monitor or the power cords from the power outlets. When only the front panel switches are turned off, dc logic voltage is still present.

3. Remove the outside cover.
4. Swing the brace away from the chassis.
5. If necessary disconnect the CPU fan connector from the main logic board.
6. Pull out on the two latches attached to the main logic board.  
This separates the main logic board from the backplane.
7. Carefully remove the main logic board from the chassis.

## Parts Replacement

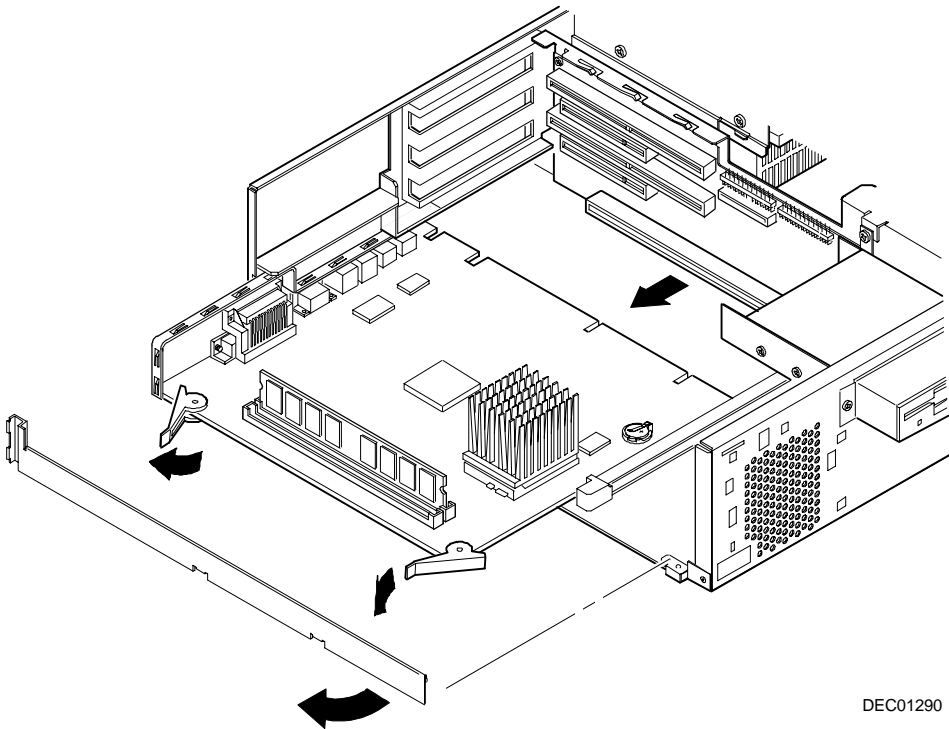

DEC01290

**Figure 5-14. Removing the Main Logic Board**

## Removing the DIMMs

1. Turn off the computer, monitor, and then disconnect power from the computer.
2. Remove the outside cover.
3. Press the DIMM retaining clips out.
4. Pull the DIMM out of the socket.



Parts Replacement

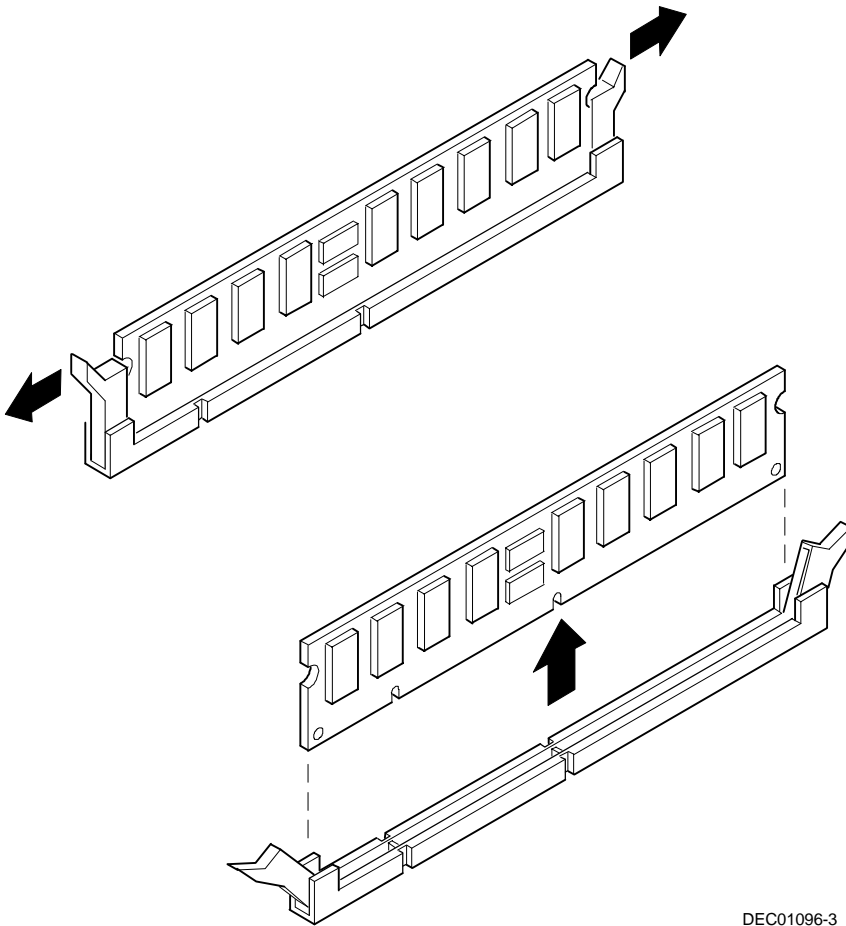

DEC01096-3

**Figure 5-16. Removing DIMMs**

## Removing the Lithium Battery

1. Record your computer's configuration settings using the BIOS Setup utility.
2. Turn off your computer and monitor.
3. Disconnect all external devices, ac power, and monitor power.
4. Remove the outside cover.
5. Lift the retaining clip slightly and push on the battery from the side to slide it out.



**WARNING:** There is a danger of battery explosion if a lithium battery is incorrectly replaced. To prevent damage to your computer, be sure the + side faces up when installing a new battery. Also, be sure you replace the battery with either a DIGITAL (P/N 12-41474-05), Toshiba (P/N CR2032), or equivalent 3 V dc lithium battery.

Depending on your locality, your computer's battery might be considered hazardous waste. Make sure you follow any state or local statute to properly dispose of the old battery.

6. Install the new battery.  
When installing the new battery, make sure the "+" side faces up.
7. Replace the outside cover.
8. Connect all external devices and restore power.
9. Run the BIOS Setup utility to reconfigure your computer using the recorded configuration settings from step 1.

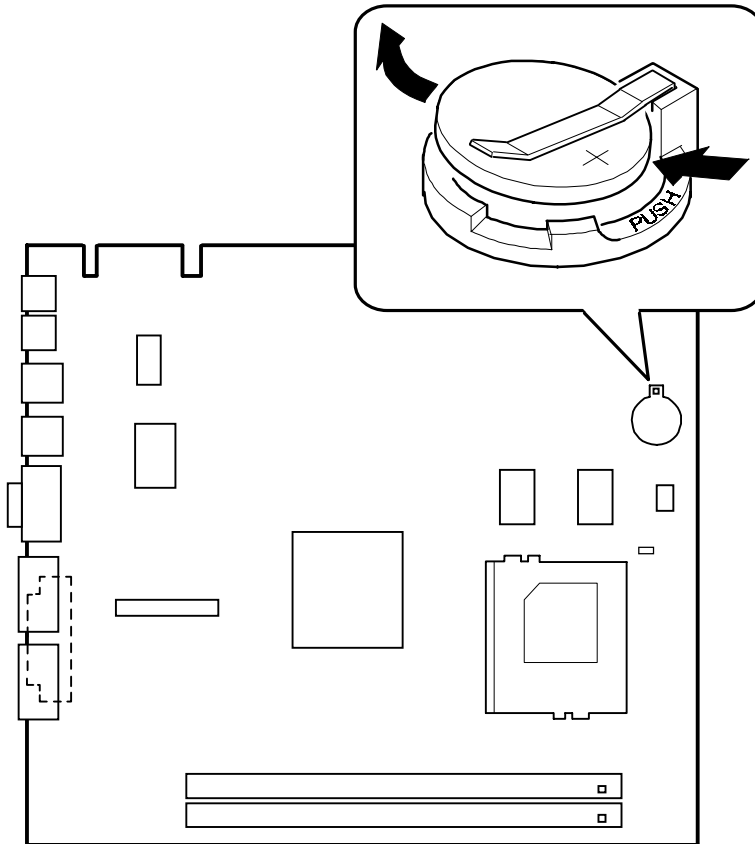

DEC01288-5

**Figure 5-18. Removing the Lithium Battery**

## Removing the Processor Heat Sink

1. Turn off the computer, monitor, and then disconnect power from the computer.
2. Remove the outside cover.
3. Using a small screwdriver, release the retaining clip on the heat sink.  
Use caution so as to avoid damaging the main logic board.
4. Separate the heat sink from the processor.  
To remove the heatsink, slide it off to the side. Do not try to lift it straight up.



**NOTE:** Between the heat sink and the processor is thermal compound to form a tight fit. When you replace the processor and heat sink, first insert the processor chip in the socket and move the lever down. Clean the bottom of the heat sink with a clean cloth dampened with isopropyl alcohol. Spread a smooth thin coat of thermal compound on the bottom of the heat sink. Place the heat sink on top of the processor and then secure the heat sink with the heat sink clip.

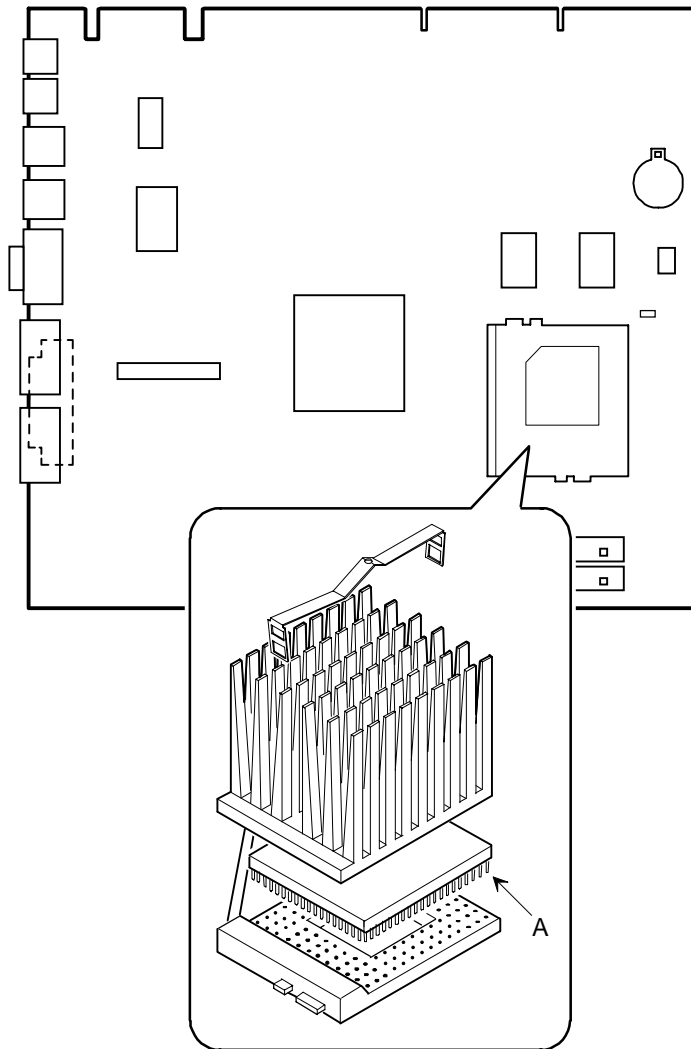

DEC01288-4

**Figure 5-19. Removing the Processor Heat Sink**

## Removing the Processor

1. Turn off the computer, monitor, and then disconnect power from the computer.
2. Remove the outside cover.
3. If necessary, remove the VRM.
4. Remove the heat sink.
5. Lift the lever out and then up.
6. Remove the processor. (A, Figure 5-19)

## **Removing the Backplane**

1. Turn off the computer, monitor, and then disconnect power from the computer.
2. Remove the outside cover.
3. Disconnect all power, video, disk and diskette cables.
4. Remove any expansion boards.
5. Remove the diskette drive.
6. Remove the main logic board.
7. Remove the screws.
8. Remove the backplane.

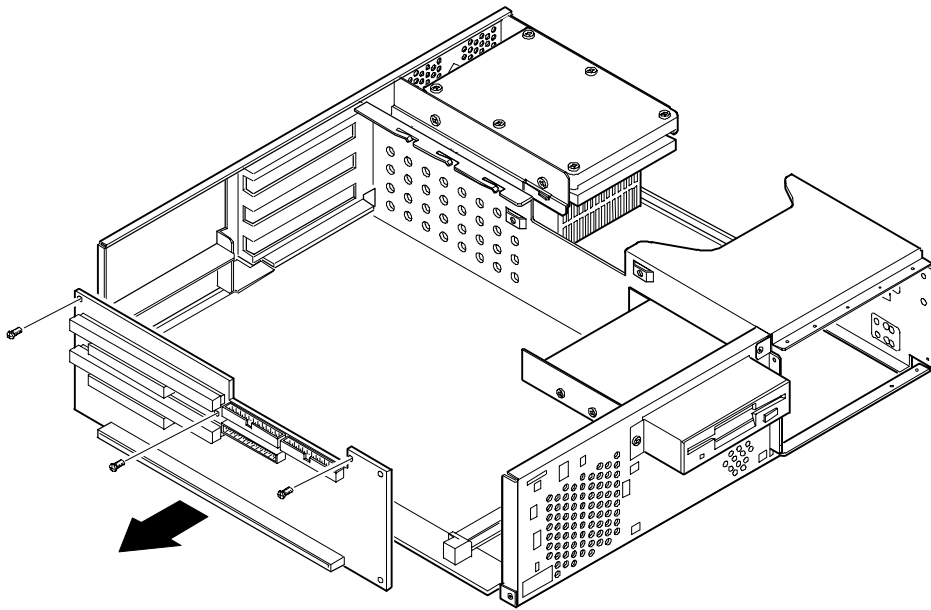

DEC01452

**Figure 5-21. Removing the Backplane**



## Removing Expansion Boards



**NOTE:** You do not have to remove the main logic board to remove an expansion board.

1. Turn off the computer, monitor, and then disconnect power from the computer.
2. Remove the outside cover.
3. Remove the screw.
4. Gently pull the expansion board from its socket.

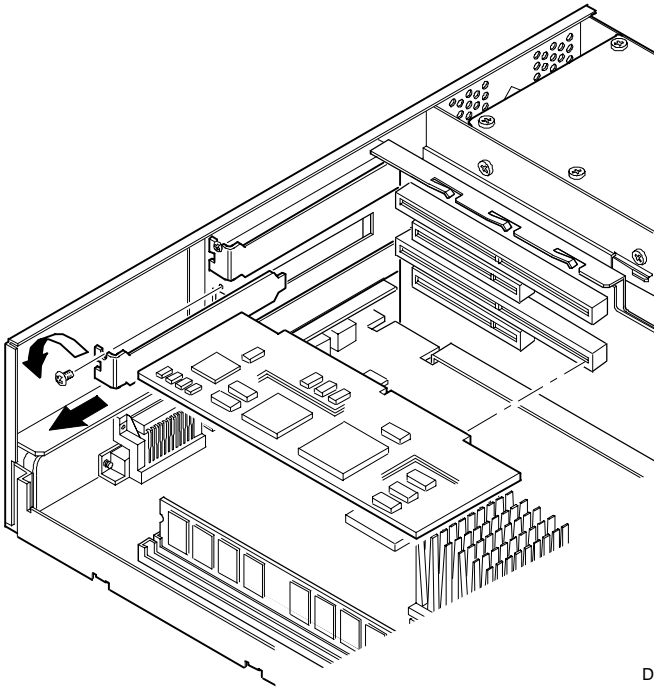

DEC01291-4

**Figure 5-23. Removing Expansion Boards**

## Removing the Power Supply

1. Turn off the computer, monitor, and then disconnect power from the computer.
2. Remove the outside cover.
3. Remove the internal hard disk drive.  
*Refer to "Removing Internal 3½-Inch Device."*
4. Disconnect the power cable from the backplane.
5. Disconnect all power cables from all devices.
6. Remove the screws.
7. Remove the power supply and bracket from the chassis.
8. Remove the bracket from the power supply.

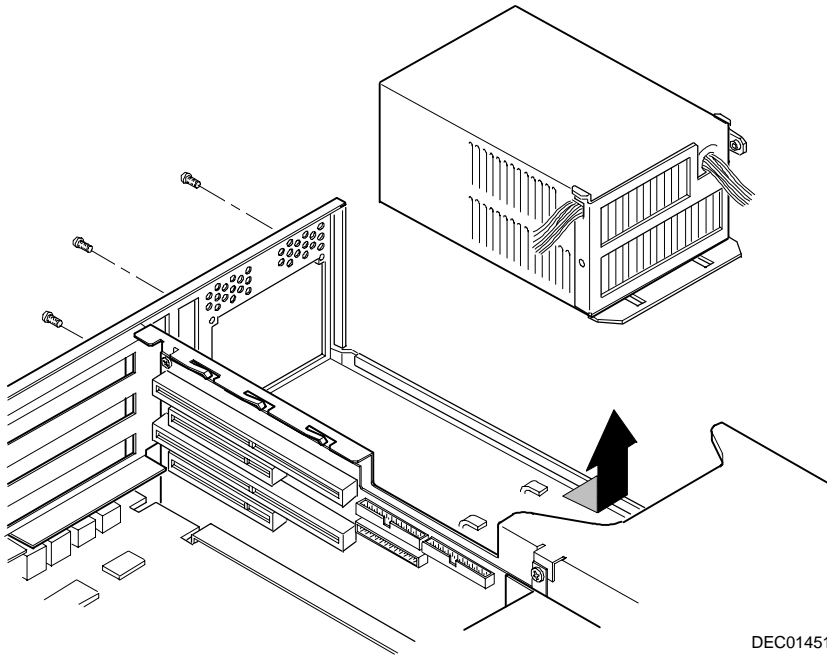

DEC01451

**Figure 5-24. Removing the Power Supply**

## Removing the Control Panel Assembly

1. Turn off the computer, monitor, and then disconnect power from the computer.
2. Remove the outside cover.
3. Remove the diskette drive and the bracket.  
*Refer to "Removing the Diskette Drive."*
4. Remove the main logic board.
5. Remove the main logic board guide.
6. Remove the screws securing the control panel assembly to the chassis.
7. Remove the control panel assembly.
8. Unplug the control panel cable from the backplane.

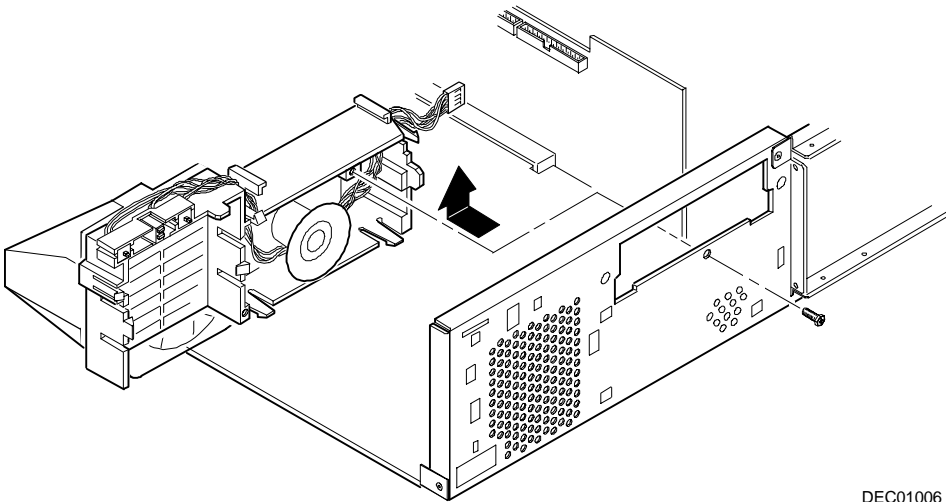

DEC01006

**Figure 5-26. Removing the Control Panel Assembly**

## Removing a 3½-Inch Device from the Front Bay

1. Turn off the computer, monitor, and then disconnect power from the computer.
2. Remove the outside cover.
3. Disconnect all power and data cables.
4. Remove the screws holding the drive to the bay.
5. Remove the 3½-inch device, which includes the rail and the brackets.
6. Remove the rail from the device.
7. Remove the brackets from the device.

## Parts Replacement

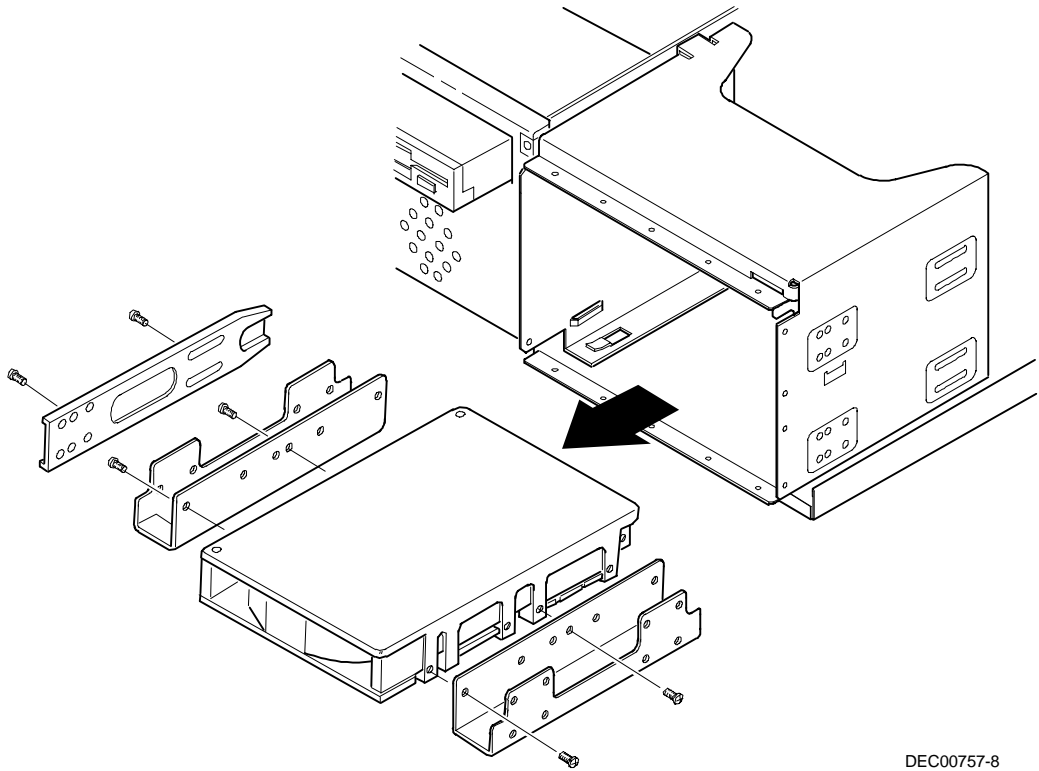

DEC00757-8

**Figure 5-32. Removing a 3 1/2-Inch Device from the Front Bay**

## Removing a 5¼-Inch Device from the Front Bay

1. Turn off the computer, monitor, and then disconnect power from the computer.
2. Remove the outside cover.
3. Disconnect all power and data cables.
4. Remove the screws holding the drive to the bay.
5. Remove the 5¼-inch device, which includes the rail.
6. Remove the rail from the device.



## Parts Replacement

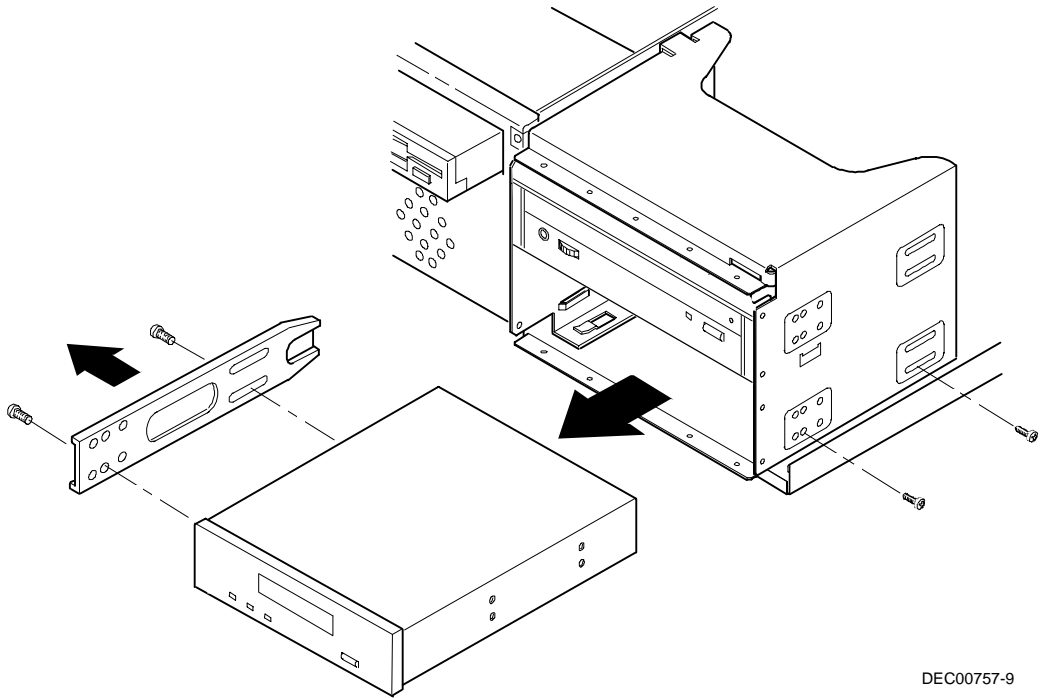

DEC00757-9

**Figure 5-33. Removing a 5 1/4-Inch Device from the Front Bay**

## Removing the Internal 3½-Inch Device

1. Turn off the computer, monitor, and then disconnect power from the computer.
2. Remove the outside cover.
3. Disconnect all power and data cables from the device.
4. Remove the screw from the bracket.
5. Remove the 3½-inch device with the bracket by sliding the device forward and lifting.
6. Remove the 3½-inch device from the bracket.

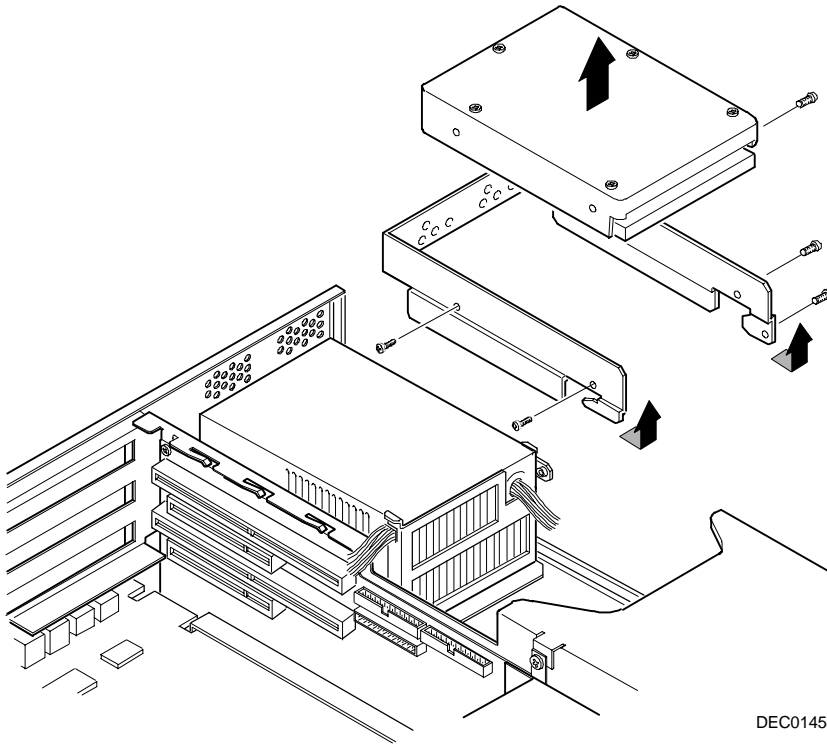

DEC01453

**Figure 5-38. Removing the Internal 3 1/2-Inch Device**

## Removing the Diskette Drive

1. Turn off the computer, monitor, and then disconnect power from the computer.
2. Remove the outside cover.
3. Remove all power and data cables from the diskette drive.
4. Remove the screws from the front holding the drive and the bracket in the bay.
5. Remove the diskette drive with the bracket.

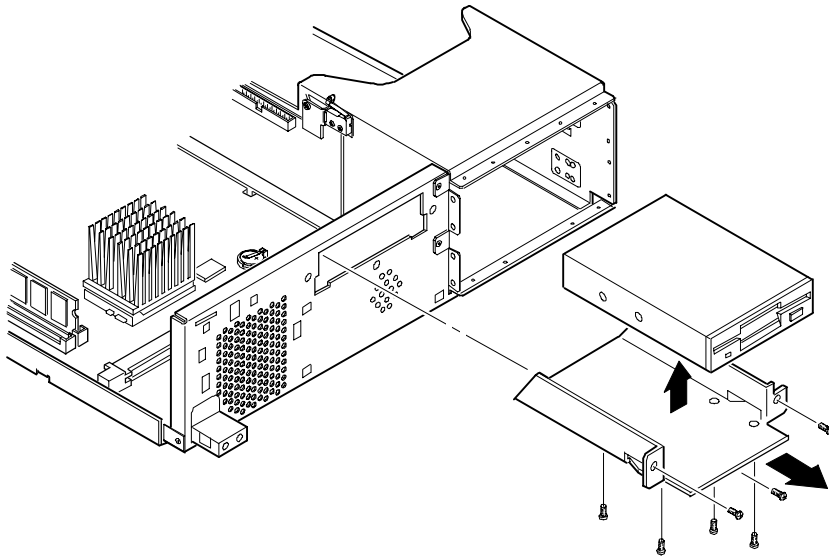

DEC01454

**Figure 5-39. Removing the Diskette Drive**

## Diskette and IDE Drive Data Cable Connectors

Figure Legend	Diskette Drive Component
A	Power supply
B	Power connections
C	Diskette drive connections
D	Backplane diskette drive connection
E	Diskette drive

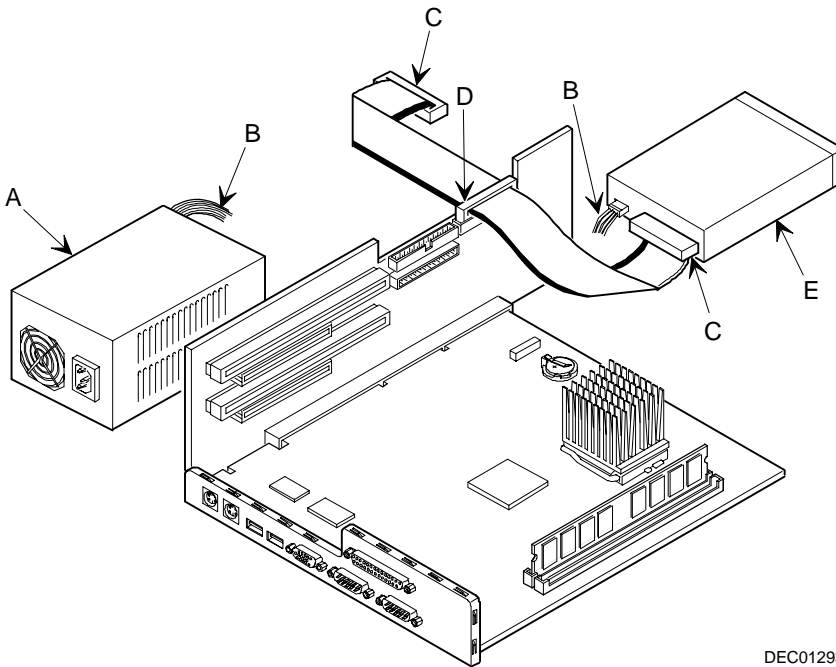

DEC01293

Figure 5-5. Diskette Drive Data Cable Connections

## Parts Replacement

<b>Figure Legend</b>	<b>IDE Drive Component</b>
A	Power supply
B	Primary IDE hard disk drive
C	Power connections
D	Primary IDE hard disk drive connections
E	Backplane IDE drive connection (primary)
F	Secondary IDE hard disk drive connections
G <sup>(1)</sup>	Optional CD-ROM drive
H	Backplane IDE drive connection (secondary)

<sup>(1)</sup> The optional CD-ROM drive is connected to the secondary IDE port and configured as a master drive.

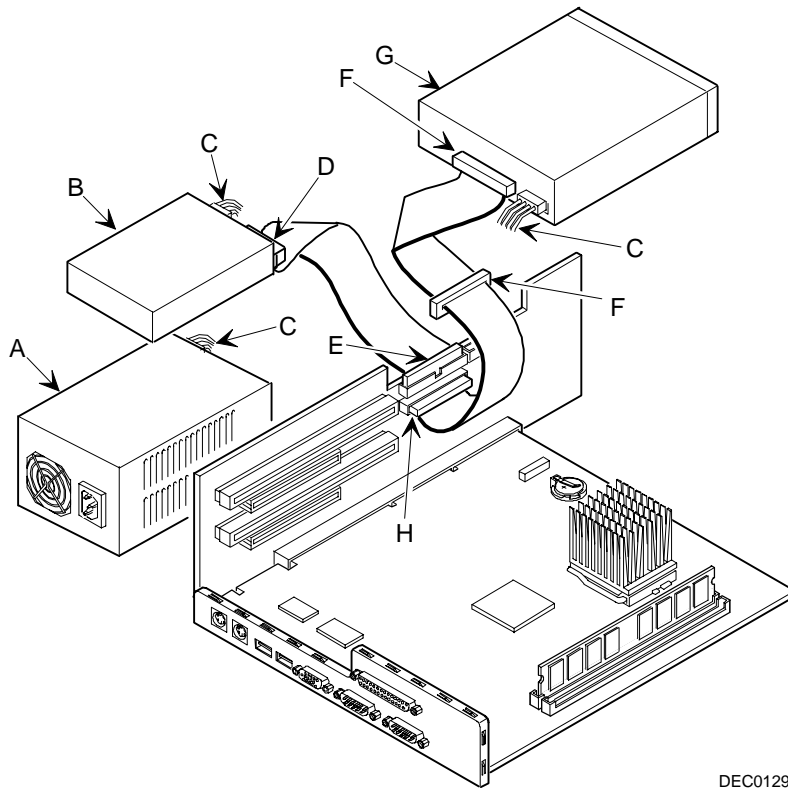

DEC01294

Figure 5-6. IDE Drive Data Cable Connections



## Introduction

This chapter provides a series of tables listing mapping and address information related to computer memory and various main logic board devices (keyboard controller, interrupt controller, DMA controller, etc.).

Your computer's memory and address locations are allocated at the factory to operate within a standard PC environment. However, due to the number of optional devices and/or expansion boards that are available, sometimes memory and address locations need to be changed. For example, some network expansion boards require a specific memory location. If that location is already allocated, a memory conflict results and the expansion board will not operate as expected. Note that some memory, I/O and interrupt locations can be changed using the BIOS Setup utility.

*Refer to Chapter 2, "The BIOS Setup Utility," for additional information.*



**CAUTION:** Before changing any memory or address location, refer to the documentation supplied with the optional device, expansion board, or software application and make sure adequate information is available. If not, contact the option or software manufacturer for further information.

## Full Range Processor Memory Address Map

Range	Function	Size
0000 to 9FFFFh	Base memory	640 KB
0A0000h to 0BFFFFh	Video RAM	128 KB
0C0000h to 0C7FFFh	Video BIOS	32 KB
0C8000h to 0DFFFFh	BIOS extension ROM (AT bus used)	96 KB
0E0000h to 0FFFFFFh	PnP BIOS/APM BIOS	128 KB
100000h to FFFFFFFh	Extended memory	255 MB

## I/O Address Map

Range (hexadecimal)	Function
000 - 00F	DMA controller one
020 - 021	Interrupt controller one
040 - 043	Interval timer
060 - 06F	Keyboard controller
070 - 071	Real-Time Clock (RTC), NMI
080 - 08F	DMA page register
0A0 - 0A1	Interrupt controller two
0C0 - 0CF	DMA controller two
0F0	Clear math co-processor busy
0F1	Reset math co-processor
0F8 - 0FF	Math co-processor
170 - 177	Secondary IDE controller
1F0 - 1F7	Primary IDE controller
278 - 27A	LPT2
2E8 - 2EF	COM4

*continued*

## Device Mapping

Range (hexadecimal)	Function
2F8 - 2FF	COM2
378 - 37A	LPT1
3BC - 3BE	LPT3
3E8 - 3EF	COM3
3F0 - 3F5	Diskette (floppy disk) controller
3F6	Primary/secondary IDE controller (alt status, device address)
3F7	Diskette (floppy disk) controller
3F8 - 3FF	COM1
4D0	Edge/level control register - INTCNTRL1
4D1	Edge/level control register - INTCNTRL2
CF8 - CFF	PCI configure space control register

## Computer Interrupt Levels

Interrupt Number	Interrupt Source
IRQ0	Timer tick
IRQ1	Keyboard controller
IRQ2	Cascade interrupt
IRQ3	COM2, COM4, if enabled
IRQ4	COM1, COM3, if enabled
IRQ5	Available
IRQ6	Diskette (floppy disk) drive, if enabled
IRQ7	LPT1, LPT3, if enabled
IRQ8	Real Time Clock (RTC)
IRQ9	VGA/USB
IRQ10	Available
IRQ11	Available
IRQ12	Mouse interrupt, if enabled
IRQ13	Math co-processor
IRQ14	IDE primary, if enabled
IRQ15	IDE secondary, if enabled

## DMA Channel Assignment

Channel	Controller	Function
0	1	Available
1	1	Available
2	1	Diskette (floppy disk) controller, if enabled
3	1	ECP, if enabled
4	2	Cascade DMA
5	2	Available
6	2	Available
7	2	Available

# Service Notes **A**

---

DIGITAL PC 3010

Service Notes





Service Notes