

System Board D2559 for TX150 S6

Technical Manual

Comments... Suggestions... Corrections...

The User Documentation Department would like to know your opinion of this manual. Your feedback helps us optimize our documentation to suit your individual needs.

Feel free to send us your comments by e-mail to manuals@fujitsu-siemens.com.

Certified documentation according to DIN EN ISO 9001:2000

To ensure a consistently high quality standard and user-friendliness, this documentation was created to meet the regulations of a quality management system which complies with the requirements of the standard DIN EN ISO 9001:2000.

cognitas. Gesellschaft für Technik-Dokumentation mbH
www.cognitas.de

Copyright and Trademarks

Copyright © 2007 Fujitsu Siemens Computers GmbH.

All rights reserved.

Delivery subject to availability; right of technical modifications reserved.

All hardware and software names used are trademarks of their respective manufacturers.

Contents

1	Introduction	5
<hr/>		
2	Important notes	7
<hr/>		
2.1	Notes on safety	7
2.2	CE Certificate	10
2.3	Environmental Protection	11
<hr/>		
3	Features	13
<hr/>		
3.1	Overview	13
3.2	Main memory	16
3.3	PCI bus	18
3.4	Screen resolution	20
3.5	Temperature / system monitoring	20
3.6	LEDs	22
3.7	Interfaces and connectors	24
3.7.1	External ports	25
3.8	Settings with jumpers	28
<hr/>		
4	Replacing the lithium battery	29
<hr/>		
	Abbreviations	31
<hr/>		

1 Introduction

This technical manual describes the system board D2559, which is equipped with one Intel® processor.

Further information about drivers is provided in the readme files on the hard disk, on the supplied “ServerStart“ or “Update“ CDs.

You will find further information in the BIOS description.

Notational conventions

The meanings of the symbols and fonts used in this manual are as follows:



<i>italics</i>	indicates commands, menu items, file and path names or software programs
fixed font	indicate system output on the monitor
semi-bold fixed font	indicates values to be entered through the keyboard
Key symbol	indicates keys according to their representation on the keyboard If capital letters are to be entered explicitly, then the Shift key is shown, e.g. SHIFT - A for A. If two keys need to be pressed at the same time, then this is shown by placing a hyphen between the two key symbols.
“quotation marks”	indicates names and terms that are being emphasized.
▶	indicates an operation that to be performed
 CAUTION!	indicates warnings, which, if ignored, will endanger your health, destroy the system or lead to the loss of data.
	indicates additional information, notes and tips

Table 1: Notational conventions

2 Important notes

In this chapter you will find essential information regarding safety when working with your server.



CAUTION!

With the system board installed you must open the system to access the system board. How to access the system board of your system is described in the appropriate service supplement.

When handling the system board, refer to the specific notes on safety in the operating manual and/or service supplement for the respective server.

2.1 Notes on safety



CAUTION!

- The actions described in these instructions should only be performed by authorized, qualified personnel. Equipment repairs should only be performed by qualified staff. Any failure to observe the guidelines in this manual, and any unauthorized openings and improper repairs could expose the user to risks (electric shock, fire hazards) and could also damage the equipment. Please note that any unauthorized openings of the device will result in the invalidation of the warranty and exclusion from all liability.
- Transport the device only in the antistatic original packaging or in packaging that protects it from knocks and jolts.
- Only install expansions that are allowed for the system board. If you install other expansions, you may damage the requirements and rules governing safety and electromagnetic compatibility or your system. Information on which system expansions are suitable can be obtained from the customer service centre or your sales outlet.
- The warranty expires if the device is damaged during the installation or replacement of system expansions.



- Components can become very hot during operation. Ensure you do not touch components when making extensions to the system board. There is a danger of burns!.
- Transmission lines to peripheral devices must be adequately shielded.
- To the LAN wiring the requirements apply in accordance with the standards EN 50173 and EN 50174-1/2. As minimum requirement the use of a protected LAN line of category 5 for 10/100 MBps Ethernet, and/or of category 5e for Gigabit Ethernet is considered. The requirements of the specification ISO/IEC 11801 are to be considered.
- Never connect or disconnect data transmission lines during a storm (lightning hazard).

Batteries



CAUTION!

- Incorrect replacement of lithium battery may lead to a risk of explosion. The batteries may only be replaced with identical batteries or with a type recommended by the manufacturer.

It is essential to observe the instructions in [chapter “Replacing the lithium battery”](#).

Modules with electrostatic-sensitive components

Systems and components that might be damaged by electrostatic discharge (ESD) are marked with the following label:

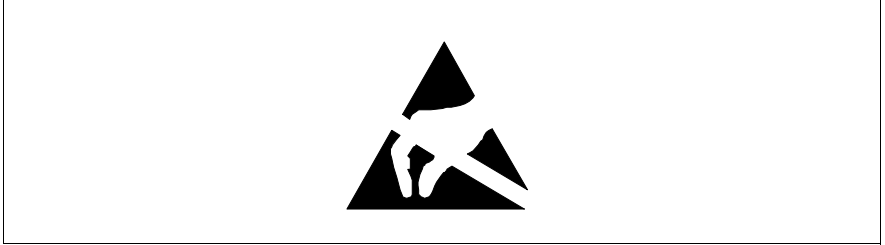



Figure 1: ESD label

When you handle components fitted with ESDs, you must observe the following points under all circumstances:

- You must always discharge yourself of static charges (e.g. by touching a grounded object) before working.
- The equipment and tools you use must be free of static charges.
- Remove the power plug from the power socket before inserting or removing boards containing ESDs.
- Always hold boards with ESDs by their edges.
- Never touch pins or conductors on boards fitted with ESDs.
- Use a grounding cable designed for this purpose to connect yourself to the system unit as you install/deinstall the board.
- Place all components on a static-safe base.

 You will find a detailed description for handling ESD components in the relevant European or international standards (EN 61340-5-1, ANSI/ESD S20.20).

Notes about boards

- During installation/deinstallation of the system board, observe the specific instructions described in the service manual for the server.
- Remove the plug from the mains outlet so that system and system board are totally disconnected from the mains voltage.
- To prevent damage to the system board, the components and conductors on it, please take great care when you insert or remove boards. Take great care to ensure that extension boards are slotted in straight, without damaging components or conductors on the system board, or any other components, for example EMI spring contacts
- Be careful with the locking mechanisms (catches, centring pins etc.) when you replace the system board or components on it, for example memory modules or processors.
- Never use sharp objects (screwdrivers) for leverage.

2.2 CE Certificate



The shipped version of this board complies with the requirements of the EEC directive 89/336/EEC "Electromagnetic compatibility".

Compliance was tested in a typical PRIMERGY configuration.

2.3 Environmental Protection

Environmentally friendly product design and development

This product has been designed in accordance with standards for "environmentally friendly product design and development". This means that the designers have taken into account important criteria such as durability, selection of materials and coding, emissions, packaging, the ease with which the product can be dismantled and the extent to which it can be recycled.

This saves resources and thus reduces the harm done to the environment.

Notes on saving energy

Devices that do not have to be on permanently should not be switched on until they need to be used and should be switched off during long breaks and on completion of work.

Notes on packaging

Please do not throw away the packaging. We recommend that you do not throw away the original packaging in case you need it later for transporting.

Notes on dealing with consumables

Please dispose batteries in accordance with local government regulations.

Do not throw batteries and accumulators into the household waste. They must be disposed of in accordance with local regulations concerning special waste.

All batteries containing pollutants are marked with a symbol (a crossed-out rubbish bin on wheels). In addition, the marking is provided with the chemical symbol of the heavy metal decisive for the classification as a pollutant:

Cd Cadmium

Hg Mercury

Pb Lead

Notes on labeling plastic housing parts

Please avoid attaching your own labels to plastic housing parts wherever possible, since this makes it difficult to recycle them.

Returning, recycling and disposal



The device may not be disposed of with household rubbish. This appliance is labelled in accordance with European Directive 2002/96/EC concerning used electrical and electronic appliances (waste electrical and electronic equipment - WEEE).

The guideline determines the framework for the return and recycling of used appliances as applicable throughout the EU. To return your used device, please use the return and collection systems available to you. You will find further information on this at www.fujitsu-siemens.com/recycling.

For details on returning and reuse of devices and consumables within Europe, refer to the "Returning used devices" manual, or contact your Fujitsu Siemens Computers branch office/subsidiary or our recycling centre in Paderborn:

Fujitsu Siemens Computers
Recycling Center
D-33106 Paderborn

Tel. +49 5251 8 18010

Fax +49 5251 8 18015

3 Features

3.1 Overview

Processor

- one Intel® Xeon™ processor
- processor socket LGA775 for Intel® Xeon™ processor with 800, 1066 or 1333 MHz Front Side Bus

Main memory

- four slots for main memory DDR2 667/800 MHz (unbuffered), SDRAM memory modules with 256 MB up to 4 Gbyte
- maximum 16 Gbyte of memory
- minimum 256 MB
- ECC multiple bit error detection and single bit error correction

Chips on the system board

- Intel® 3210 MCH north bridge
- Intel® ICH9R south bridge
- GBit LAN controller (Broadcom BCM5755T)
- Super-I/O controller (SMSC SCH5027)
- Flash EPROM for:
 - local BIOS update via bootable USB device or optional floppy disk
 - remote BIOS update via LAN
- iRMC chipset with integrated VGA graphic controller
- ADM7462 thermal system management controller

External connectors

- 4x UHCI USB 2.0
- serial port (COM1)
- serial port (COM2) (optional)
- parallel port (optional)
- 2x PS/2 ports for keyboard and mouse
- VGA
- RJ45 LAN
- RJ45 Service LAN

Internal connectors

- dual USB 2.0
- SATA (1-4) multilane
- 2x SATA
- floppy disk
- SAS/SATA/HD Activity LED
- front panel
- CPU fan 4 pins
- system fan 4 pins
- 4x system fans 5 pins
- PC98
- power (12V, -12V, 5V, 3.3V and 5V auxiliary)
- 12V (CPU) power
- intrusion detection
- SMB

PCI slots

- 3 x PCI (32 Bit / 33 MHz)
- 2 x PCI Express x8
- 1 x PCI Express x4

BIOS features

- Phoenix System BIOS V 6.00
- SMBIOS 2.34 (DMI)
- MultiProcessor specification 1.4
- Server Hardware Design Guide 3.0
- WfM 2.0
- ACPI 1.0b support with extensions from ACPI 2.0/3.0
- USB keyboard/mouse
- boot possible from:
 - 120 MB floppy disk drive or USB floppy disk drive
 - CD-ROM
 - USB 2.0 devices
 - LAN
- no Alert on LAN
 - console redirection support
- OEM logo
- memory disable

Environmental protection

Battery in holder for recycling

Form factor, slot compatibility list

- ATX dimension: 305 mm x 244 mm
- ACPI 1.0b, OnNow, PCI 2.3, PCI Express 1.0a, WfM 2.0, SHDG 3.0, MPS 1.4, IPMI 2.0, PCI SHPC 1.0, USB2.0

CSS (Customer Self Service)

This system board supports the CSS functionality. You will find a description of CSS functionality in the operating manual of your server.

TPM (option)

The system board is optional equipped with a TPM (Trusted Platform Module) by the manufacturer. This module enables programs from third party manufacturers to store key information (e.g. drive encryption using Windows Bitlocker Drive Encryption).

The TPM is activated via the BIOS system (for more information, refer to the Fujitsu Siemens Computers BIOS manual).



CAUTION!

- When using the TPM, note the program descriptions provided by the third party manufacturers.
- You must also create a backup of the TPM content. To do this, follow the third party manufacturer's instructions. Without this backup, if the TPM or the system board is faulty you will not be able to access your data.
- If a failure occurs, please inform your service about the TPM activation before it takes any action, and be prepared to provide them with your backup copies of the TPM content.

3.2 Main memory

The system board supports up to 16 Gbyte ECC main memory. 4 slots (2 memory banks with 2 modules) are available for the main memory. Each memory bank can be populated with 256 Mbyte, 512 Mbyte, 1 Gbyte, 2 Gbyte or 4 Gbyte unbuffered DDR2 memory modules.

ECC memory modules are supported only.



You will find the descriptions how to install memory modules in the Options Guide of your server.

Module population

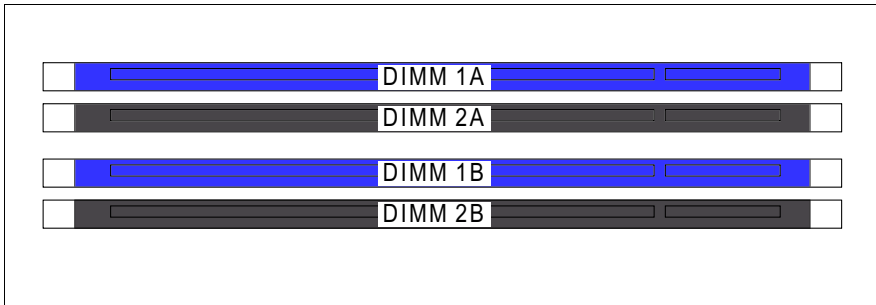

Figure 2: Main memory

- If the memory modules are populated in pairs, each pair must consist of identical memory modules (2-way interleaved mode).
- The module capacity between pairs can differ: pair 2A/2B can be populated with two 512 Mbyte memory modules and pair 1A/1B with two 1 Gbyte memory modules.

Following table shows examples for configurations

Mode	DIMM 1A (black)	DIMM 2A (blue)	DIMM 1B (black)	DIMM 2B (blue)
single-channel	populated	-	-	-
single/dual-channel ¹	populated	populated	populated	-
dual-channel	populated	-	populated	-
	populated	populated	populated	populated

¹ The dual-channel mode is only activated, if the size of the memory module in socket DIMM 2A is equal to the summary of the sizes of the memory modules in the sockets DIMM 1A and DIMM 1B.

Example: DIMM 1A = 512 MB, DIMM 1B = 512 MB, DIMM 2A = 1 GB

3.3 PCI bus

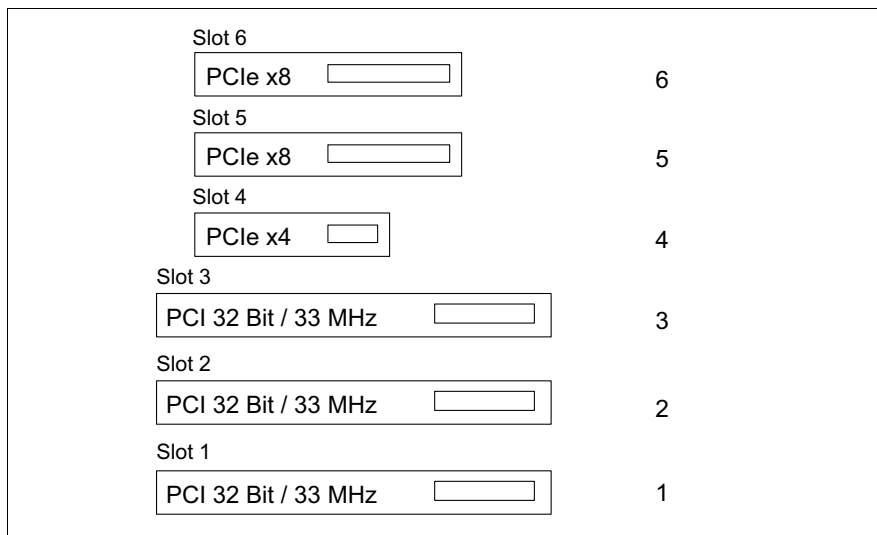

Figure 3: PCI slots

PCI slots

The following table shows an overview of the PCI slots:

PCI slot	32bit	Frequency in MHz	Description
1	32 bit	33	32 bit PCI slot
2	32 bit	33	32 bit PCI slot
3	32 bit	33	32 bit PCI slot
4			PCI e x4 slot
5			PCI e x8 slot
6			PCI e x8 slot

PCI, PCI Express interrupts

Each device connected to a PCI bus or PCI Express can use up to four interrupt signals depending on the functionality.

PCI and PCI-X buses use four lines named INTA to INTD, typically connected to all devices on the bus in order to periodically balance interrupt load. An interrupt signal may thereby be used simultaneously by multiple devices (interrupt sharing).

PCI Express devices send their interrupts through messages. This avoids restrictions in wiring.

The following interrupt signals are used in the system:

Slot/device	Property	Interrupt signal
VGA	iRMC graphic	Int B
LAN	BCM5755T	Int A
Slot 6	PCIe x8	Int A, B, C, D
Slot 5	PCIe x8	Int A, B, C, D
Slot 4	PCIe x4	Int A, B, C, D
Slot 3	PCI (33 MHz)	Int C, D, F, G
Slot 2	PCI (33 MHz)	Int F, G, C, D
Slot 1	PCI (33 MHz)	Int G, F, D, C

Assignment of the PCI interrupts

If you select *Auto* in the BIOS setup, the interrupts are assigned automatically and no further settings are required.

3.4 Screen resolution

Depending on the operating system used the screen resolutions in the following table refer to the graphic controller on the system board. The MATROX G200 graphic controller is integrated in the iRMC (integrated Remote Management Controller).

Screen resolution	Max. color depth	Max. frequency
640 x 480 Hz	32 Bit	85 Hz
800 x 600 Hz	32 Bit	85 Hz
1024 x 768 Hz	32 Bit	75 Hz
1152 x 864 Hz	24 Bit	60 Hz
1280 x 1024 Hz	24 Bit	60 Hz
1600 x 1200 Hz	16 Bit	60 Hz

If you are using an external graphic controller, you will find details of supported screen resolutions in the operating manual or technical manual supplied with the graphic controller.

3.5 Temperature / system monitoring

Temperature and system monitoring aim to reliably protect the computer hardware against damage caused by overheating. In addition, any unnecessary noise is also prevented by reducing the fan speed, and information is provided about the system status.

The temperature and system monitoring are controlled by an onboard controller.

The following functions are supported:

Temperature monitoring

Measurement of the processor and the system internal temperature by an onboard temperature sensor, measurement of the ambient temperature by a I²C temperature sensor.

Fan monitoring

The CPU, power supply unit and system fans are monitored. Fans that are no longer available, blocked or sticky fans are detected.

Fan control

The fans are regulated according to temperature.

Sensor monitoring

The removal of, or a fault in, a temperature sensor is detected. Should this happen all fans monitored by this sensor run at maximum speed, to achieve the greatest possible protection of the hardware.

Voltage monitoring

When voltage exceeds warning level high or falls below warning level low an alert will be generated.

Cover monitoring

Unauthorized opening of the cover is detected, even when the system is switched off. However, this will only be indicated when the system is switched on again.

System Event Log (SEL)

All monitored events of the system board are signaled via the Global Error LED and recorded in the System Event Log. They could be retrieved in the BIOS Setup or via ServerView.

3.6 LEDs

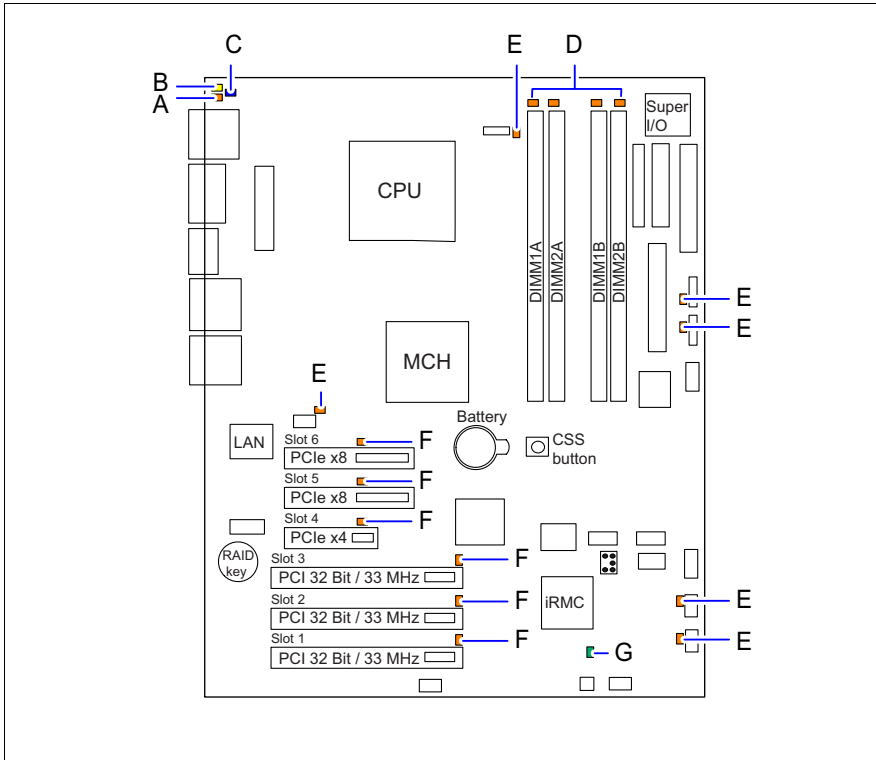

Figure 4: LEDs

LEDs A, B and C are visible from outside on the rear of the server. All the other LEDs are only visible, if the cover of the server has been opened.

The LEDs have the following meaning:

LED	Indicator	Meaning
A - GEL (Global Error LED)	amber	indicates a prefailure
	amber flashing	indicates a failure. Reasons for a failure may be: - overheating of one of the sensors - sensor defect - fan defect - CPU error - Software detected an error
B - CSS (Customer Self Service)	yellow	indicates a prefailure
	yellow flashing	indicates a failure
C - Identification	blue	server is identified via ServerView
D - memory	amber	memory module failure
E - CPU/system fans	amber	fan failure
F - controller	amber	controller failure
G - iRMC healthy	green blinking	iRMC (integrated Remote Management Controller) is okay

If the server has been powered off (power-plugs must be disconnected) it is possible to indicate the faulty component by pressing the CSS button.

3.7 Interfaces and connectors

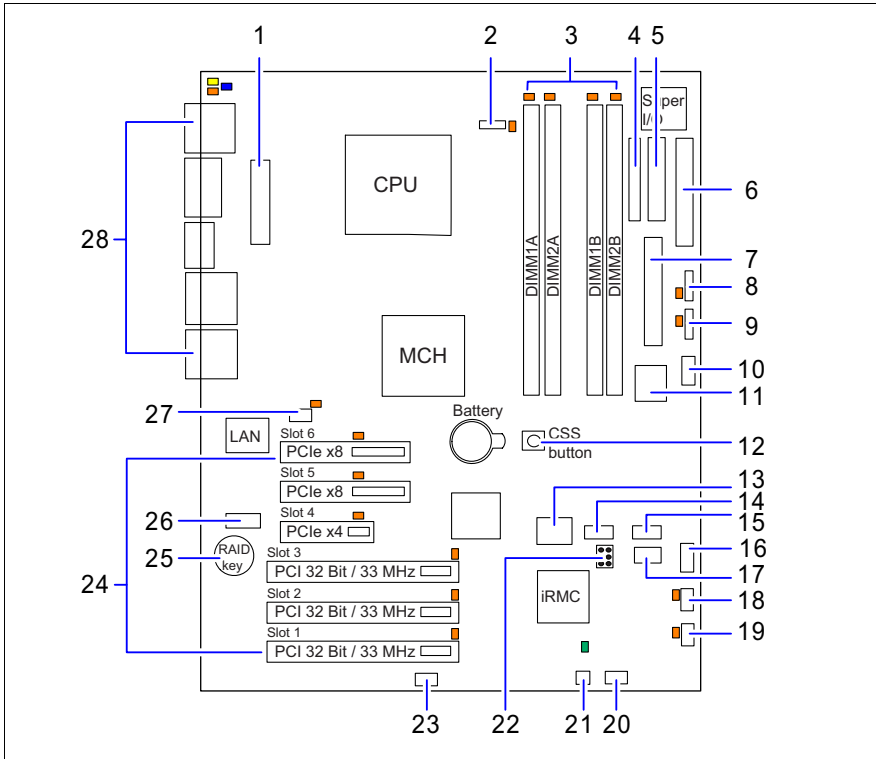

Figure 5: Schematic view of the system board D2559

- | | |
|-----------------------------------|----------------------------|
| 1 = parallel port (optional) | 15 = SATA 6 |
| 2 = CPU fan | 16 = USB DAT |
| 3 = slots for main memory modules | 17 = USB intern |
| 4 = PC98 | 18 = system fan 3 |
| 5 = front panel | 19 = system fan 2 |
| 6 = floppy disk drive | 20 = SMB1 |
| 7 = power supply ATX PWR1 | 21 = intrusion |
| 8 = system fan 5 | 22 = jumpers (see page 28) |
| 9 = system fan 4 | 23 = HDD activity |

10 = USB	24 = PCI slots
11 = power supply ATX 12V	25 = RAID key
12 = CSS button	26 = serial interface 2
13 = Mini SAS	27 = system fan 1
14 = SATA 5	28 = external ports

RAID key

The SATA SW RAID 5 functionality will be activated by installing a license key (RAID key).

3.7.1 External ports

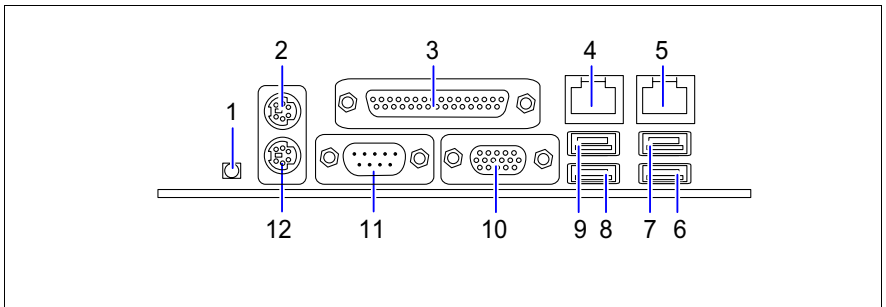

Figure 6: External ports of the system board D2559

1 = CSS LED (yellow)/ Global Error LED (amber)/ Identification LED (blue)	7 = USB port 2
2 = PS/2 mouse connector	8 = USB port 3
3 = parallel interface (optional)	9 = USB port 4
4 = service LAN connector	10 = VGA port
5 = system LAN connector	11 = serial interface COM1
6 = USB port 1	12 = PS/2 keyboard connector

The serial interface COM1 can be used as default interface or to communicate with the iRMC.

LAN connectors

On this system board you will find two LAN controllers: a Gigabit LAN controller (Broadcom BCM5755T) and a service LAN controller.

The Gigabit LAN controller BCM5755T supports the transfer rates of 10 Mbit/s, 100 Mbit/s and 1 Gbit/s. The Service LAN controller supports the transfer rates of 10 Mbit/s and 100 Mbit/s.

The LAN controllers support WOL function through Magic Packet™.

It is also possible to boot a device without its own boot hard disk via LAN. Here Intel PXE is supported.

The service LAN port serves as management interface and is prepared for RemoteView.

The LAN connectors are equipped each with two LEDs (light emitting diode) indicating the transfer rate and the activity.

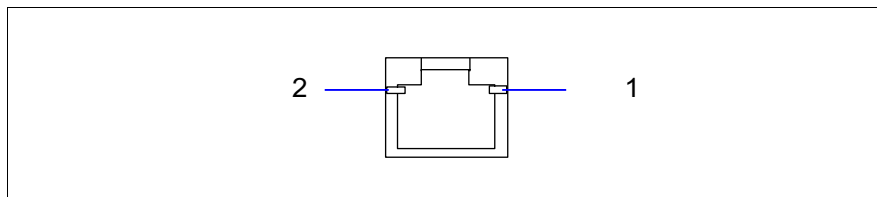

Figure 7: LAN connector system LAN controller

1	LAN transfer rate	green + yellow	off	transfer rate 10 Mbit/s
		green	on	transfer rate 100 Mbit/s
		yellow	on	transfer rate 1000 Mbit/s
2	LAN link/activity	green	on	LAN connection
			off	no LAN connection
			flashing	LAN transfer

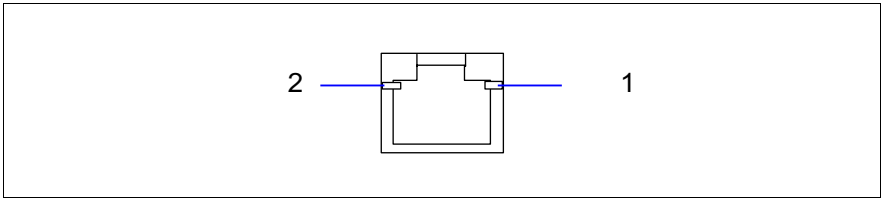

Figure 8: LAN connector service LAN controller

1	LAN transfer rate	green	off	transfer rate 10 Mbit/s
		green	on	transfer rate 100 Mbit/s
2	LAN link/activity	green	on	LAN connection
			off	no LAN connection
			flashing	LAN transfer

3.8 Settings with jumpers

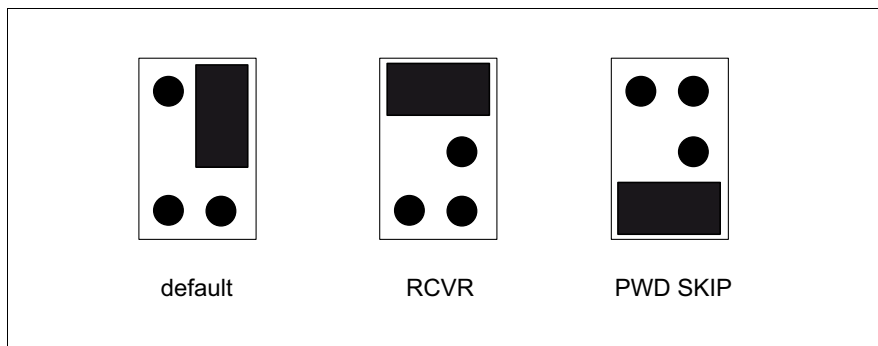

Figure 9: Jumpers

Recovering system BIOS - jumper RCVR

RCVR enables recovery of the old system BIOS after an attempt to update has failed. To restore the old system BIOS you need a Flash BIOS Diskette (please call our customer service centre).

being set The system boots from the “Flash BIOS floppy disk“ from drive A and reprograms the system BIOS on the board.

default The System BIOS is started with the system BIOS from the system board (default setting).

Skipping the password query - jumper PWD SKIP

PWD SKIP is used to define whether the password is queried at system startup, if the password protection is enabled in BIOS Setup (in *Security* menu, the *Password* field must be set to *Enabled*).

being set The password query is skipped. Passwords are deleted.

default The password query is effective (default setting).

4 Replacing the lithium battery

In order to save the system information permanently, a lithium battery is installed to provide the CMOS-memory with a current. When the charge is too low or the battery is empty, a corresponding error message is provided. The lithium battery must then be replaced.



The lithium battery must be replaced with an identical battery or a battery type recommended by the manufacturer (CR2032).

Do not throw lithium batteries into the trash can. It must be disposed of in accordance with local regulations concerning special waste.

Make sure that you insert the battery the right way round. The plus pole must be on the top!

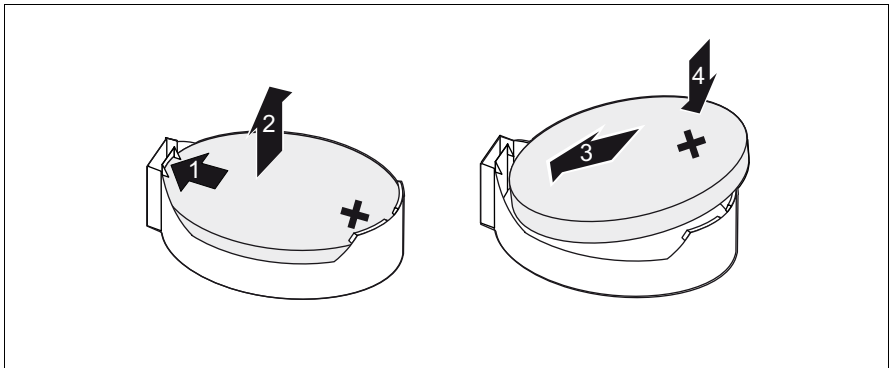

Figure 10: Replacing the lithium battery

- ▶ Press the locking spring into direction of the arrow (1), so that the lithium battery jumps out of its socket.
- ▶ Remove the battery (2).
- ▶ Insert a new lithium battery of the same type into the socket (3) and (4).

Abbreviations

The technical terms and abbreviations given below represent only a selection of the full list of common technical terms and abbreviations.

Not all technical terms and abbreviations listed here are valid for the described system board.

ACPI

Advanced Configuration and Power Interface

ASR&R

Automatic Server Recovery and Restart

ATA

Advanced Technology Attachment

BBU

Battery Backup Unit

BIOS

Basic Input Output System

BMC

Baseboard Management Controller

CMOS

Complementary Metal Oxide Semiconductor

COM

COMmunication port

CPU

Central Processing Unit

DDR

Double Data Rate

DIMM

Dual In-line Memory Module

Abbreviations

DIP

Dual In-line Package

DMI

Desktop Management Interface

DRAM

Dynamic Random Access Memory

ECC

Error Correction Code

EEPROM

Electrical Erasable Programmable Read Only Memory

EPROM

Erasable Programmable Read Only Memory

EMRL

Embedded RAID Logic

EVRD

Enterprise VRD

HPC

Hot-plug Controller

ICE

In Circuit Emulation

IDE

Integrated (intelligent) Drive Electronics

IME

Integrated Mirror Enhanced

IOOP

Intelligent Organization Of PCI

IPMB

Intelligent Platform Management Bus

IPMI	Intelligent Platform Management Interface
iRMC	integrated Remote Management Controller
LAN	Local Area Network
LED	Light Emitting Diode
MPS	Multi Processor Specification
NMI	Non Maskable Interrupt
OEM	Original Equipment Manufacturer
OHCI	Open Host Controller Interface
OS	Operating System
PCI	Peripheral Components Interconnect
PDA	Prefailure Detection and Analyzing
PIO	Programmed Input Output
PLD	Programmable Logic Device
PS(U)	Power Supply (Unit)

Abbreviations

PWM

Puls Wide Modulation

PXE

Preboot eXecution Environment

RAID

Redundant Array of Inexpensive Disks

RSB

Remote Service Board

RST

ReSeT

RTC

Real Time Clock

SAS

Serial Attached SCSI

SATA

Serial ATA

SCSI

Small Computer Systems Interface

SDDC

Single Device Data Correction

SDRAM

Synchronous Dynamic Random Access Memory

SHDG

Server Hardware Design Guide

SMB

System Management Bus

SMM

Server Management Mode

SMP
Symmetrically Multi Processing

UHCI
Unified Host Controller Interface

USB
Universal Serial Bus

VGA
Video Graphics Adapter

VRD
Voltage Regulator Down

VRM
Voltage Regulator Module

WfM
Wired for Management

WOL
Wake up On LAN



Information on this document

On April 1, 2009, Fujitsu became the sole owner of Fujitsu Siemens Computers. This new subsidiary of Fujitsu has been renamed Fujitsu Technology Solutions.

This document from the document archive refers to a product version which was released a considerable time ago or which is no longer marketed.

Please note that all company references and copyrights in this document have been legally transferred to Fujitsu Technology Solutions.

Contact and support addresses will now be offered by Fujitsu Technology Solutions and have the format ...@ts.fujitsu.com.

The Internet pages of Fujitsu Technology Solutions are available at [http://ts.fujitsu.com/...](http://ts.fujitsu.com/) and the user documentation at <http://manuals.ts.fujitsu.com>.

Copyright Fujitsu Technology Solutions, 2009

Hinweise zum vorliegenden Dokument

Zum 1. April 2009 ist Fujitsu Siemens Computers in den alleinigen Besitz von Fujitsu übergegangen. Diese neue Tochtergesellschaft von Fujitsu trägt seitdem den Namen Fujitsu Technology Solutions.

Das vorliegende Dokument aus dem Dokumentenarchiv bezieht sich auf eine bereits vor längerer Zeit freigegebene oder nicht mehr im Vertrieb befindliche Produktversion.

Bitte beachten Sie, dass alle Firmenbezüge und Copyrights im vorliegenden Dokument rechtlich auf Fujitsu Technology Solutions übergegangen sind.

Kontakt- und Supportadressen werden nun von Fujitsu Technology Solutions angeboten und haben die Form ...@ts.fujitsu.com.

Die Internetseiten von Fujitsu Technology Solutions finden Sie unter [http://de.ts.fujitsu.com/...](http://de.ts.fujitsu.com/), und unter <http://manuals.ts.fujitsu.com> finden Sie die Benutzerdokumentation.

Copyright Fujitsu Technology Solutions, 2009