



Alpha PCI 164-266/300 P2.2 Motherboard Terms of Usage

Use the Alpha PCI 164-266/300 P2.2 motherboard for bounded use applications only. Examples of suitable use include an embedded printer controller, disk drive controller, or other limited application environments. The application must be approved by OEM Business Segment Marketing and pass a qualification test. Unauthorized use of the motherboard voids the warranty.

Digital restricts the use of this motherboard because of a behavior anomaly in the Pass P2.2 Alpha 21164 processor chip used on it. Applications executing within the limits of the processor chip will experience no problem.

The figure below lists Alpha 21164 P2.2 chip identification codes covered by this restriction.

Alpha 21164 Part Branding

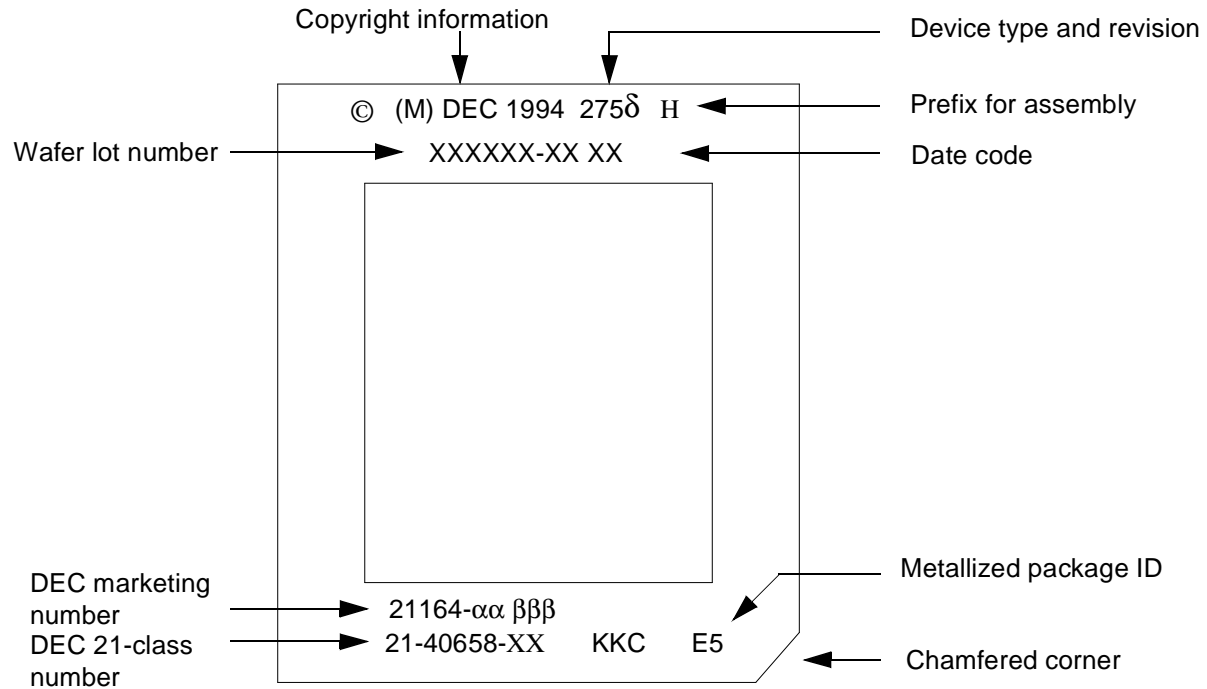

$\alpha\alpha$	$\beta\beta\beta$	$\chi\chi$	δ	Comments	Pass	MHz
AA	266	07	C	Restricted use	2.2	266
BA	300	09	C	Restricted use	2.2	300

You can identify the chip from software by reading the EI_STAT register. The EI_STAT<CHIP_ID> field is 2 on P2.2 parts and 4 on P4.0 parts.