

Handling Precautions



CAUTION

High potential static charge can cause damage to the integrated circuits on the board. Before handling any mainboard outside of its protective packaging, ensure that there is no static electric charge on your body.

Danger of explosion if battery is incorrectly replaced. Replace only with the same or equivalent type recommended by the manufacturer.

There are some basic precautions when handling the motherboard or other computer components:

- ◆ Keep the board in its anti-static bag until you are ready to install it.
- ◆ Protect your board from static electricity by well grounding of your body and the equipment during the installation, such as wearing a grounded wrist strap.
- ◆ Always handle the board by its edges.
- ◆ Do not touch with the components on the boards, add-on cards and modules, or the “gold finger” connectors going to be plugged into the expansion slot. It is best to handle system components by their mounting bracket.
- ◆ Ensure the system power is completely turn-off before doing any installation work.

Notice to Customers

The information contained in this User's Guide with no liability whatsoever, and disclaims any express or implied warranty, relating to sale and/or use of products including liability or warranties relating to fitness for a particular purpose, merchantability, or infringement of any patent, copyright or other intellectual property right. We shall not be liable for any loss or profits, loss of business, loss of use or data, interruption of business, or for indirect, special, incidental, or consequential damages arising from any defect or error in this User's Guide or product.

We retains the right to make changes on this User's Guide and product descriptions at any time, without notice.



Trademarks™

Intel® Pentium® are registered trademarks of Intel Corporation.

IBM, IBM PC, IBM PC/AT ,PC-DOS, OS/2 and OS/2 WARP are registered trademarks of International Business Machines Corporation.

MS-DOS, Windows and Windows 95 are registered trademarks of Microsoft Corporation.

AMI BIOS is a product of American Megatrends Inc.

Sound Blaster and Blaster are registered trademarks in U.S.A. and/or other countries.

SB-LINK DynaRAM and WavEffects are trademarks of Creative Technology Ltd.

Third-party brands and names mentions in this User's Guide are the property of their respective owners.

User's Guide Revision : 1.0

Release Date : January 1998

Copyright © 1998, All rights reserved.



Table of Contents

FEATURES OF THE BOARD.....	1
OVERVIEW	1
AUTO JUMPER YES	1
FEATURES SUMMARY	1
MOTHERBOARD INSTALLATION.....	3
INSTALLATION PRECAUTIONS.....	3
A QUICK INTRODUCTION	3
JUMPERS SETTING	3
CPU INSTALLATION.....	4
INSTALLING SYSTEM MEMORY (RAM).....	5
EXPANSION CARDS INSTALLATION.....	7
CONNECTING EXTERNAL CONNECTOR	7
REPLACING BATTERY.....	10
QUICK INSTALLATION GUIDE.....	11
QUICK REFERENCE OF YOUR MOTHERBOARD	15
MOTHERBOARD TECHNICAL SPECIFICATION.....	19
ENVIRONMENT	19
DIMENSIONS AND WEIGHT.....	19
ELECTRICAL SPECIFICATION	19
POWER CONSUMPTION.....	19
REQUEST FOR TECHNICAL SUPPORT	20

Features of the Board

Overview

Congratulations on purchasing the highest performance Pentium® motherboard. With the advanced technology available today, this motherboard is designed to run Intel's Pentium® processors at speeds up to 233 MHz. The on-board system memory consists of SIMM and DIMM giving you the most flexibility for system design. It supports up to 128 MB of DRAM using standard 72-pin SIMM sockets that accept either Fast Page Mode (FPM) or Extended Data Out (EDO) memory. In addition, two unbuffered, 3.3 Volts, 168-pin SDRAM sockets are also included for 16 to 256MB synchronous Dynamic memory support. A 321-pins type 7, Zero Insertion Force (ZIF) socket allows an easy upgrade path for the future Pentium Overdrive® processors.

The motherboard uses VIA VT82C597AT AGP/PCI chipset. The VIA VT82C586B PCI/ISA Bridge provides an integrated Bus Mastering IDE controller with two high performance UltraDMA-33 EIDE interfaces for up to four IDE devices (such as hard drives or CD-ROM). The PCI/ISA Bridge also includes an USB interface. The integrated I/O controller integrates the standard PC I/O functions: floppy interface, two FIFO serial ports, one EPP/ECP capable parallel port, and support for an IrDA and Consumer Infra Red compatible interface.

Three on-board 32-bit PCI local bus slots allow a higher bandwidth data path, which serves as a super highway for intensive data-movement such as video or networking. The BIOS support PCI bridge user configuration, which allows further expansion of the system with PCI peripherals. Up to three 16-bit ISA slots is provided so that the board is backward hardware compatible with the older expansion card. A total of six expansion slots can be populated with add-in cards as one PCI and ISA slots share the same chassis I/O panel. (Two full lengths ISA add-in cards can be installed while the third can be half-length. All PCI cards can be full lengths.)

Auto Jumper Yes

This motherboard (**SDLX-TC**) is within one of our "Auto Jumper Yes" series, which eliminates the necessity for the user to be bored by jumper settings on the motherboard. It is capable of detecting the CPU brand, and setting the appropriate CPU core voltage and speed according to instructions from the user through CMOS setup menu. In contrast to "Jumperless", "Auto Jumper Yes" allows switching to manual mode that enables physical jumpers on the mainboard, so as to prevent the potential impacts on jumperless boards from the future CPU specifications. On the other hand, pressing "F" to clear CMOS setting and "J" to re-detect CPU during power on the system, to avoid the difficulties to reset the CMOS data.

Features Summary

This motherboard comes with following features:

- Supports Intel Pentium® Processor up to 233MHz, which included the newest MMX CPU.
- VIA VP3 AGP/ PCIset**, including a **VT82C597AT** AGP/PCI/Memory/Data controller , and 82C586B PCI ISA IDE Accelerator.
- WAKEUP-LINK interface header supporting Intel Wake-On-LAN
- TB-LINK interface headers supporting TOMATO™ SCV6 sound card using the Creative™ Audio chip.

- Supports “Modems Ring On” (Requires ATX power supply and External modem)
- PnP BIOS with support for power management, UltraDMA33/EIDE/SCSI features and desktop management interface (DMI) which allows higher level of hardware compatibility.
- CPU fan will power off and blinking LED automatically in sleep mode
- Flash BIOS for easy upgrade
- Two 72-pin SIMM sockets, supports up to 128 MB DRAM in two banks, which included FPM, EDO DRAM types
- The total of two high speed unbuffered SDRAM sockets, supports 16-256M memory.
- Three 16-bit ISA expansion slots and three 32-bit PCI expansion slots.
- Integrated two PCI bus master UltraDMA-33 EIDE controller with two on-board connectors supports up to four IDE devices such as Hard Disk, CD-ROM or Tape Backup drives. USB interface also provided.
- Integrated I/O chipset featuring one floppy disk controller, two 16550 UART compatible serial ports, one high speed EPP/ECP capable parallel port, one Infra Red port.
- One Accelerated graphic port (AGP) for AGP card.

Motherboard Installation

INSTALLATION PRECAUTIONS

During installation and initial test, use caution to avoid personal injury and damage to wiring due to sharp pins on connectors and printed circuit assemblies, rough chassis edges and corners, and hot components. Adhere to warnings and limitations regarding accessibility into areas designated only for authorized technical personnel.

A QUICK INTRODUCTION



To install and operate your new motherboard, you must follow the steps below:

1. Set Jumpers on the motherboard
2. Install the CPU with cooling fan
3. Install RAM modules
4. Connect cables, wires and power connector
5. Install expansion cards

Jumpers Setting

There are several user-adjustable jumpers on the board which allow you to configure your system to match your requirements. This chapter contains the information on the various jumpers settings and connector on your motherboard.

Jumpers

Jumpers are used to make several hardware settings on the motherboard. From the “Map of the Motherboard” shown above, you can identify the location of the jumpers. There are two kinds of jumper on-board, 2-pin jumper and 3-pin jumper. On the symbol of jumper like “”, “” inside stands for pin 1. To set a jumper, a black cap containing metal contacts is placed across the jumper pin/s according to your required configuration. The jumper settings will also be described numerically such as [open] for open, [short] for short, [1-2] for connect pins 1&2, [2-3] for connects pins 2&3 respectively.

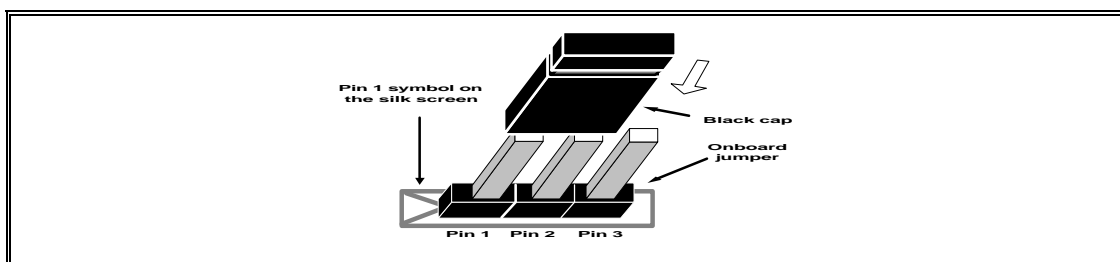

CAUTION

Users are not recommended to change any jumpers in its default setting listed on this User's Guide. Changing the jumper settings improperly may affect the system performance.

CPU Installation

The motherboard provides a 321-pins, type-7, ZIP socket. The CPU should have a fan attached to it to prevent overheating. If this is not the case then purchase a fan before you turn-on the system.

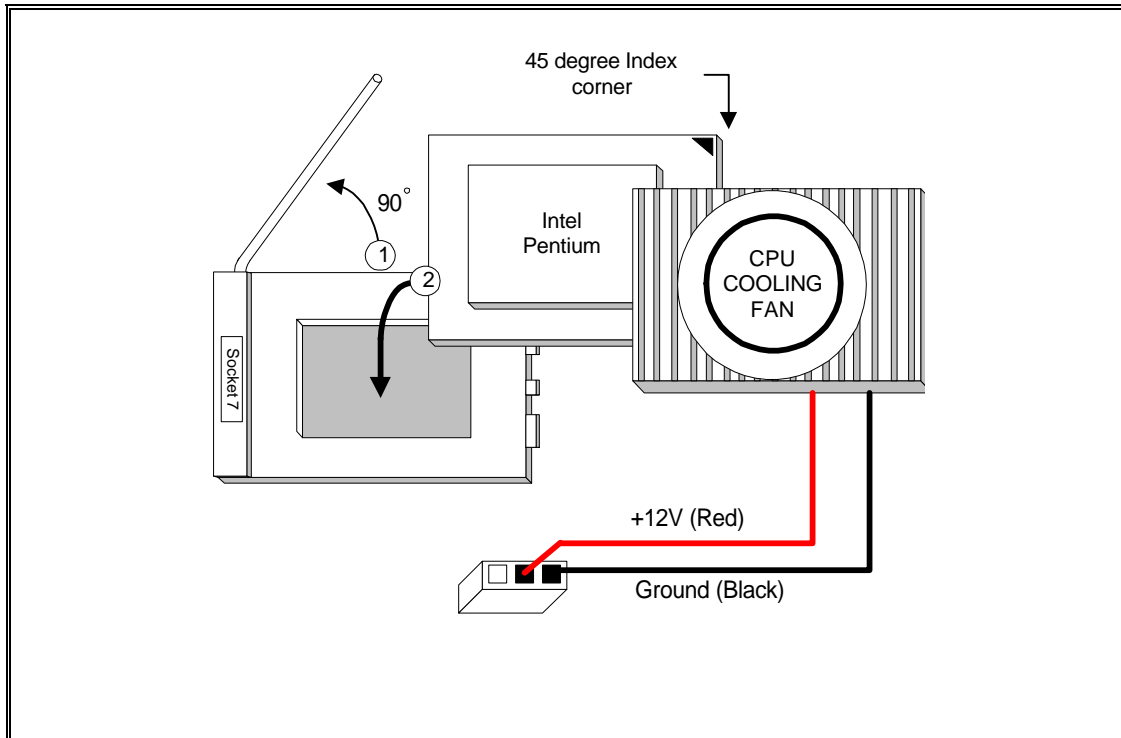

CPU Installation Diagram

! CAUTION

Without a effective cooling fan, the CPU can overheat and cause damage to both the CPU and the motherboard.

INSTALLING SYSTEM MEMORY (RAM)

The motherboard supports two 72-pin SIMMs (Single-In-Line Memory Modules) from 8MB up to 256MB memory size and two 168-pin DIMM.

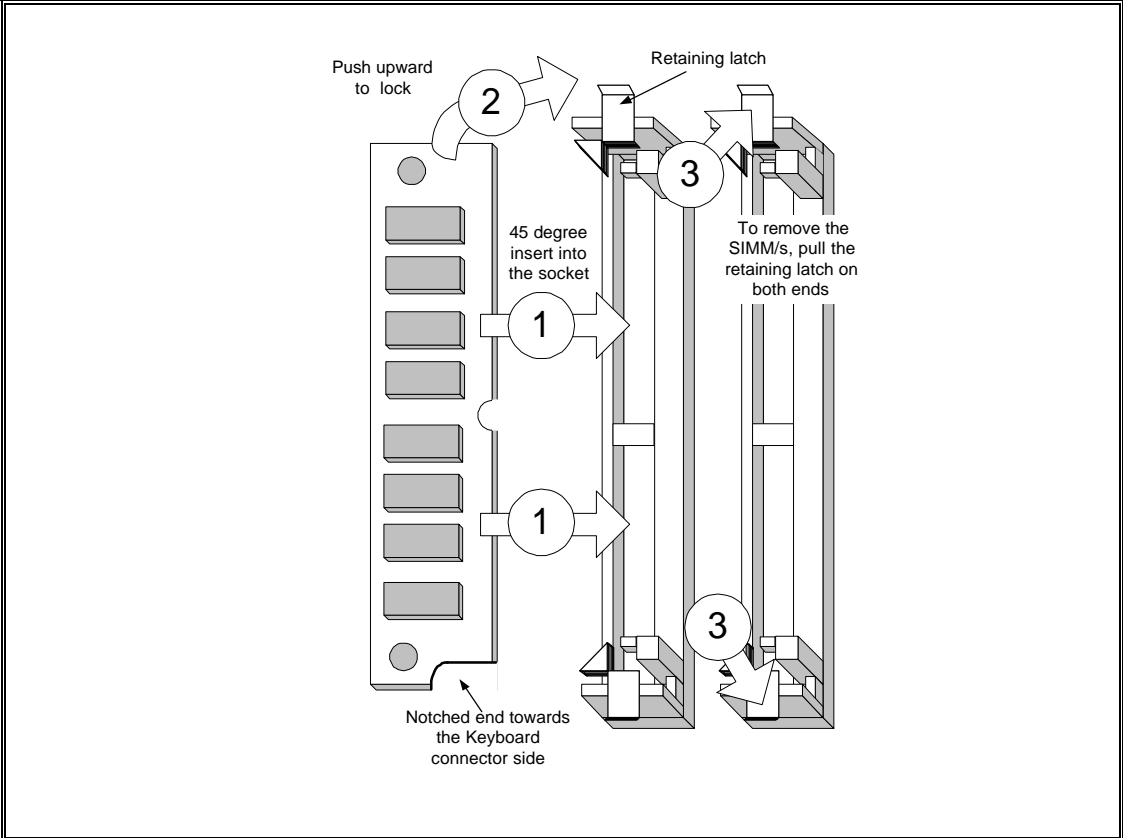

SIMM Module Installation Diagram

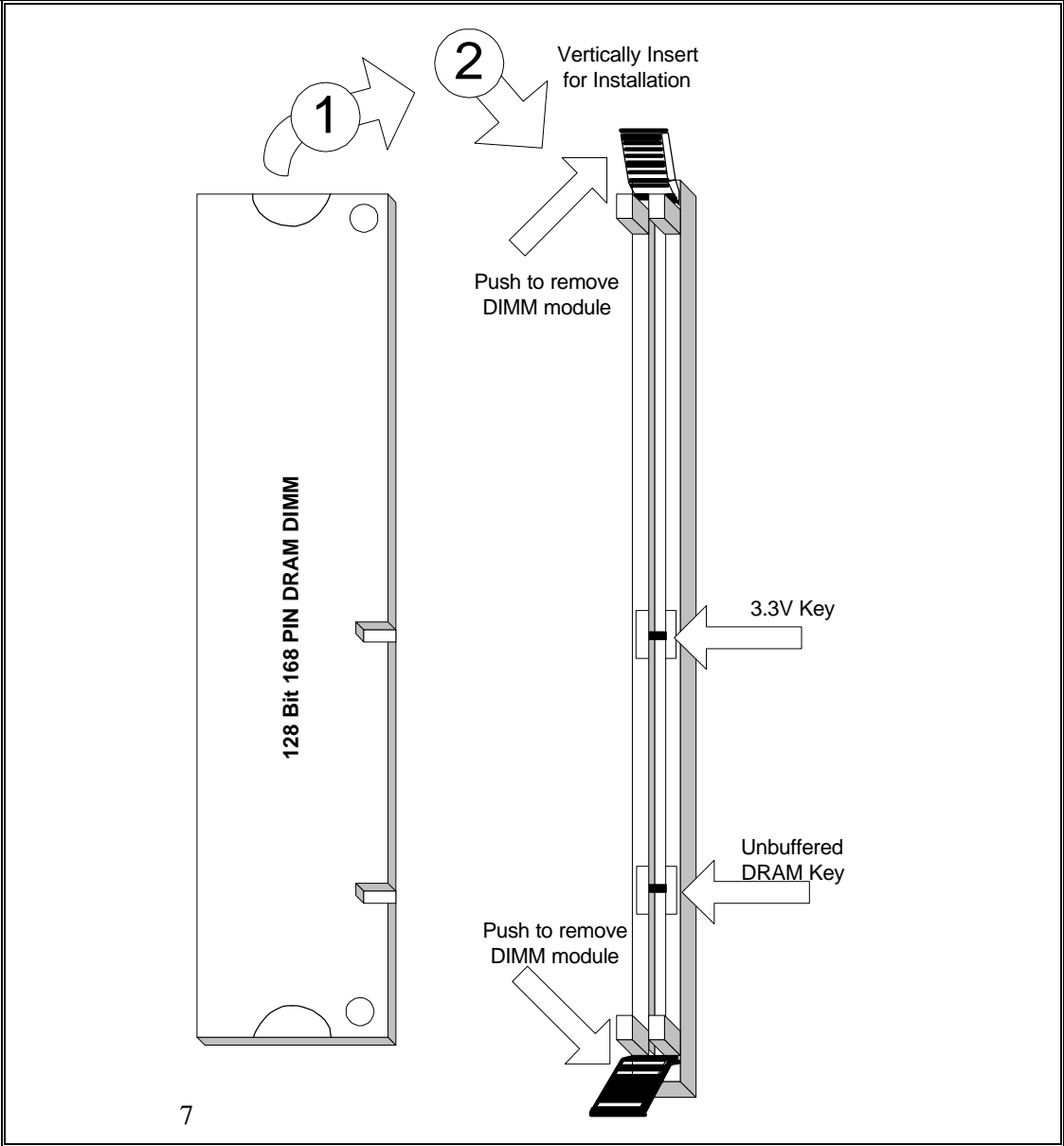

168-Pin SDRAM Module Installation Diagram

EXPANSION CARDS INSTALLATION

At the most of beginning, you must read your expansion card documentation on any hardware and software settings that may be required. The installation procedures are summarized as below:

1. Read the User's Guide/Manual of your expansion card.
2. If necessary, set any jumpers on your expansion card.
3. Power-off the system and then disconnected the power cord.
4. Remove your computer's cover.
5. Remove the metal bracket from one of the empty slot, ISA or PCI, corresponding to the type of expansion card.
6. Carefully align the card's connectors and press firmly, make sure that the connection is good.
7. Secure the card on the slot.
8. Replace the computer's cover.
9. Setup the BIOS configuration if necessary.
10. Install the required software drivers for your expansion card.

CAUTION

Before adding or removing any expansion card or other system components, make sure that you unplug your system power supply. Failure to do so may cause damage of your motherboard and expansion cards.

CONNECTING EXTERNAL CONNECTOR

AT Power Connector

A 12-Pin power supplies provide two plugs incorporates standard $\pm 5V$ and $\pm 12V$, each containing six wires, two of which are black. Orient the connectors so that the black wires are together.

Pin	Signal Name	Pin	Signal Name
1	Power Good Signal	7	Ground
2	+5V	8	Ground
3	+12V	9	-5V
4	-12V	10	+5V
5	Ground	11	+5V
6	Ground	12	+5V

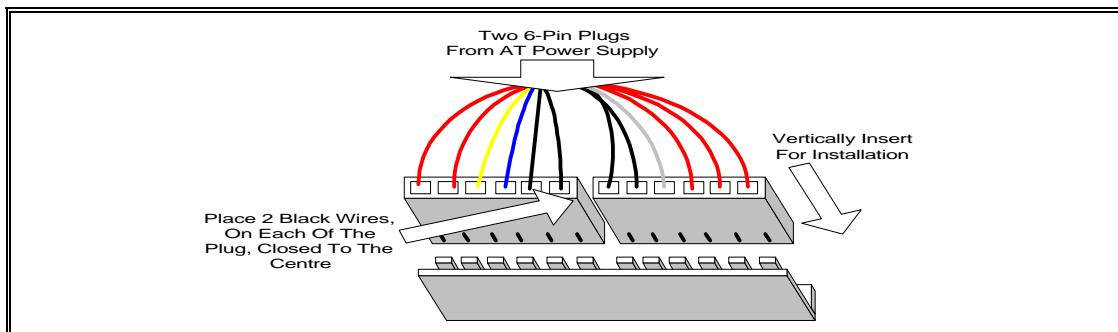

AT Power Connector Installation

ATX Power Connector

A single 20-pin connector incorporates standard $\pm 5V$ and $\pm 12V$, optional 3.3V and soft-power signals. With a power supply supports remote power on/off, the motherboard can turn off the system power through software control, such as the shutdown in Windows 95 Start menu. The system BIOS will turn the system power off when it receives the proper APM command from the OS. APM must be enabled in the system BIOS and OS in order for the soft-off feature to work correctly.

Pin	Signal Name	Pin	Signal Name
1	+3.3V	11	+3.3V
2	+3.3V	12	-12V
3	Ground	13	Ground
4	+5V	14	PW_ON
5	Ground	15	Ground
6	+5V	16	Ground
7	Ground	17	Ground
8	PWRGOOD	18	-5V
9	+5VSB	19	+5V
10	+12V	20	+5V

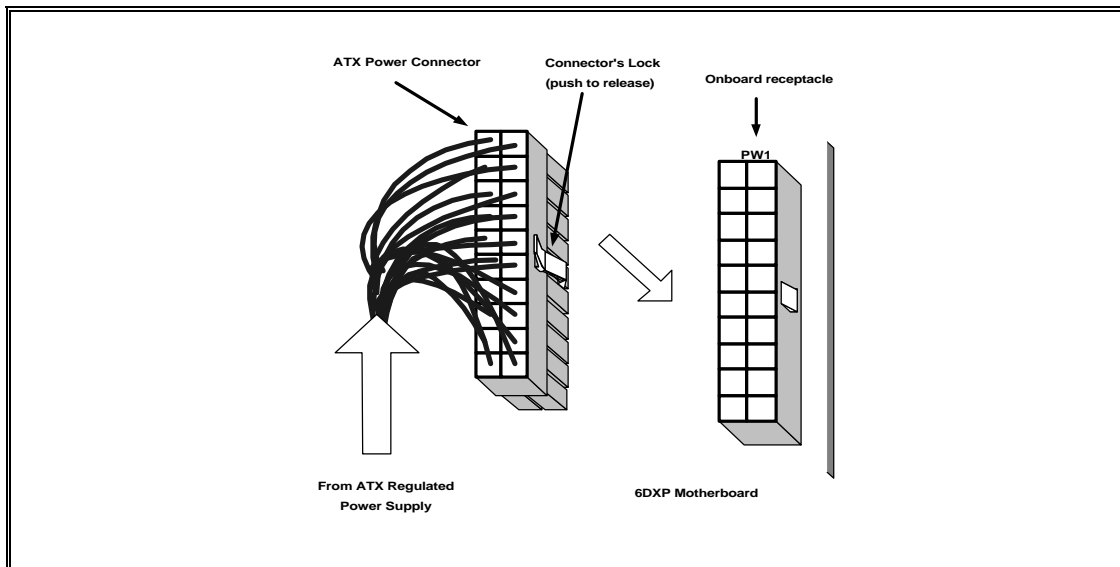

ATX Power Connector Installation

Floppy Drive Connector

This 34-pin connector supports the provided floppy drive ribbon cable. After connecting the single end to the on-board "FLOPPY" connector, connect the remaining plugs on the other end to the floppy drives correspondingly.

IDE Connectors

The two on-board IDE connectors support the provided 40-pin IDE hard disk ribbon cable. After connecting the single end to the board, connect the two remaining plugs at the other end of your hard disk(s). If you install two hard disks, you must configure the two drives by setting its jumpers according to the documentation of your hard disk. Also, you may connect the two hard disks to be both Masters using one ribbon cable on the primary IDE connector and one on the secondary IDE connector.

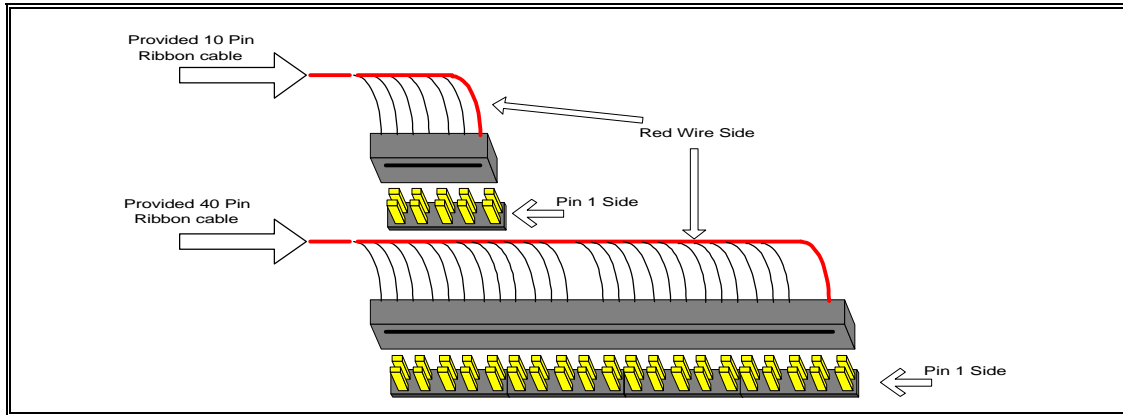

Ribbon cable Installation Example

NOTICE

For the flat ribbon cable connection, please make sure that the pin 1 of the ribbon cable (the red wire side of the cable) is correctly connected to the on-board connector's pin 1 as shown on the "Map of the Motherboard".

Front Panel Function Connectors

All the front panel indicator, speaker, and switch functions are grouped into one on-board 26-pin connector, **JP7**. Front panel features supported include:

- System Reset, RESET
- Power LED, form KEYLOCK
- Hard Drive activity LED, IDE LED
- System Speaker, SPEAKER
- Soft-touch button power on/off, SW ON
- External power saving control, EXTSMI (optional)

The connector pin out are described as the figure below:

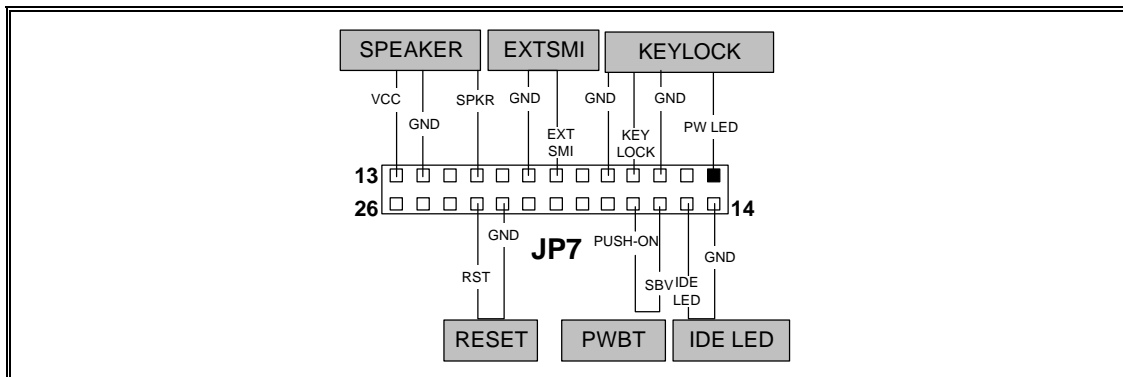

The Onboard Function Connector Pin Out

Integrated USB, Infra-Red and PS/2 Mouse connector

The total of two USB device connectors, a PS/2 mouse, and an Infrared devices are all allocated at this connector (**JP1**).

- Pin1 to Pin5 for USB1 connector
- Pin11 to Pin15 for USB2 connector
- Pin6 to Pin10 for PS/2 connector
- Pin16 to Pin20 InfraRed connector

The connector pin out signal definitions are described as the table below:

Pin	Signal Name	Pin	Signal Name
1 (USB1)	USB +5 Volt	11 (USB2)	USB +5 Volt
2	USB Port 1-	12	USB Port 2-
3	USB Port 1+	13	USB Port 2+
4	Ground	14	Ground
5	No Connect	15	No Connect
6 (PS/2 Mouse)	PS/2 Data	16 (IR)	+5V
7	PS/2 Clock	17	No Connect
8	Ground	18	Infrared Receive
9	No Connect	19	Ground
10	+5V	20	Infrared Transmit

REPLACING BATTERY

A 3V, CR-2030, Lithium battery is installed on the on-board battery socket. This battery is used to supply the CMOS RAM backup power during system powered-off. Danger of explosion if battery is incorrectly replaced. Therefore, if you have any difficulties, please consult to the technical personnel.

Quick Installation Guide

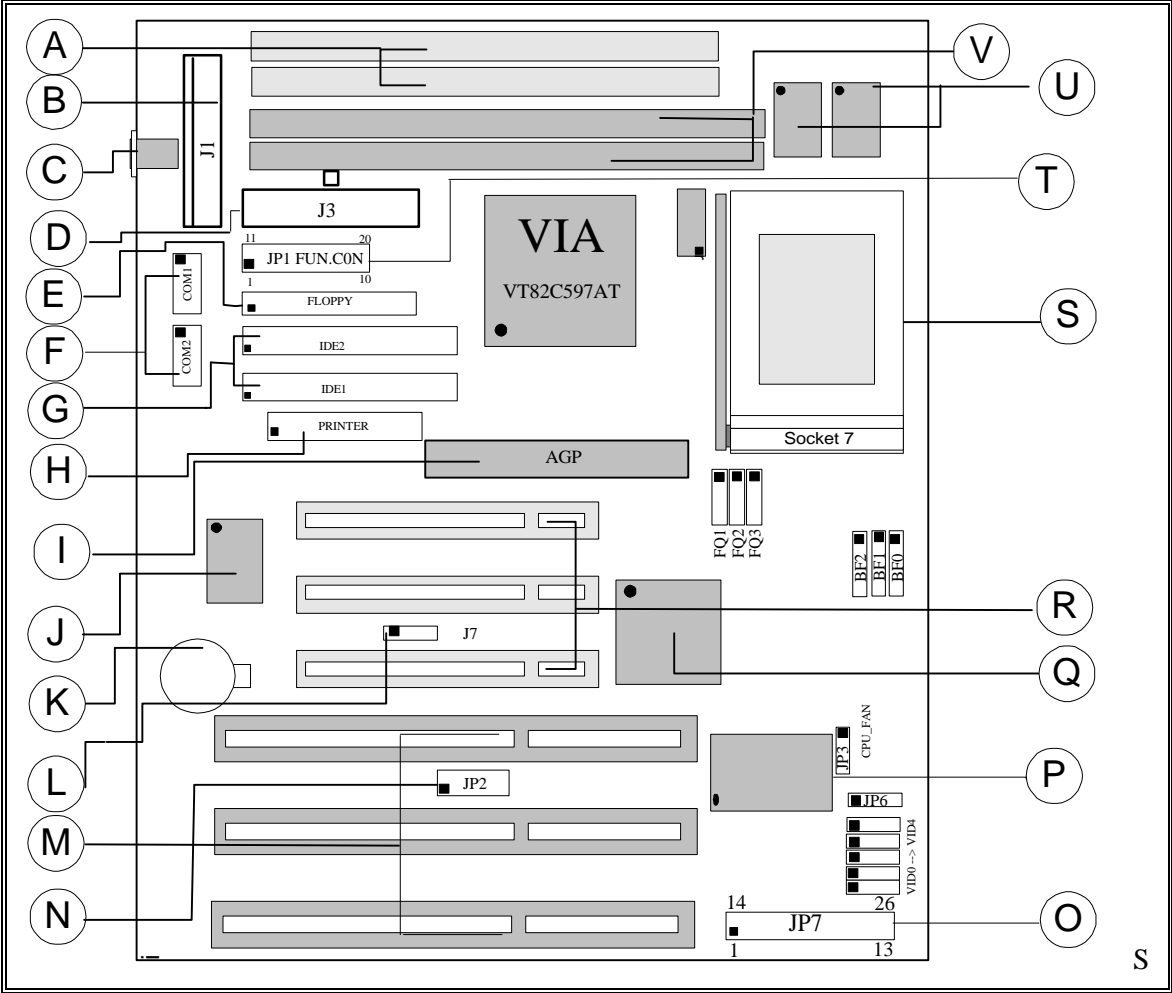

- | | | | |
|---|---------------------------------------|---|--------------------------------|
| A | SIMM RAM Sockets | N | TB-LINK Creative ISA Header |
| B | AT Power Supply Connector | O | Front Panel Connector |
| C | AT Keyboard Connector | P | Flash BIOS EEPROM |
| D | ATX Power Supply Connector | Q | VIA 82C586B System Controller |
| E | Floppy Drive Connector | R | PCI Bus Connectors |
| F | Serial (COM1 and COM2) Headers | S | Pentium Socket 7 |
| G | IDE Connectors Floppy Drive Connector | T | Integrated Functions Connector |
| H | Parallel (Printer) Port Header | U | 512K Cache RAM |
| I | Accelerated Graphic Port (AGP) | V | 3.3V DIMM Sockets |
| J | Integrated I/O Controller | | |
| K | 3V Lithium Battery | | |
| L | WAKEUP-LINK Header | | |
| M | ISA Bus Connectors | | |

“Auto Jumper Yes” Guide

- To enable the “Auto Jumper Yes”, the onboard jumper **JP6** must be shorted to position (1-2). Then, the CPU brands and its core voltage will automatically detected. One thing to remind is that the CPU speed is necessary to be selected at the CMOS setup.
- If **JP6** is shorted to position (2-3), you should follow the jumper table below to setup your CPU settings manually.
- Pressing the key “**F**” during power on clears the CMOS setting, while pressing “**J**” during power on re-detects the CPU type in Auto Jumper Yes mode

“CPU Voltage Selection”

- The voltage regulator will automatically detect and switch between **Single Power Plane** & **Dual Power Planes**.

INTEL PENTIUM P54C/P55C CPU

Internal CPU Speed (MHz)	External Bus Speed (MHz)	FQ1	FQ2	FQ3	Frequency Ratio	BF2	BF1	BF0
90	60	[2-3]	[1-2]	[1-2]	1.5x	1-2	1-2	1-2
100	66	[1-2]	[1-2]	[1-2]	1.5x	1-2	1-2	1-2
120	60	[2-3]	[1-2]	[1-2]	2.0x	1-2	1-2	2-3
133	66	[1-2]	[1-2]	[1-2]	2.0x	1-2	1-2	2-3
150	60	[2-3]	[1-2]	[1-2]	2.5x	1-2	2-3	2-3
166	66	[1-2]	[1-2]	[1-2]	2.5x	1-2	2-3	2-3
200	66	[1-2]	[1-2]	[1-2]	3.0x	1-2	2-3	1-2
233	66	[1-2]	[1-2]	[1-2]	3.5x	1-2	1-2	1-2

CYRIX/IBM 6x86 M1/M2 CPU

P150+	60	[2-3]	[1-2]	[1-2]	2.0x	1-2	1-2	2-3
P166+	66	[1-2]	[1-2]	[1-2]	2.0x	1-2	1-2	2-3
PR200	75	[1-2]	[2-3]	[1-2]	2.0x	1-2	1-2	2-3
PR233	66	[1-2]	[1-2]	[1-2]	3.0x	1-2	2-3	1-2
PR266	66	[1-2]	[1-2]	[1-2]	3.5x	1-2	1-2	1-2

AMD-K5/K6 CPU

PR90	60	[2-3]	[1-2]	[1-2]	1.5x	1-2	1-2	1-2
PR100	66	[1-2]	[1-2]	[1-2]	1.5x	1-2	1-2	1-2
PR133	66	[1-2]	[1-2]	[1-2]	1.5x	1-2	1-2	1-2
PR166/K6-166	66	[1-2]	[1-2]	[1-2]	2.5x	1-2	2-3	2-3
PR200	66	[1-2]	[1-2]	[1-2]	3.0x	1-2	2-3	1-2
PR233	66	[1-2]	[1-2]	[1-2]	3.5x	1-2	1-2	1-2
PR266	66	[1-2]	[1-2]	[1-2]	4.0x	2-3	1-2	2-3

IDT-C6

150	50	[2-3]	[2-3]	[2-3]	3.0x	1-2	2-3	1-2
150	75	[1-2]	[2-3]	[1-2]	2.0x	1-2	1-2	2-3
180	60	[2-3]	[1-2]	[1-2]	3.0x	1-2	2-3	1-2
200	66	[1-2]	[1-2]	[1-2]	3.0x	1-2	2-3	1-2

CPU Voltage Selection

CPU type	Voltage Requirements
Intel Pentium P54C, Cyrix/IBM M1 6x86, AMD-K5, IDT-C6	3.4V (STD) / 3.5V (VRE)
Intel Pentium P55C, Cyrix/IBM M1 6x86L Cyrix/IBM 6x86M2, K6-PR166/200 AMD-K6-PR233, PR266	2.8V 2.9V 2.2V, 2.9V, 3.2V or 3.3V

CPU Core Voltage Table

Vcore	VID0	VID1	VID2	VID3	VID4
2.2V	1-2	2-3	1-2	1-2	1-2
2.8V	1-2	1-2	1-2	2-3	1-2
2.9V	2-3	1-2	1-2	2-3	1-2
3.2V	1-2	1-2	2-3	2-3	1-2
3.3V	2-3	1-2	2-3	2-3	1-2
3.4V	1-2	2-3	2-3	2-3	1-2
3.5V	2-3	2-3	2-3	2-3	1-2

Bus Frequency Ratio

Ratio	BF2	BF1	BF0
2.0x	1-2	1-2	2-3
2.5x	1-2	2-3	2-3
3.0x	1-2	2-3	1-2
3.5x / 1.5x	1-2	1-2	1-2
4.0x	2-3	1-2	2-3
4.5x	2-3	2-3	2-3
5.0x	2-3	2-3	1-2
5.5x	2-3	1-2	1-2

Quick Reference of Your Motherboard

[A] SIMM Sockets

This motherboard provides two 72-pin SIMM sockets. The minimum memory size is 8 MB by using two 1M x 32 SIMM modules and maximum memory size is 128 MB by four 8M x 32 SIMM modules. Memory timing can be configured through the BIOS setup, please refer to the chapter of BIOS setup. They support both Fast Page Mode and Extended Data Output (EDO) SIMM RAM. Both parity and non-parity memory are supported.

NOTICE

Due to the electrical loading characteristics, 64 MB SIMMs using the 16 MB technology are not supported by this motherboard. 64 MB SIMMs using 64 MB technology will be supported by the motherboard when they become available, depending on the characteristics of the memory module.



EDO DRAM

Extended Data Out (or Hyper Page) DRAM is designed to improve the DRAM read performance. EDO DRAM holds the memory data valid until the next memory access cycle, unlike standard fast page mode DRAM that tri-states the memory data when the pre-charge cycle occurs, prior to the next memory access cycle. EDO DRAM timings are X-2-2-2 compared to FPM timings of X-3-3-3

[B] AT Power Supply Connector

Based on the AT specification, one 12-pin power connector covers all the required power sources, $\pm 5V$ and $\pm 12V$.

[C] AT Keyboard Connector

This connection is used for a standard IBM-compatible keyboard, such as 101 enhanced keyboard.

[D] ATX Power Supply Connector

Based on the ATX specifications, one 20-pin power connector covers all the required power sources, $\pm 5V$, $\pm 12V$, and $\pm 3.3V$, with soft-touch button power on/off features. This connector reduces the installation time and minimizes the chance of defects caused by incorrect connection.

[E] Floppy Drive Connector

A 34-pin connector on-board allows connection to two 360K, 720K, 1.2M, 1.44, 2.88M floppy disk drives.

[F] Serial (COM 1 and COM2) Port Headers

This motherboard provides two high-speed UART compatible serial ports.

[G] IDE Connectors

This motherboard have two independent high performance bus-mastering PCI IDE interfaces capable of supporting up to UltraDMA-33 devices. The system BIOS supports automatic detection of the IDE device data transfer rate and translation between different kinds of device mode such as Logical Block Addressing (LBA) and Extended Cylinder Sector Head (ECSH) translation modes and ATAPI (e.g., CD-ROM) devices on both IDE interfaces.

In a true multi-tasking operating systems like Windows® 95 and Windows® NT, the IDE interface can operate as a PCI bus master capable of supporting Ultra DMA-33 devices with transfer rates of up to 33MB/sec.

[H] Parallel (Printer) Port Connector

One Parallel port with SPP, EPP and ECP capabilities.

[I] Accelerated Graphic Port (AGP)

The AGP is compatible with the Accelerated Graphics Port specification. The AGP offers a much higher throughput over the PCI bus does. PCI currently only supports 33Mhz can transport 133MB/s at peak rates over its 32bit data bus. AGP is clocked with 66Mhz, which enables a peak rate of 266 MB/s at the classic so called 'X1' mode. If using the 'X2' mode, it can transport up to 532MB/s at peak rate.

[J] Integrated I/O Controller

On the motherboard, keyboard controller, real time clock, serial ports, parallel port and floppy drive are all integrated into a single chip. The I/O port allows you to configure through the BIOS setup. This integrated I/O chip provides:

- Plug-and-Play compatible.
- Supports two 360K, 720K, 1.2M, 1.44, 2.88M floppy disk drives
- One multi-mode high performance parallel port which can be configured in BIOS as standard (SPP) mode, enhanced (EPP) mode, high speed (ECP) mode.
- Supports two 16C550 compatible enhanced serial ports.
- Supports IrDA or ASKIR infra-red interface.

[K] 3V Lithium Battery

An on-board battery holder is used to hold a 3 Volts CR-2032 Lithium battery which makes the battery's replacement more convenient. This battery is used to supply power for the RTC CMOS RAM in order to save your system setting and date/time counting during system power-off. In general, the battery's life-time is about 2-3 years. If you see a "BIOS checksum error" message happened while system turn-on, it may be caused by the battery low. You can try to fix it by simply replaced the battery. The scrapped Lithium battery should be handled with care and should not be thrown into fire.

[L] WAKEUP-LINK Interface

This header is used to connect an add-in NIC (Network Interface Card) which has WOL capability to a motherboard.

[M] ISA Add-in Board Connectors

This motherboard provides three 16-bits ISA slot which allows backward hardware compatibility.

[N] TB-LINK Interface

This header interface supporting TOMATO™ SCV6 Sound Card using Creative Audio Chip.

[O] Front Panel Function Connector

For your convenience, all the front panel functions are integrated into a single connector, which included power LED and keyboard lock, turbo switch, reset switch, SMI switch and speaker.

[P] Flash BIOS

The flash BIOS allows user have more flexibility to upgrade their motherboard. The flash BIOS can be programmed by software easily. For the latest BIOS upgrade information, please feel free to visit our web site: <http://www.zida.com>.

[Q] 82C586 PCI/ISA Bridge

The VIA 82C586 is a 208-pin QFP package IC which provides the following features:

- Interface between the PCI local bus and ISA bus.
- Supports for 2 Universal Serial Bus (USB) ports.
- Integrated fast IDE interface supports up to 4 devices. With separated Master/Slave mode support, it provides data transfer rate up to 33 MB/sec in UltraDMA-33 mode. It is also backward compatible to Mode 4 device. In addition, it also integrated sixteen levels of prefetch and write buffers and full scatter and gather capability which further enhanced the system performance.
- Enhanced DMA controller with Fast Type-F DMA
- Counters/Timers provides advanced power management with programmable system management interrupt (SMI).

[R] PCI Add-in Board Connectors

This motherboard provides three full-length 32-bits PCI slots with up to 133MB/sec burst data transfer rate.

[S] Pentium® Type-7 Socket

The type-7 socket is a 321-pins, zero insertion force (ZIF) socket. It provides users with a performance upgrade path to Pentium® OverDrive technology.



PENTIUM® PROCESSOR

An approved Pentium heatsink is necessary for proper thermal dissipation in an AT compliant chassis. The processor/heatsink assembly must be securely fastened to the Socket 7 ZIF socket by two clips. These clips fit over the heatsink assembly and attach to the outer wide tabs of the Socket 7 assembly.

[T] Integrated Functions Connector

I) From Pin1 to Pin5 is the first USB device “USB1” and Pin11 to Pin15 is the second USB device “USB2” connector. Universal Serial Bus (USB) is new interface standard for any I/O device “Outside the Box”. USB makes your peripherals have a real plug and play (PnP) capabilities with up to 12MB/sec data speed In the coming soon, any external device connected to your computer will be standardized into USB standard which are all have a special 4-pin rectangle shape connector. Therefore, with the Intel chipset, this motherboard builds two USB headers on-board for you future investment. If you are using a USB device, you must purchase an optional USB connector.

- II) From Pin6-10 is the PS/2 device, likes some PS/2 keyboard and mouse, are all have a standard 6-pin round shape connector. However, it does not have a unique onboard standard. Therefore, please refer to the Chapter “Motherboard Installation” , in order to purchase an suitable PS/2 Mouse Connector.
- III) From Pin16-20 is a 5-pin interface on the front panel I/O connector is provided to allow connection to a Hewlett Packard HSDSL-1000 compatible Infra-red (IrDA) transmitter/receiver. Once the module is connected to the front panel I/O header, Serial port 2 can be re-directed to the IrDA module. When configured for IrDA, the user can transfer files to or from portable devices such as laptops, PDA’s and printers using application software such as LapLink. The IrDA specification provides for data transfers at 115kbps from a distance of 1 meter. Support for Consumer Infra Red (ASK-IR) is also included, please refer to your IR equipment for more detailed information.

[U] 512K Cache RAM

256K/512K Cache RAM on-board in order to further enhanced of your system performance.

[V] SDRAM Socket

There are two unbuffered, 3.3 Volts, SDRAM socket on-board provides more flexibility for your system memory upgrade.

Motherboard Technical Specification

ENVIRONMENT

Parameter	Specification
Operating	
Temperature	+0°C to +55°C
Humidity	20% to 80%
Atmosphere	Non-condensing
Non-operating/Transportation	
Temperature	-20°C to +65°C
Humidity	10% to 90%
Atmosphere	Non-condensing
TX Power Supply Requirement	
±5 V	±5 %
±12 V	±5 %
Vibration	
Operating	0.2G Z axis (up and down), 5 to 300 Hz 0.1G X axis (front and rear), 5 to 300 Hz Y axis (left and right), 5 to 300 Hz

DIMENSIONS AND WEIGHT

Dimension Approx.	220 x 224 mm (8.5 x 8 inches)
Net Weight	0.46 Kg (1.05 lb.)

ELECTRICAL SPECIFICATION

Onboard Voltage Regulation	Under 3.3V condition
Voltage transient	± 5%
Set point variation	± 1%
Onboard Current Limitation	
Under 3.3V condition	about 14 Ampere (max.)

POWER CONSUMPTION

The board is designed to operate with 140-200 W AT power supply. For a system configured with the motherboard including a 200 MHz Pentium processor w/ 256 KB Cache, 64 MB EDO DRAM, 3.5-inch floppy drive, 2.1 GB IDE hard drive, 8X IDE CD-ROM, and a PCI graphics card, The overall calculated power dissipation is about 80W. However, this information is provided only as reference for the total system power usage.

Request For Technical Support

In order to provide you with effective and quick technical support, we need to know your system specification and environments. Please fill the following form as complete as possible so we can give you assistance.

PRODUCT INFORMATION	
MODEL	
CHIPSET MODEL	
RAM TYPE/SIZE/BRAND/SPEED	
BIOS VERSION	
PURCHASE DATE	
PROBLEM DESCRIPTION	
OPERATING SYSTEM	
APPLICATION SOFTWARE	
PROBLEM DESCRIPTION	

SYSTEM CONFIGURATION		
Display Card (Brand/Model)		
Resolution		
IDE Controller Card (Brand/Model)		
LAN Card (Brand/Model)		
Fax/Modem Card (Brand/Model)		
SCSI Controller (Brand/Model)		
Multi I/O Card (Brand/Model)		
Other Add-on Card (Brand/Model)		
IDE Disk Drive	PRIMARY MASTER (Brand/Model)	
	PRIMARY SLAVE (Brand/Model)	
	SECONDARY MASTER (Brand/Model)	
Floppy Drive	SECONDARY SLAVE (Brand/Model)	
	DRIVE A (Brand/Model)	
	DRIVE B (Brand/Model)	
Other Device (Brand/Model)		