

P2XBL

Rev. B+ System Board User's Manual

Copyright

This publication contains information that is protected by copyright. No part of it may be reproduced in any form or by any means or used to make any transformation/adaptation without the prior written permission from the copyright holders.

This publication is provided for informational purposes only. The manufacturer makes no representations or warranties with respect to the contents or use of this manual and specifically disclaims any express or implied warranties of merchantability or fitness for any particular purpose. The user will assume the entire risk of the use or the results of the use of this document. Further, the manufacturer reserves the right to revise this publication and make changes to its contents at any time, without obligation to notify any person or entity of such revisions or changes.

© 1998. All Rights Reserved.

Trademarks

Microsoft® MS-DOS®, Windows™ and Windows® 95 are registered trademarks of Microsoft Corporation. Intel and Pentium are registered trademarks of Intel Corporation. Cyrix, 6x86, 6x86L and 6x86MX are registered trademarks of Cyrix Corporation. AMD, K5 and K6 are registered trademarks of Advanced Micro Devices, Inc. IBM is a registered trademark of International Business Machine Corporation. Award is a registered trademark of Award Software, Inc. Other trademarks and registered trademarks of products appearing in this manual are the properties of their respective holders.

Caution:

Danger of explosion if battery incorrectly replaced.

Replace only with the same or equivalent type recommended by the manufacturer.

Dispose of used batteries according to the battery manufacturer's instructions.

FCC and DOC Statement on Class B

This equipment has been tested and found to comply with the limits for a Class B digital device, pursuant to Part 15 of the FCC rules. These limits are designed to provide reasonable protection against harmful interference when the equipment is operated in a residential installation. This equipment generates, uses and can radiate radio frequency energy and, if not installed and used in accordance with the instruction manual, may cause harmful interference to radio communications. However, there is no guarantee that interference will not occur in a particular installation. If this equipment does cause harmful interference to radio or television reception, which can be determined by turning the equipment off and on, the user is encouraged to try to correct the interference by one or more of the following measures:

- Reorient or relocate the receiving antenna.
- Increase the separation between the equipment and the receiver.
- Connect the equipment into an outlet on a circuit different from that to which the receiver is connected.
- Consult the dealer or an experienced radio TV technician for help.

Notice:

1. The changes or modifications not expressly approved by the party responsible for compliance could void the user's authority to operate the equipment.
2. Shielded interface cables must be used in order to comply with the emission limits.

Table of Contents

Chapter 1 - Introduction

1.1 Features and Specifications	6
1.2 Package Checklist	12

Chapter 2 - Hardware Installation

2.1 System Board Layout	13
2.2 Installation Steps	14
2.2.1 Installing System Memory	14
2.2.2 Installing a Processor	16
2.2.3 Jumper Settings for CPU Front Side Bus	26
2.2.4 Jumper Settings for CMOS Clear	27
2.2.5 Jumper settings for Wake-On-Keyboard/Mouse	28
2.2.6 Installing Expansion Cards	29
2.2.7 Connecting the Ribbon Cables and Wires of the Ports and Connectors	31
2.2.8 Installing the System Board	43

Chapter 3 - Award BIOS Setup Utility

3.1 The Basic Input/Output System	44
3.1.1 Standard CMOS Setup	44
3.1.2 BIOS Features Setup	48
3.1.3 Chipset Features Setup	52
3.1.4 Power Management Setup	56
3.1.5 PNP/PCI Configuration	60
3.1.6 Load Fail-Safe Settings	62
3.1.7 Load Optimal Settings	62
3.1.8 Integrated Peripherals	63
3.1.9 Supervisor Password	67
3.1.10 User Password	68
3.1.11 IDE HDD Auto Detection	68
3.1.12 Save & Exit Setup	69
3.1.13 Exit Without Saving	69

Chapter 4 - Supported Softwares

4.1 Desktop Management Interface	70
4.2 System Health Monitor Utility.....	73
4.3 Drivers	74

Appendix A - System Error Messages

A.1 POST Beep	75
A.2 Error Messages	75

Appendix B - Troubleshooting

B.1 Troubleshooting Checklist	77
-------------------------------------	----

Chapter 1 - Introduction

1.1 Features and Specifications

1.1.1 Features

Chipset

- Intel® 440BX AGPset

Processor

The system board is equipped with a 242-pin Intel® Slot 1 processor slot for installing an Intel Pentium® II processor that is packaged in an SEC (Single Edge Contact) cartridge or an Intel Celeron™ processor:

- 233/66MHz, 266/66MHz, 300/66MHz, 300/100MHz, 333/66MHz, 350/100MHz, 400/100MHz or 450/100MHz Pentium® II processor with 512KB L2 cache
- 266/66MHz, 300/66MHz, 300A/66MHz or 333/66MHz or Intel Celeron™ processor

System Memory

The system board supports 8MB to 384MB memory. It is equipped with three 168-pin DIMM sockets using x64/x72 unbuffered PC SDRAM, 3.3V. The PC SDRAMs supported are PC-66 SDRAM for 66MHz FSB and PC-100 SDRAM for 100MHz FSB. The system board also supports EC and ECC (uses x72 PC SDRAM).

Expansion Slots

The system board is equipped with 1 dedicated AGP slot, 3 dedicated PCI slots, 2 dedicated 16-bit ISA slots and 1 shared PCI/ISA slot. All PCI and ISA slots are bus masters.

Desktop Management Interface (DMI)

The system board comes with a DMI 2.0 built into the BIOS. The DMI utility in the BIOS automatically records various information

about your system configuration and stores this information in the DMI pool, which is a part of the system board's Plug and Play BIOS. DMI, along with the appropriately networked software, is designed to make inventory, maintenance and troubleshooting of computer systems easier. Refer to Chapter 4 for instructions on using the DMI utility.

Onboard I/O

- Two NS16C550A-compatible DB-9 serial ports
- One SPP/ECP/EPP DB-25 parallel port
- One floppy drive interface supports up to two 2.88MB floppy drives
- One mini-DIN-6 PS/2 mouse port
- One mini-DIN-6 PS/2 keyboard port
- One WOL (Wake-On-LAN) connector

PCI Bus Master IDE Controller

- Two PCI IDE interfaces support up to four IDE devices
- Ultra DMA/33 supported (Synchronous Ultra DMA mode - data transfer rate up to a maximum of 33MB/sec.)
- PIO Mode 3 and Mode 4 Enhanced IDE (data transfer rate up to 16.6MB/sec.)
- Bus mastering reduces CPU utilization during disk transfer
- ATAPI CD-ROM supported
- LS-120 and ZIP supported

IrDA Interface

The system board is equipped with an IrDA connector for wireless connectivity between your computer and peripheral devices. It supports peripheral devices that meet the IrDA or ASKIR standard.

USB Ports

The system board is equipped with two USB ports. USB allows data exchange between your computer and a wide range of simultaneously accessible external Plug and Play peripherals.

BIOS

- Award BIOS, Windows® 95 Plug and Play compatible
- Flash EPROM for easy BIOS upgrades

Power Supply Connector

The system board is equipped with an ATX power supply connector. Using an ATX power supply, you can either shut down your computer by pressing the Power button located on the front bezel of your computer or by executing the Shut Down command under the Windows® 95 operating system. Your system will then enter the “Soft Off” state.

To power-on your system automatically, enable “Resume By Alarm” in the Power Management Setup of the Award BIOS. This will allow you to set the date and time you would like your system to power-on.

1.1.2 Technology

AGP (Accelerated Graphics Port)

The system board is equipped with 1 AGP slot. AGP is an interface designed to support high performance 3D graphics cards. It utilizes a dedicated pipeline to access system memory for texturing, z-buffering and alpha blending; delivering up to 533MB/sec. bandwidth for 3D graphics applications. AGP in this Pentium® II processor based system board will deliver faster and better graphics with your PC.

PC SDRAM (Synchronous Dynamic Random Access Memory)

PC SDRAM uses a fast memory interface technology to meet the memory bandwidth requirements of Intel processors and chipset. This technology includes using the clock on the chip to synchronize with the CPU clock so that the timing of the memory chips and the timing of the CPU are synchronized. Please refer to Intel's web site for more information on PC SDRAM.

Creative SB-LINK™

The system board is equipped with a Creative SB-LINK™ connector. SB-LINK™ serves as a bridge between the system board and a Creative PCI sound card to deliver Sound Blaster® AWE64D performance. Refer to “SB-LINK™ Connector” in Chapter 2 for more information.

Ultra DMA/33 Bus Master IDE

Synchronous Ultra DMA mode provides data transfer rate up to a maximum of 33MB/sec, which is twice the data transfer rate of Enhanced IDE or ATA-2. This enables the CPU to operate more efficiently when handling simultaneous events.

ECC (Error Checking and Correction)

ECC is a function that allows the system to recover from memory failure. It detects single-bit and multiple-bit errors and corrects single-bit error thus providing uninterrupted processing of data. To use this function, you must install DIMM that supports parity. Refer to “Installing System Memory” in Chapter 2 of this manual.

ACPI (Advanced Configuration and Power Interface)

The system board is designed to meet the ACPI specification. ACPI has energy saving features that enables PCs to implement Power Management and Plug-and-Play with operating systems that support OS Direct Power Management.

PC '97 Compliant

The system board is PC '97 compliant. This will optimize your PC system to run Windows® 95 and Windows NT® and future versions of these operating systems.

1.1.3 Intelligence

Monitors Processor Temperature and Overheat Alarm

The system board is able to detect the temperature of the processor. An alarm will sound in case of processor overheat. Refer to Chipset Features Setup (Chapter 3) and System Health Monitor Utility (Chapter 4).

Monitors Processor/Chassis Fan Speed and Failure Alarm

The system board is able to detect the fan speed (RPM-Revolution Per Minute) and alerts you to attend to any irregularity that may damage your system. Refer to Chipset Features Setup (Chapter 3) and System Health Monitor Utility (Chapter 4).

Monitors Power Voltages and Failure Alarm

The system board is able to detect the output voltage of the power supply. An alarm will sound warning you of voltage irregularity. Refer to Chipset Features Setup (Chapter 3) and System Health Monitor Utility (Chapter 4).

Automatic Fan Control

With the system's power switched on, the processor's fan will rotate only if the temperature of the processor is over 25°C. This saves energy, prevents system overheat, prolongs fan life and implements a silent system.

Dual Function Power Button

Depending on the setting in the BIOS setup, this switch will allow your system to enter the Soft-Off or Suspend mode. "Soft-Off By PWR-BTTN" in the Power Management Setup (Chapter 3) allows you to select the method of powering off your system.

External Modem Wake-up/Ring-on

The Modem Wake-Up feature allows the sleeping (Suspend mode) PC to wake-up to respond to incoming calls. The Modem Ring-on feature allows the Soft Power Down (Soft-Off) PC to power-on to respond to incoming calls. Enable this function in the “Resume By Ring” field of the Power Management Setup (Chapter 3).



Note:

This feature supports external modem only.

RTC Timer to Power-On the System

The RTC installed on the system board allows your system to automatically power-on on the set date and time. Set the date and time you would like your system to power-on in the “Resume By Alarm” field of the Power Management Setup (Chapter 3).

Wake-On-LAN Ready

The Wake-On-LAN function allows the network to wake up a Soft Power Down (Soft-Off) PC. To use the Wake-On-LAN function, make sure your LAN card also support this function. Refer to the “Wake-On-LAN Connector” section (Chapter 2) and “Resume By LAN” field in the Power Management Setup (Chapter 3).



Important:

The 5VSB power source of your power supply must support $\geq 720\text{mA}$ (minimum).

Wake-On-Keyboard/Wake-On-Mouse

This function allows you to use the keyboard or mouse to power-on the system. Refer to “Jumper Settings for Wake-On-Keyboard/Wake-On-Mouse” in Chapter 2 and “Keyboard/Mouse Power On” in the Integrated Peripherals setup of the Award BIOS in Chapter 3 for more information.



Important:

The power button will not function once a keyboard password has been set in the “KB Power On Password” field of the Integrated Peripherals setup. To power-on the system, you must type the password then press <Enter>.

Virus Protection

Most viruses today destroy data stored in hard drives. The system board is designed to protect the boot sector and partition table of your hard disk drive. If an attempt is made to write to the boot sector or partition table of the hard disk drive, the BIOS will halt the system and an error message will appear. Refer to the “Virus Warning” field in the BIOS Features Setup (Chapter 3).

I.2 Package Checklist

The system board package contains the following items:

- The system board
- A user’s manual
- One 40-pin IDE hard disk cable
- One 34-pin floppy disk drive cable
- One CD

If any of these items are missing or damaged, please contact your dealer or sales representative for assistance.

Chapter 2 - Hardware Installation

2.1 System Board Layout

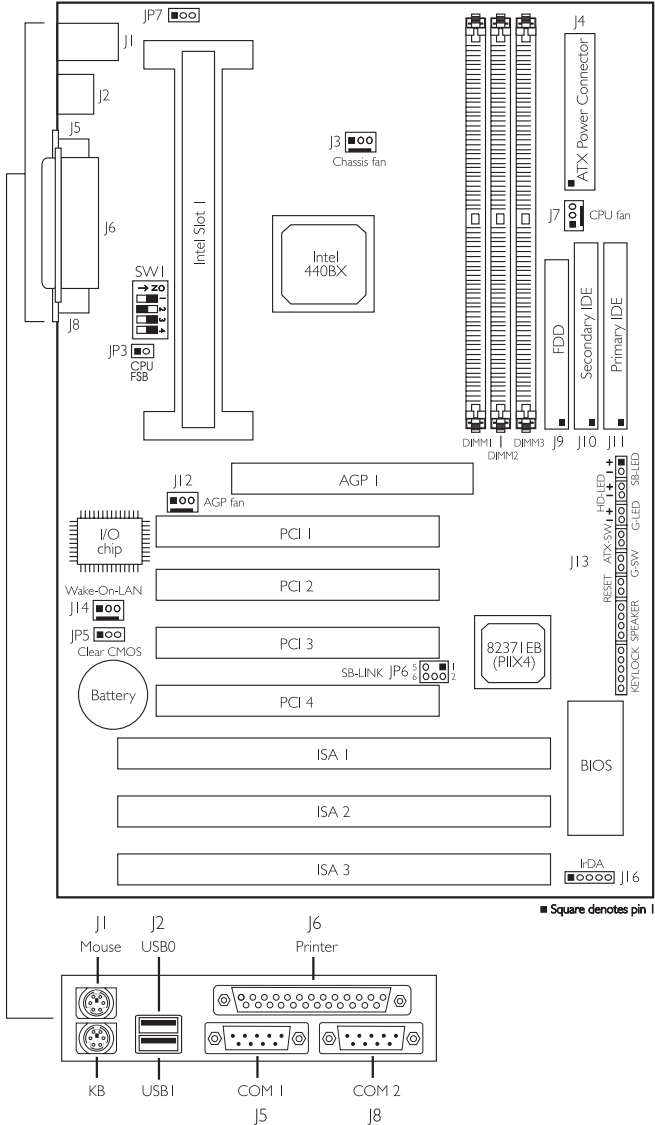

2.2 Installation Steps

**Warning:**

Electrostatic discharge (ESD) can damage your system board, processor, disk drives, add-in boards, and other components. Perform the upgrade instruction procedures described at an ESD workstation only. If such a station is not available, you can provide some ESD protection by wearing an antistatic wrist strap and attaching it to a metal part of the system chassis. If a wrist strap is unavailable, establish and maintain contact with the system chassis throughout any procedures requiring ESD protection.

The following outlines the basic installation steps prior to installing the system board into the chassis.

- 2.2.1 Install the System Memory
- 2.2.2 Install the Processor
- 2.2.3 Set the Jumpers on the System Board
- 2.2.4 Install the Expansion Cards
- 2.2.5 Connect the Ribbon Cables and Wires of the Ports and Connectors
- 2.2.6 Install the System Board

2.2.1 Installing System Memory

The system board is equipped with three 168-pin DIMM (Dual In-line Memory Module) sockets. It supports 8MB to 384MB memory using x64/x72 unbuffered PC SDRAM, 3.3V (PC-66 SDRAM for 66MHz FSB or PC-100 SDRAM for 100MHz FSB).

The system board supports the Error Checking and Correction (ECC) function. To use this function,

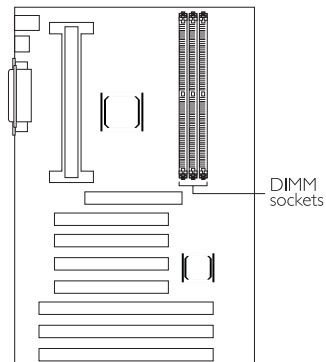

you must install DIMM that supports parity. That is, DIMM that typically has 9 memory chips per side. This kind of module has 8 standard memory chips and a parity chip. DIMM with no parity has 8 standard memory chips only.

The table below shows the supported DIM modules and their corresponding memory sizes. You may install DIMM in any DIMM sockets. Memory size and speed can vary between sockets. The BIOS will automatically detect the memory type, size and speed.

DIMMs	Memory Size
1MBx64/x72	8MB
2MBx64/x72	16MB
4MBx64/x72	32MB
8MBx64/x72	64MB
16MBx64/x72	128MB

Installing the DIM Module

A DIM module simply snaps into a socket on the system board. Pin 1 of the DIM module must correspond with Pin 1 of the socket.

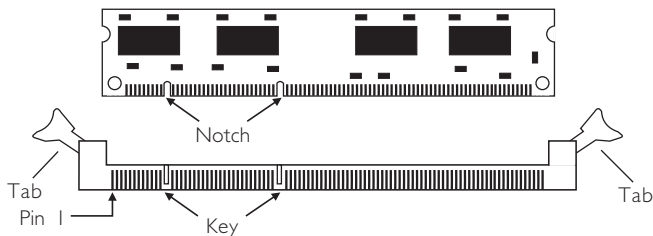

1. Pull the "tabs" which are at the ends of the socket to the side.
2. Position the DIMM above the socket with the "notches" in the module aligned with the "keys" on the socket.
3. Seat the module vertically into the socket. Make sure it is completely seated. The tabs will hold the DIMM in place.

2.2.2 Installing a Processor

The system board is equipped with a 242-pin processor slot for installing an Intel Pentium® II processor that is packaged in an SEC (Single Edge Contact) cartridge.



Warning:

The processor must be kept cool by using a fan with heatsink. Leave certain space clearances to maintain proper airflow once the processor and heatsink are installed. All cables (for floppy drive, hard drive, CD-ROM, etc.) must be routed clear of the processor and its airspace. Otherwise, the processor will overheat and damage the processor and the system board.

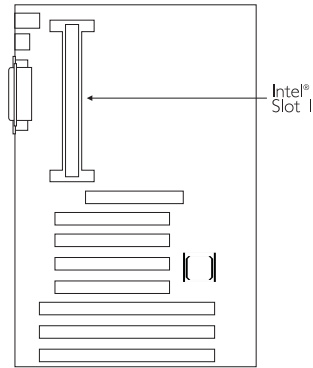

2.2.2.1 Installing the Retention Mechanism

The system board comes with an easy-to-install Retention Mechanism package. The Retention Mechanism is used to hold an Intel Pentium® II processor to the processor slot. Make sure the system board is on a workbench (not in the chassis). To install the Retention Mechanism, follow the steps below.

1. Unpack the Retention Mechanism package.

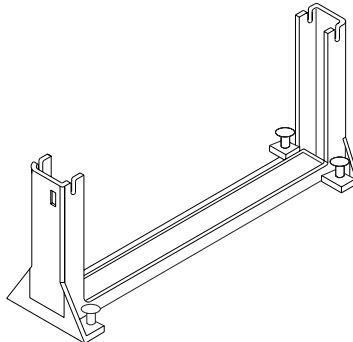

2. Hold the Retention Mechanism upright and position it above the processor slot.
3. Now slide the Retention Mechanism downward so that it fits over the processor slot. Firmly press the ends of the Retention Mechanism until it snaps into place. The Retention Mechanism will only fit in one direction. It has a keying mechanism so that the notch on one of the inner side of the Retention Mechanism will fit into the key on one side of the processor slot.

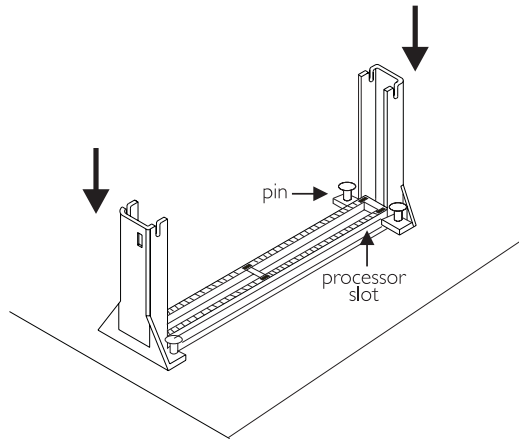

4. Firmly press the "pins" located at the 4 corners of the Retention Mechanism to as far as it will go. These pins will stabilize the Retention Mechanism onto the system board.

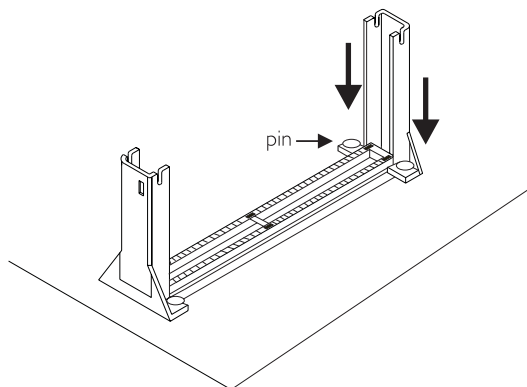

2.2.2.2 Installing Boxed Processor

1. Mount the two black plastic pegs onto the system board. These pegs will be used to attach the fan heatsink supports. Notice that one hole and the base of one peg are larger than the other hole and peg base. Push each peg into its hole firmly until you hear it “click” into place.

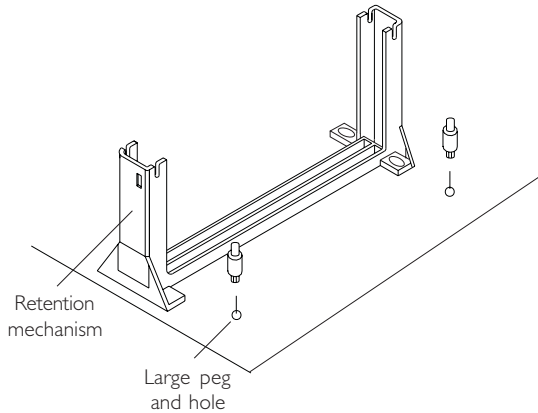

2. Slide a black plastic heatsink support onto each end of the fan heatsink, making sure that the hole and clip are on the outside edge of the support. (If the supports are reversed, the holes will not line up with the pegs on the system board). Slide each heatsink support toward the center of the processor until the support is seated in the outside groove in the fan housing.

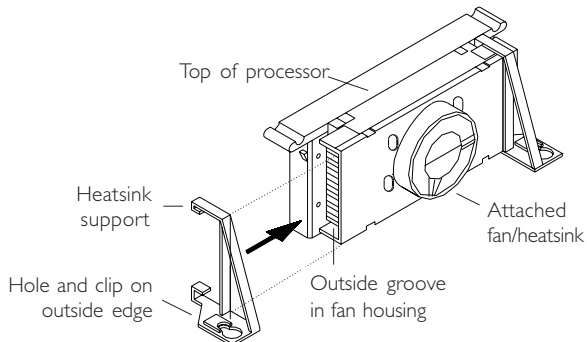

- Slide the clip (A) on each support toward the processor; exposing the hole that will fit over the peg on the system board. Push the latches (B) on the processor toward the center of the processor until they click into place.
- Hold the processor so that the fan shroud is facing toward the pegs on the system board. Slide the processor (C) into the Retention Mechanism and slide the supports onto the pegs. Ensure that the pegs on the system board slide into the holes in the heatsink support and that the alignment notch in the processor fits over the plug in the processor slot. Push the processor down firmly, with even pressure on both sides of the top, until it is seated.

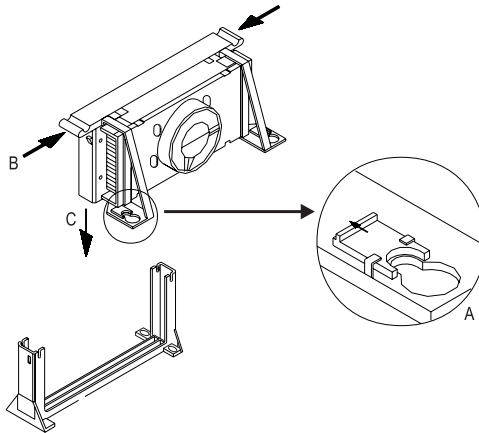

- Slide the clips on the supports (A) forward until they click into place to hold the pegs securely. (Apply slight pressure on the peg and push the peg toward the clip while pushing the clip forward.) Push the latches on the processor (B) outward until they click into place in the Retention Mechanism. The latches must be secured for proper electrical connection of the processor.
- Attach the small end of the power cable (C) to the three-pin connector in the processor; then attach the large end to the three-pin connector (J7 - fan connector) on the system board.

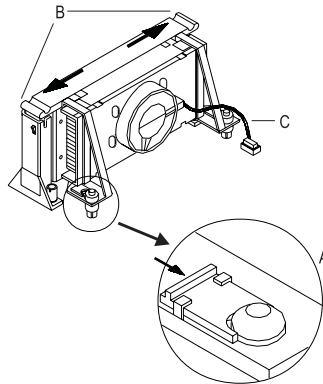

Removing the Processor

To remove the processor from the system board, follow these steps (the reverse of the installation process).

1. Disconnect the fan power cable from the system board. (We recommend that you leave the cable connected to the processor).
2. Slide the clips on the supports backward to release the pegs in the system board. Push the latches on the processor toward the center of the processor until they click into place.
3. Lift one end of the processor until it is freed from the processor slot. Lift the other end of the processor until it is freed from the processor slot. Lift the entire processor (with the fan heatsink supports attached) until it is free from the Retention Mechanism.
4. Remove the heatsink support pegs from the system board and discard them. With one hand, squeeze together the two halves of the peg on the bottom side of the system board. With the other hand, pull the peg out of the hole in the system board. **Do not** reuse the pegs.



Caution:

When handling the processor, avoid placing direct pressure on the label area of the fan. When removing the processor, avoid pressing down on the system board or components. Instead, press down on plastic connectors.

2.2.2.3 Installing OEM Processor

If you are using Intel Pentium® II processor in OEM package, please follow the steps below.

1. Your OEM package may include the following items.

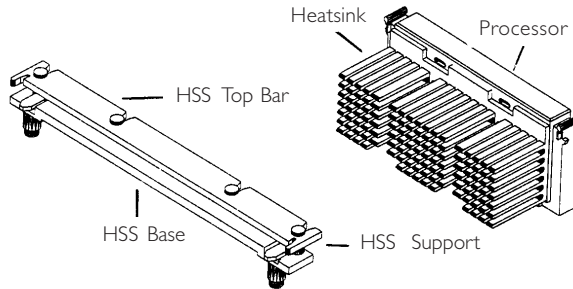

Important:

- *Make sure your heatsink is attached with a fan to prevent overheating the processor.*
- *Contact your heatsink manufacturer to check whether your processor requires a Heatsink Support (HSS) installed on the system board.*

2. Push the HSS Top Bar sideways to free the HSS Top Bar from the retaining "tabs" of the HSS Base.

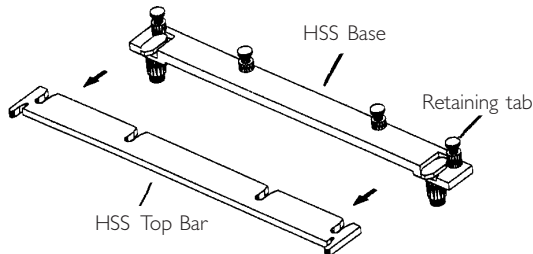

3. Remove the HSS Pins located on each end of the HSS Base.

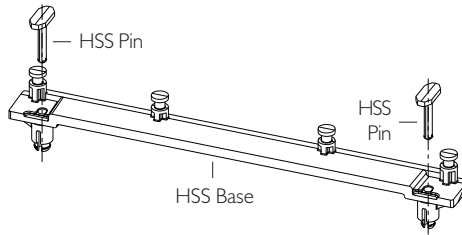

4. Install the HSS Base by pushing each side down firmly into the holes on the system board. (The HSS Base can only be installed in one direction). Make sure it locks into place.
5. Replace the HSS Pins on each end of the HSS Base. These pins will insert through the HSS Base to secure it to the system board.
6. Hold the processor and push the latches toward the center of the processor until they click into place.

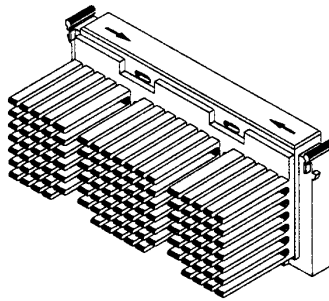

7. Hold the processor so that the heatsink is facing toward the HSS Base on the system board. Slide the processor into the Retention Mechanism. Ensure that the alignment notch in the processor fits into the plug in the processor slot. Push the processor down firmly, with even pressure on both sides of the top, until it is seated.

8. Push the latches on the processor outward until they click into place in the Retention Mechanism. The latches must be secured for proper electrical connection of the processor.

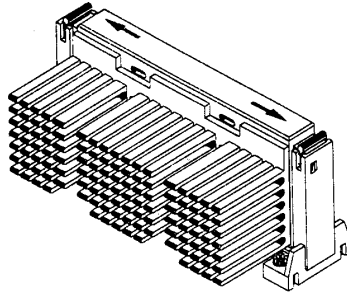

9. Slide the HSS Top Bar into the heatsink until it locks into place.

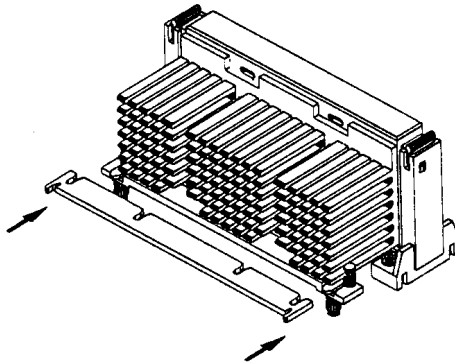





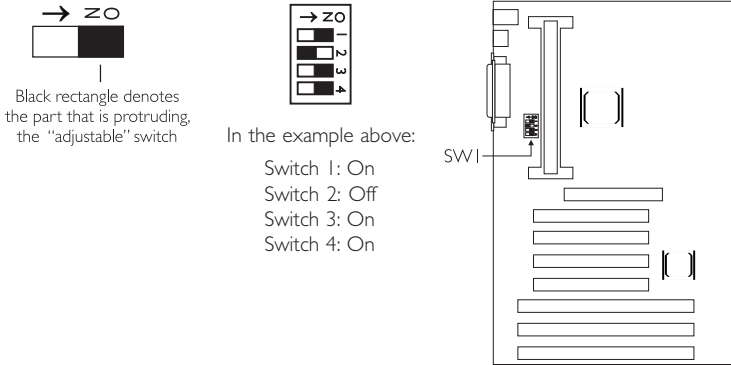

10. Attach the small end of the power cable (C) to the three-pin connector in the processor; then attach the large end to the three-pin connector (J7 - fan connector) on the system board.

2.2.2.4 DIP Switch Settings of the Processors

The table below shows the supported processors and their corresponding DIP switch settings (SW1). There are 4 switches on SW1. The black rectangle in the diagram denotes the part that is protruding, the “adjustable” switch. Make sure SW1 is set correctly before applying power; otherwise you will not be able to power-on the system.



Processor		Frequency Ratio	SW1
66MHz	100MHz		
-----	300MHz	3x	
233MHz	350MHz	3.5x	
266MHz	400MHz	4x	
300MHz	450MHz	4.5x	

Processor		Frequency Ratio	SW1
66MHz	100MHz		
333MHz	Future processor	5x	
Future processor	Future processor	5.5x	
Future processor	Future processor	6x	
Future processor	Future processor	6.5x	
Future processor	Future processor	7x	
Future processor	Future processor	7.5x	
Future processor	Future processor	8x	



Note:

Intel Pentium® II processor or Intel Celeron™ processor supports VID (Voltage Identification). The switching voltage regulator on the system board will automatically set the voltage regulator according to the voltage of the processor.

2.2.3 Jumper Settings for CPU Front Side Bus

Jumper JP3

CPU Front Side Bus Select

The default is set at 1-2 On, Auto. The system will automatically set the bus speed according to the FSB of the processor. If it is Off, FSB is set to 100MHz.

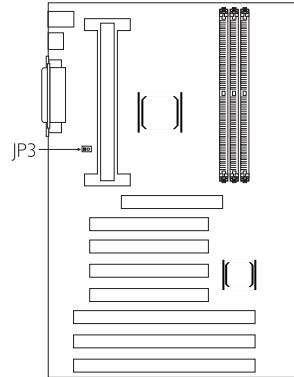

Warning:

If you set JP3 to Off for 66MHz FSB processor, it will provide better system performance. However, we do not guarantee that the system will work properly.



On : Auto(default)



Off : 100MHz

2.2.4 Jumper Settings for CMOS Clear

Jumper JP5

CMOS Clear

If, for some reason, the CMOS data becomes corrupted, the system can be reconfigured with the default values stored in the ROM BIOS. To load the default values, power-off your system and **unplug the power cord**. Set JP5 pins 2 and 3 to On. Wait for a few seconds and set JP5 back to its default setting, pins 1 and 2 On. You may now plug the power cord and power-on your system.

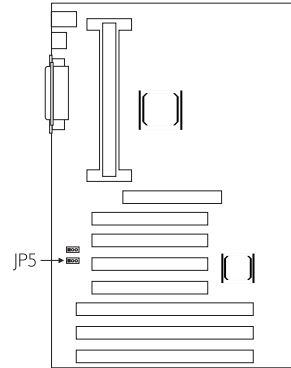

1-2 On:
Normal (default)



2-3 On:
Clear CMOS Data

2.2.5 Jumper Settings for Wake-On-Keyboard/ Wake-On-Mouse

Jumper JP7
Wake-On-Keyboard/Wake-On-Mouse

The system board supports the Wake-On-Keyboard/Wake-On-Mouse function. This function allows the keyboard or mouse to power-on the system. By default, JP7 is disabled. Make sure “Keyboard/Mouse Power On” in the Integrated Peripherals setup of the Award BIOS is also disabled.

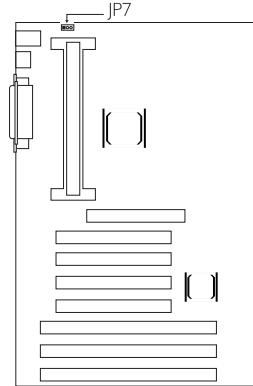

1-2 On: Disable (default)



2-3 On: Enable



Warning:

1. If JP7 was previously enabled with a password set in the BIOS setup, and now you wish to disable the Wake-On-Keyboard function, make sure to disable the password in the BIOS setup prior to setting JP7 to disabled. You will not be able to boot up the system if you fail to do so.
2. The power button will not function once a keyboard password has been set in the “KB Power On Password” field of the Integrated Peripherals setup. To power-on the system, you must type the password then press <Enter>.
3. The 5VSB power source of your power supply must support $\geq 720\text{mA}$ (minimum).

2.2.6 Installing Expansion Cards

1. Switch off your computer's power.
2. Remove your computer's cover.
3. Locate for a free expansion slot on the system board. Remove the screw and slot cover. Save the slot cover for future use. You will be using the screw in step 6.
4. Unpack the expansion card.
5. Refer to the expansion card's user's manual for any hardware settings such as jumpers.
6. Position the expansion card above the free slot. When the card's edge-connector is aligned with the slot, press firmly on the top of the card to seat it. Secure it with the screw you removed in step 3.
7. Replace the computer's cover and switch on the power.

2.2.6.1 Assigning an IRQ for an Expansion Card

If your expansion card need an IRQ, make sure to assign an IRQ that has not been used yet. Refer to the expansion card manual to determine whether an IRQ is needed.

The system has a total of 16 IRQs but most of them have been used by different components on the system leaving only 6 free IRQs available for expansion cards.

There are 2 types of ISA cards: Legacy (configured manually using jumpers) and PnP (IRQs are assigned automatically). When both types of cards exist, assign an IRQ for the Legacy cards first. The PnP card will then automatically be assigned an IRQ that has not been used by the Legacy cards.

After all ISA cards have been assigned an IRQ, the PCI cards will then be automatically assigned an IRQ.

Refer to the "Resources Controlled By" field in the PNP/PCI Configuration setup of the Award BIOS for more information.

To view the used and free IRQs, run Microsoft's Diagnostic, MSD.EXE. MSD.EXE is in the Windows directory. If you are using Windows 95, double-click "My Computer" in the Windows 95 desktop. In "My Computer", select "Control Panel". In "Control Panel", select "System". In "System", select "Device Manager". In "Device Manager", select a device to view the interrupt and IRQ used.

2.2.6.2 Assigning a DMA Channel for an Expansion Card

The same method (described above) is applied when assigning a DMA channel to an expansion card. Refer to the "Resources Controlled By" field in the PNP/PCI Configuration setup of the Award BIOS for more information.

2.2.6.3 Expansion Slots

The system board is equipped with 1 dedicated AGP slot to support high performance 3D graphics cards. Refer to the "Technology" section (Chapter 1) for more information.

The system board is also equipped with 3 dedicated PCI slots, 2 dedicated 16-bit ISA slot and 1 shared PCI/ISA slot. All PCI and ISA slots are bus masters.

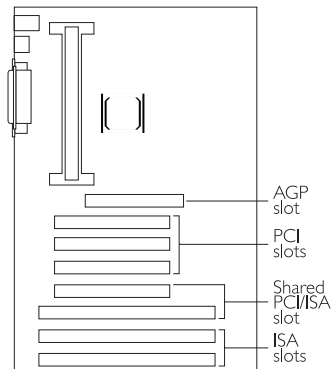

2.2.7 Connecting the Ribbon Cables and Wires of the Ports and Connectors

2.2.7.1 Serial Ports

The built-in serial ports are RS-232C asynchronous communication ports with 16C550A-compatible UARTs that can be used with modems, serial printers, remote display terminals, and other serial devices. You can set the serial ports' I/O address in the Integrated Peripherals setup of the Award BIOS.

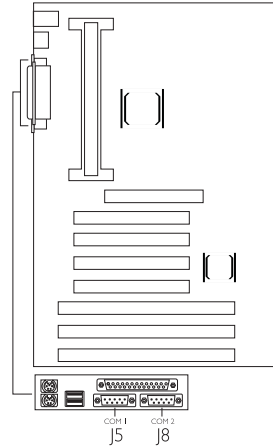

2.2.7.2 PS/2 Mouse Port

The PS/2 mouse port uses IRQ12. If a mouse is not connected to this port, the system will reserve IRQ12 for other expansion cards.

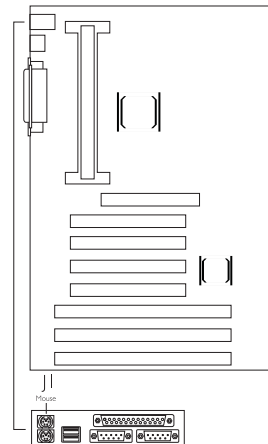

2.2.7.3 Parallel Port

The system board has a standard printer port for interfacing your PC to a parallel printer. It supports SPP, ECP and EPP modes. You can set the port's mode in the Integrated Peripherals setup of the Award BIOS.

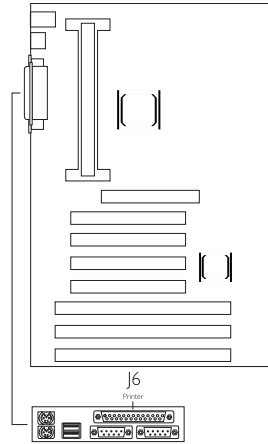

Setting	Function
SPP (Standard Parallel Port)	Allows normal speed operation but in one direction only.
ECP (Extended Capabilities Port)	Allows parallel port to operate in bidirectional mode and at a speed faster than the SPP's data transfer rate.
EPP (Enhanced Parallel Port)	Allows bidirectional parallel port operation at maximum speed.

2.2.7.4 Floppy Disk Drive Controller

The system board is equipped with a shrouded floppy disk header that supports two standard floppy disk drives. To prevent improper floppy cable installation, the shrouded floppy disk header has a keying mechanism. The 34-pin connector on the floppy cable can be placed into the header only if pin 1 of the connector is aligned with pin 1 of the header.

Connecting the Floppy Disk Cable

1. Install the 34-pin header connector into the shrouded floppy disk header (J9) on the system board. The colored edge of the ribbon should be aligned with pin 1 of J9.
2. Install the other 34-pin header connector(s) into the disk drive(s). Align the colored edge of the daisy chained ribbon cable with pin 1 of the drive edge connector(s). The end-most connector should be attached to the drive you want to designate as Drive A.

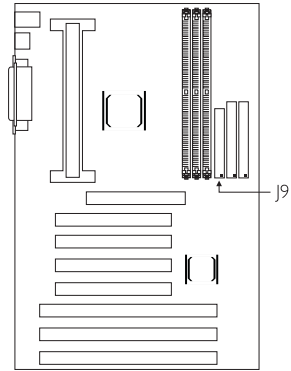

2.2.7.5 IDE Hard Disk Interface

The system board is equipped with two shrouded PCI IDE headers that will interface four Enhanced IDE (Integrated Drive Electronics) hard disk drives. To prevent improper IDE disk installation, each shrouded PCI IDE header has a keying mechanism. The 40-pin connector on the IDE cable can be placed into the header only if pin 1 of the connector is aligned with pin 1 of the header.

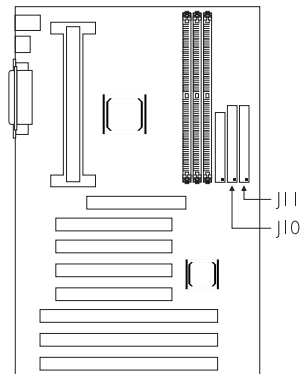

Note:

An IDE cable with a standard 40-pin connector (without the keying mechanism) can be installed in the shrouded IDE header. Be extremely careful to match the colored edge of the ribbon with pin 1 of the header.

Connecting the Hard Disk Cable

1. If you are connecting two hard drives, install the 40-pin connector of the IDE cable into the primary shrouded IDE header (connector J11). If you are adding a third or fourth IDE device, install the 40-pin connector of the other IDE cable into the secondary shrouded IDE header (connector J10).
2. Install the other 40-pin header connector(s) into the device with the colored edge of the ribbon cable aligned with pin 1 of the drive edge connector(s).



Note:

Refer to your disk drive user's manual for information about selecting proper drive switch settings.

Adding a Second IDE Hard Drive

When using two IDE drives, one must be set as the master and the other as the slave. Follow the instructions provided by the drive manufacturer for setting the jumpers and/or switches on the drives.

We recommend that you use Enhanced IDE or ATA-2, ATA-3 and Ultra DMA hard drives be from the same manufacturer. In a few cases, drives from two different manufacturers will not function properly when used together. The problem lies in the hard drives, not the system board.



Important:

If you encountered problems while using an ATAPI CD-ROM drive that is set in Master mode, please set the CD-ROM drive to Slave mode. Some ATAPI CD-ROMs may not be recognized and cannot be used if incorrectly set in Master mode.

Preparing an IDE Drive for Use

IDE disk drives are already low-level formatted, with any bad-track errors entered, when shipped by the drive manufacturer. Do not attempt to do a low-level format or you may cause serious damage to the drive.

To use an IDE drive, you need to enter the drive type (this information is provided by the drive manufacturer) into the system's CMOS setup table. Then run FDISK and FORMAT provided with your operating system. You may also use the "IDE HDD Auto Detection" function which will allow the BIOS to auto detect your hard drive type. Refer to the Chapter 3 - IDE HDD Auto Detection section for details.



Warning:

Do not run FDISK and FORMAT programs on a drive that has already been formatted or you will lose all programs and data stored on the drive.

2.2.7.6 Universal Serial Bus Ports

The system board is equipped with two USB ports. USB allows data exchange between your computer and a wide range of simultaneously accessible external Plug and Play peripherals.

You must have the proper drivers installed in your operating system to use these ports. Refer to your operating system's manual or documentation.

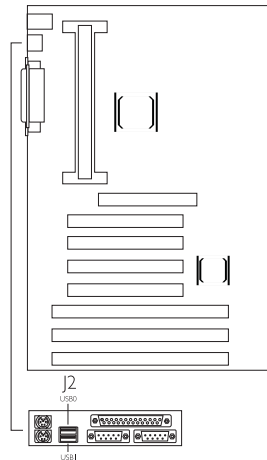

2.2.7.7 IrDA Connector

The system board is equipped with an IrDA connector for wireless connectivity between your computer and peripheral devices. Connect your IrDA cable to connector J16 on the system board. Refer to “UART2 Mode Select” in the Integrated Peripherals setup (Chapter 3). You must have the proper drivers installed in your operating system to use this connector. Refer to your operating system’s manual or documentation.

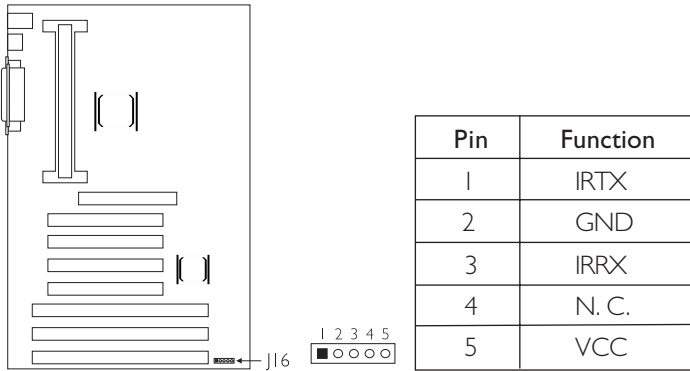

2.2.7.8 CPU Fan Connector

The processor must be kept cool by using a fan with heatsink. Connect the CPU fan to the 3-pin fan connector at location J7 on the system board.

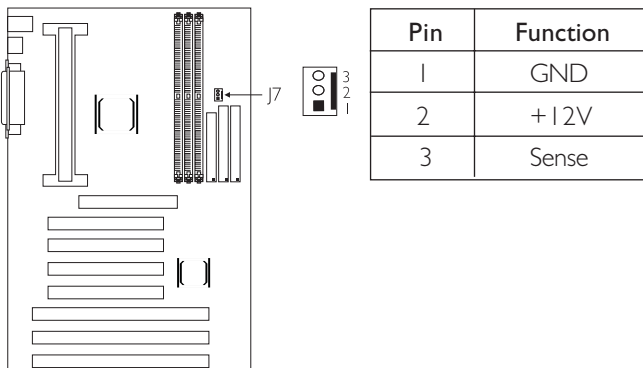

2.2.7.9 Chassis Fan Connector

The system board is equipped with a chassis fan connector. If you are installing a fan in the system unit, connect the fan's connector to location J3 on the system board. The fan will provide adequate airflow throughout the chassis to prevent overheating the processor.

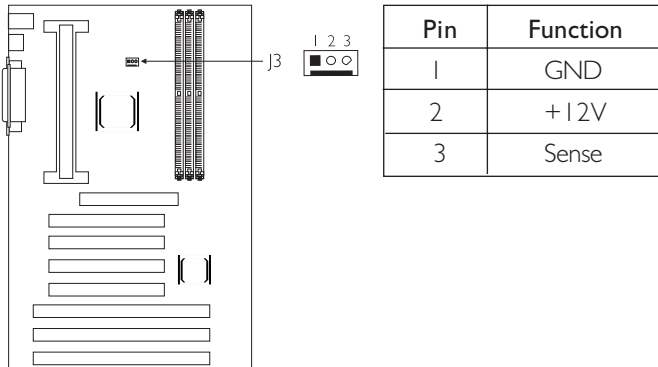

2.2.7.10 AGP Fan Connector

The system board is equipped with an AGP fan connector. If the system board is installed with an AGP add-in card and you wish to install a fan on the add-in card, connect the fan's connector to location J12 on the system board. Refer to the add-in card's manual for instructions on installing the fan.

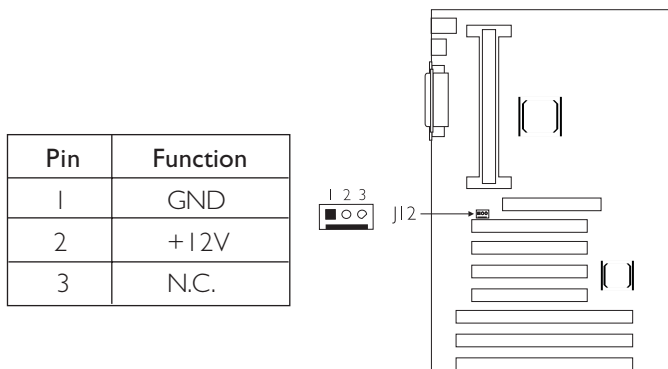

2.2.7.11 J13 (LEDs and Switches)

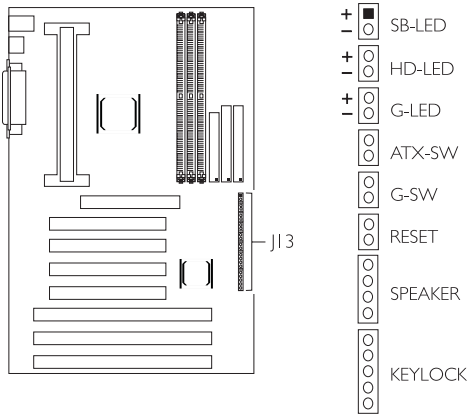

	Pin	Pin Assignment
SB-LED (ATX power LED)	1	ATX Power
	2	Ground
	3	Open
HD-LED (Primary/Secondary IDE LED)	4	HDD LED Power
	5	HDD
	6	Open
G-LED (Green LED)	7	Green LED Power
	8	Green
	9	Open
ATX-SW (ATX power switch)	10	PWRBTT
	11	Ground
	12	Open
G-SW (Green switch)	13	SMI
	14	Ground
	15	Open
RESET (Reset switch)	16	H/W Reset
	17	Ground
	18	Open

	Pin	Pin Assignment
SPEAKER (Speaker connector)	19	Speaker Data
	20	N. C.
	21	Ground
	22	Speaker Power
	23	Open
KEYLOCK (Keylock Connector)	24	LED Power
	25	N.C.
	26	Ground
	27	Keylock
	28	Ground

ATX Power LED

This LED will light when the 5VSB power is active.

Primary/Secondary IDE LED

This LED will light when the hard drive is being accessed.

Green LED

This LED will light when the system is in the Suspend mode.

ATX Power Switch

Depending on the setting in the BIOS setup, this switch is a “dual function power button” that will allow your system to enter the Soft-Off or Suspend mode. Refer to “Soft-Off By PWR-BTTN” in the Power Management Setup (Chapter 3).

Green Switch

This switch will allow your system to enter the Suspend mode. To wake up the system, “Reload Global Timer Events” in the Power Management Setup (Chapter 3) must be enabled so that access to the specified IRQ will cause the system to wake up completely from the Suspend mode.

Reset Switch

This switch allows you to reboot without having to power off the system thus prolonging the life of the power supply or system.

Speaker Connector

This connects to the speaker installed in the system chassis.

Keylock Connector

This is used to connect to the keyboard lock (located on the front panel of the system chassis) for locking the keyboard. Use pins 24 to 26 to connect to the Power LED.

2.2.7.12 SB-LINK™ Connector

If the system board is installed with a Creative sound card that requires connecting the card to the SB-LINK™ connector; connect the cable that came with the sound card to connector JP6. Refer to the sound card's manual for more information.

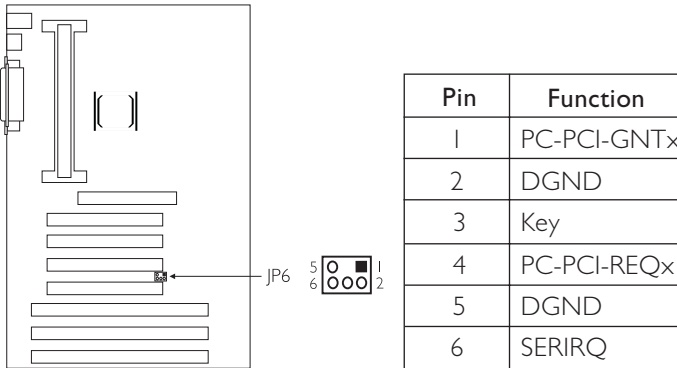

2.2.7.13 Power Connector

The system board is equipped with an ATX power connector at location J4 of the system board. Using an ATX power supply, you can either shut down your computer by pressing the Power button located on the front bezel of your computer or by executing the Shut Down command under the Windows® 95 operating system. Your system will enter the “soft power off” state. To power-on your system automatically, enable “Resume By Alarm” in the Power Management Setup of the Award BIOS. This will allow you to set the date and time you would like your system to power-on. Install the 20-pin ATX power cable connector into location J4 on the system board. The 20-pin connector can be inserted into J4 only if pin 1 of the connector is aligned with pin 1 of J4.

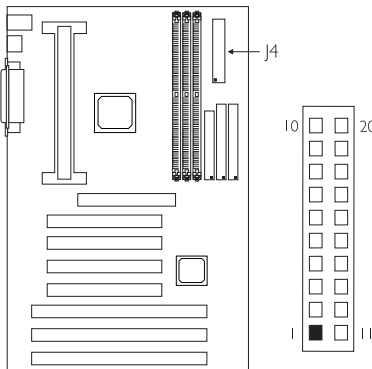

Pin	Function	Pin	Function
1	3.3V	11	3.3V
2	3.3V	12	-12V
3	COM	13	COM
4	5V	14	PS-ON
5	COM	15	COM
6	5V	16	COM
7	COM	17	COM
8	PW-OK	18	-5V
9	5VSB	19	5V
10	12V	20	5V



Important:

Your power supply must meet the ATX specification - supporting 3.3V/14A (minimum), otherwise your system will not boot properly.

2.2.7.14 Wake-On-LAN (WOL) Connector

The system board supports the Wake-On-LAN function. This function will allow the network to wake up a Soft Power Down (Soft-Off) PC. However, if your system is in the Suspend mode, you can wake-up the system only through an IRQ or DMA interrupt. To use the Wake-On-LAN function, you must enable the “Resume By LAN” field in the Power Management Setup of the Award BIOS. Connect the cable that comes with your LAN card to location J14 on the system board. Refer to the add-in card’s manual for details. Note: Your LAN card must support Magic Packet in order to use the Wake-On-LAN function.

Pin	Function
1	5VSB (720mA)
2	GND
3	Signal

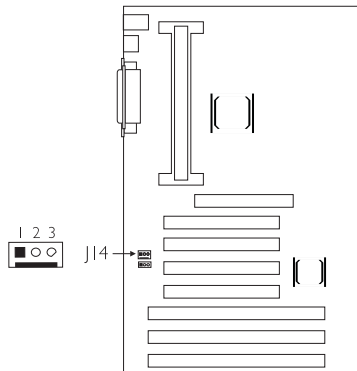

Important:

The 5VSB power source of your power supply must support $\geq 720\text{mA}$ (minimum).

2.2.8 Installing the System Board

1. After you have finished installing or upgrading the system board, install the system board into the chassis.
2. Install all expansion cards, cables and connectors.
3. Replace the system unit cover. Reconnect all power cords and cables.
4. You may now turn on the power of your system unit. After you power up your system, the BIOS message appears on your screen and the memory count begins. After the memory test, the following message will appear on the screen: *Press DEL to enter setup*. If the message disappears before you respond, restart your system or press the "Reset" button. You may also restart the system by pressing the <Ctrl> <Alt> and keys simultaneously.
5. Refer to Chapter 3 for descriptions on the BIOS setup.

Chapter 3 - Award BIOS Setup Utility

3.1 The Basic Input/Output System

The Basic Input/Output System (BIOS) is a program that takes care of the basic level of communication between the processor and peripherals. In addition, the BIOS also contain codes for various advanced features found in this system board. This chapter explains the Setup Utility for the Award BIOS.

After you power up your system, the BIOS message appears on your screen and the memory count begins. After the memory test, the following message will appear on the screen:

Press DEL to enter setup

If the message disappears before you respond, restart your system or press the "Reset" button. You may also restart the system by pressing the <Ctrl> <Alt> and keys simultaneously.

When you press , the main program screen will appear:

ROM PCI/ISA BIOS CMOS SETUP UTILITY AWARD SOFTWARE, INC.	
STANDARD CMOS SETUP BIOS FEATURES SETUP CHIPSET FEATURES SETUP POWER MANAGEMENT SETUP PNP/PCI CONFIGURATION LOAD FAIL-SAFE SETTINGS LOAD OPTIMAL SETTINGS	INTEGRATED PERIPHERALS SUPERVISOR PASSWORD USER PASSWORD IDE HDD AUTO DETECTION SAVE & EXIT SETUP EXIT WITHOUT SAVING
Esc : Quit F10 : Save & Exit Setup	↑↓→← : Select Item (Shift) F2 : Change Color

3.1.1 Standard CMOS Setup

Use the arrow keys to highlight "Standard CMOS Setup" and press <Enter>. A screen similar to the one on the next page will appear:

ROM PCI/ISA BIOS
STANDARD CMOS SETUP
AWARD SOFTWARE, INC.

Date (mm:dd:yy) : Mon, Jul 29 1996									
Time (hh:mm:ss) : 13: 27: 50									
HARD DISKS	TYPE	SIZE	CYLS	HEAD	PRECOMP	LANDZ	SECTOR	MODE	
Primary Master	: Auto	0	0	0	0	0	0	0	Auto
Primary Slave	: Auto	0	0	0	0	0	0	0	Auto
Secondary Master	: Auto	0	0	0	0	0	0	0	Auto
Secondary Slave	: Auto	0	0	0	0	0	0	0	Auto
Drive A : 1.44M, 3.5 in.									
Drive B : None									
Video : EGA/VGA								Base Memory : 640K	
Halt on : All Errors								Extended Memory : 64512K	
								Other Memory : 384K	
								Total Memory : 65536K	
Esc : Quit			↑↓→← : Select Item			PU/PD/+/- : Modify			
F10 : Save & Exit Setup			(Shift)F2 : Change						

The settings on the screen are for reference only. Your version may not be identical to this one.

Date

The date format is <day>, <month>, <date>, <year>. Day displays a day, from Sunday to Saturday. Month displays the month, from January to December. Date displays the date, from 1 to 31. Year displays the year, from 1994 to 2079.

Time

The time format is <hour>, <minute>, <second>. The time is based on the 24-hour military-time clock. For example, 1 p.m. is 13:00:00. Hour displays hours from 00 to 23. Minute displays minutes from 00 to 59. Second displays seconds from 00 to 59.

Primary Master, Primary Slave, Secondary Master and Secondary Slave

These categories allow you to enter the appropriate specifications for the type of hard disk drive(s) installed in your system. Press <PgUp> or <PgDn> to select a numbered hard disk type or type the number and press <Enter>. The hard disk will not work properly if you enter improper information for this category. You can use Type "User" to define your own drive type manually. This information should be included in the documentation from your hard disk vendor. If you select Type "Auto", the BIOS will auto-detect the HDD & CD-ROM drive at the POST stage and show the IDE for the HDD & CD-ROM drive. If a hard disk has not been installed, select "None" and press <Enter>.

Drive A and Drive B

These categories identify the types of floppy disk drives installed. Choosing an incorrect type might cause your system to format the floppy disk improperly and you cannot access your data. The options for drive A and B are:

<i>None</i>	No floppy drive is installed
<i>360K, 5.25 in.</i>	5-1/4 in. standard drive; 360KB capacity
<i>1.2M, 5.25 in.</i>	5-1/4 in. AT-type high-density drive; 1.2MB capacity
<i>720K, 3.5 in.</i>	3-1/2 in. double-sided drive; 720KB capacity
<i>1.44M, 3.5 in.</i>	3-1/2 in. double-sided drive; 1.44MB capacity
<i>2.88M, 3.5 in.</i>	3-1/2 in. double-sided drive; 2.88MB capacity

Video

This category selects the type of video adapter used for the primary system monitor. Although secondary monitors are supported, you do not have to select the type in Setup. The default setting is EGA/VGA (BIOS default, Setup default).

<i>EGA/VGA</i>	Enhanced Graphics Adapter/Video Graphics Array. For EGA, VGA, SVGA and PGA monitor adapters.
<i>CGA 40</i>	Color Graphics Adapter. Power up in 40-column mode.
<i>CGA 80</i>	Color Graphics Adapter. Power up in 80-column mode.
<i>Mono</i>	Monochrome adapter. Includes high resolution monochrome adapters.

Halt On

This category determines whether the system will stop if an error is detected during power up. The default setting is All, But Keyboard (BIOS default, Setup default).

<i>No Errors</i>	The system boot will not stop for any errors detected.
<i>All Errors</i>	The system boot will stop whenever the BIOS detects a non-fatal error.
<i>All, But Keyboard</i>	The system boot will not stop for a keyboard error; it will stop for all other errors.
<i>All, But Diskette</i>	The system boot will not stop for a disk error; it will stop for all other errors.
<i>All, But Disk/Key</i>	The system boot will not stop for a disk or keyboard error; it will stop for all other errors.

Memory

The base memory size, extended memory size and the other memory size cannot be altered; your computer automatically detects and displays them.

Base Memory The POST will determine the amount of base (or conventional) memory installed in the system. The value of the base memory is typically 512K for systems with 512K memory installed on the motherboard or 640K for systems with 640K or more memory installed on the motherboard.

Extended Memory The BIOS determines how much extended memory is present during the POST. This is the amount of memory located above 1MB in the CPU's memory address map.

Other Memory This refers to the memory located in the 640K to 1024K address space. This is the memory that can be used for different applications. DOS uses this area to load device drivers in an effort to keep as much base memory free for application programs. The BIOS is the most frequent user of this RAM area since this is where it shadows the ROM.

3.1.2 BIOS Features Setup

The BIOS Features Setup allows you to configure your system for basic operation. Some entries are defaults required by the system board, while others, if enabled, will improve the performance of your system or let you set some features according to your preference.

ROM PCI/ISA BIOS BIOS FEATURES SETUP AWARD SOFTWARE, INC.	
Virus Warning	: Disabled
CPU L1 Cache	: Enabled
CPU L2 Cache	: Enabled
CPU L2 Cache ECC Checking	: Enabled
Quick Power On Self Test	: Enabled
Boot Sequence	: A, C, SCSI
Swap Floppy Drive	: Disabled
Boot Up Floppy Seek	: Disabled
Boot Up NumLock Status	: On
Typeomatic Rate Setting	: Disabled
Typeomatic Rate (Chars/Sec)	: 6
Typeomatic Delay (Msec)	: 250
Security Option	: Setup
PCI/VGA Palette Snoop	: Disabled
OS Select For DRAM > 64MB	: Non-OS2
HDD S.M.A.R.T. Capability	: Disabled
ESC	: Quit ↑↓←→ : Select Item
F1	: Help PU/PD/+/- : Modify
F5	: Old Values (Shift) F2 : Color
F6	: Load Fail-Safe Settings
F7	: Load Optimal Settings

The settings on the screen are for reference only. Your version may not be identical to this one.

Virus Warning

This category protects the boot sector and partition table of your hard disk drive. When this item is enabled, the Award BIOS will monitor the boot sector and partition table of the hard disk drive. If an attempt is made to write to the boot sector or partition table of the hard disk drive, the BIOS will halt the system and an error message will appear.

After seeing the error message, if necessary, you will be able to run an anti-virus program to locate and remove the problem before any damage is done.

Many disk diagnostic programs which attempt to access the boot sector table will cause the warning message to appear. If you are running such a program, we recommend that you first disable this category. Also, disable this category if you are installing or running certain operating systems like Windows® 95 or the operating system may not install nor work.

CPU L1 Cache and CPU L2 Cache

These categories speed up the memory access. The default value is enabled. Enable the External Cache for better performance.

CPU L2 Cache ECC Checking

Intel Pentium® II processor comes with built-in Level 2 cache. By default, ECC is enabled to check the Level 2 cache. If you are not using this function, set this field to Disabled.

Quick Power On Self Test

This category speeds up Power On Self Test (POST) after you power on your system. When Enabled, the BIOS will shorten or skip some check items during POST.

Boot Sequence

This category determines which drive to search first for the disk operating system. The default is A, C, SCSI. The options are:

A, C, SCSI;	C, A, SCSI;	C, CDROM, A;	CDROM, C, A;
D, A, SCSI;	E, A, SCSI;	F, A, SCSI;	SCSI, A, C;
SCSI, C, A;	C only;	LSI 20/ZIP, C.	

Swap Floppy Drive

When this option is enabled and the system is booting from the floppy drive, the system will boot from drive B instead of drive A. When this option is disabled and the system is booting from the floppy drive, the system will boot from drive A. You must have two floppy drives to use this function.

Boot Up Floppy Seek

When enabled, the BIOS will check whether the floppy disk drive installed is 40 or 80 tracks. Note that the BIOS cannot distinguish between 720K, 1.2M, 1.44M and 2.88M drive types as they are all 80 tracks. When disabled, the BIOS will not search for the type of floppy disk drive by track number. Note that there will not be any warning message if the drive installed is 360KB.

Boot Up NumLock Status

This allows you to determine the default state of the numeric keypad. By default, the system boots up with NumLock on wherein the function of the numeric keypad is the number keys. When set to Off, the function of the numeric keypad is the arrow keys.

Typematic Rate Setting

When disabled, continually holding down a key on your keyboard will cause the BIOS to report that the key is down. When the typematic rate is enabled, the BIOS will not only report that the key is down, but will first wait for a moment, and, if the key is still down, it will begin to report that the key has been depressed repeatedly. For example, you would use such a feature to accelerate cursor movements with the arrow keys.

Typematic Rate (Chars/Sec)

This selection allows you to select the rate at which the keys are accelerated.

Typematic Delay (Msec)

This selection allows you to select the delay between when the key was first depressed and when the acceleration begins.

Security Option

System The system will not boot and access to Setup will be denied if the correct password is not entered at the prompt.

Setup The system will boot, but access to Setup will be denied if the correct password is not entered at the prompt.

PCI/VGA Palette Snoop

It determines whether the MPEG ISA/VESA VGA Cards can work with PCI/VGA or not. The default value is Disabled.

Enabled PCI/VGA working with MPEG ISA/VESA VGA cards.

Disabled PCI/VGA not working with MPEG ISA/VESA VGA cards.

OS Select for DRAM > 64MB

This item allows you to access the memory that is over 64MB in OS/2. The options are: Non-OS/2 and OS/2.

HDD S.M.A.R.T. Capability

The system board supports SMART (Self-Monitoring, Analysis and Reporting Technology) hard drives. SMART is a reliability prediction technology for ATA/IDE and SCSI drives. The drive will provide sufficient notice to the system or user to backup data prior to the drive's failure. The default is Disabled. If you are using hard drives that support S.M.A.R.T., set this field to Enabled. SMART is supported in ATA-3 or later hard drives.

3.1.3 Chipset Features Setup

ROM PCI/ISA BIOS
CHIPSET FEATURES SETUP
AWARD SOFTWARE, INC.

SDRAM RAS-to-CAS Delay	: 3	**** System Health Monitor ****
SDRAM RAS Precharge Time	: 3	Current CPU Temperature : 36°C/96°F
SDRAM CAS Latency Time	: 3	Current CPU Fan Speed : 5000 RPM
SDRAM Precharge Control	: Disabled	Current Chassis Fan Speed : 0 RPM
DRAM Data Integrity Mode	: Non-ECC	CPU Temperature Limit : Ignore
System BIOS Cacheable	: Disabled	CPU Fan Speed Limit : Ignore
Video BIOS Cacheable	: Disabled	Chassis Fan Speed Limit : Ignore
Video RAM Cacheable	: Disabled	+3.3V Voltage : Ignore
8 Bit I/O Recovery Time	: 1	+12V Voltage : Ignore
16 Bit I/O Recovery Time	: 1	+5V Voltage : Ignore
Memory Hole At 15M-16M	: Disabled	+1.5V Voltage : Ignore
PCI 2.1 Compliance	: Disabled	
AGP Aperture Size (MB)	: 64	
CPU Clock Frequency	: Default	
Spread Spectrum	: Disabled	
		ESC : Quit ↑ ↓ → ← : Select Item
		F1 : Help PU/PD/+/- : Modify
		F5 : Old Values (Shift) F2 : Color
		F6 : Load Fail-Safe Settings
		F7 : Load Optimal Settings

The settings on the screen are for reference only. Your version may not be identical to this one.

This section gives you functions to configure the system based on the specific features of the chipset. The chipset manages bus speeds and access to system memory resources. It also coordinates communications between the conventional ISA bus and the PCI bus. **These items should not be altered unless necessary.** The default settings have been chosen because they provide the best operating conditions for your system. The only time you might consider making any changes would be if you discovered some incompatibility or that data was being lost while using your system.

SDRAM RAS-to-CAS Delay

This field allows you to insert a timing delay between the CAS and RAS strobe signals, used when DRAM is written to, read from, or refreshed. This field applies only when synchronous DRAM is installed in the system.

SDRAM RAS Precharge Time

If there is insufficient number of cycles for the RAS to accumulate its charge before DRAM refresh, the refresh may be incomplete and the DRAM may fail to retain data.

SDRAM CAS Latency Time

The default setting is 3 which is 3 clock cycles for the CAS latency.

DRAM Data Integrity Mode

The system board supports EC and ECC (Error Checking and Correction) functions. EC or ECC is supported only in x72 (72-bit) PC SDRAM DIMMs. If you are using x64 (64-bit) PC SDRAM DIMMs, set this field to Non-ECC.

Non-ECC Uses x64 PC SDRAM DIMM.

EC Only detects, but does not correct data errors.

ECC This option allows the system to recover from memory failure. It detects single-bit and multiple-bit errors, then automatically corrects single-bit error.

System BIOS Cacheable

When this option is enabled, accesses to the system BIOS ROM addressed at F0000H-FFFFFH are cached, provided that the cache controller is enabled. The larger the range of the Cache RAM, the higher the efficiency of the system.

Video BIOS Cacheable

As with caching the system BIOS, enabling the Video BIOS cache will allow access to video BIOS addressed at C0000H to C7FFFH to be cached, if the cache controller is also enabled. The larger the range of the Cache RAM, the faster the video performance.

Video RAM Cacheable

When enabled, it allows the video RAM to be cacheable thus providing better video performance. If your graphics card does not support this function, leave this field in its default setting - Disabled.

8 Bit I/O Recovery Time and 16 Bit I/O Recovery Time

The recovery time is the length of time, measured in SYSCLK, which the system will delay after the completion of an input/output request. This delay takes place because the CPU is operating so much faster than the input/output bus that the CPU must be delayed to allow for

the completion of the I/O. This item allows you to determine the recovery time allowed for 8-bit I/O or 16-bit I/O.

Memory Hole At 15M-16M

In order to improve system performance, certain space in memory can be reserved for ISA cards. This memory must be mapped into the memory space below 16MB. When enabled, the CPU assumes the 15-16MB memory range is allocated to the hidden ISA address range instead of the actual system DRAM. When disabled, the CPU assumes the 15-16MB address range actually contains DRAM memory. If more than 16MB of system memory is installed, this option must be disabled to provide contiguous system memory.

PCI 2.1 Compliance

By default, this field is Disabled. However, if you encounter problems with your PCI card, try setting this field to Enabled. It may be that your card is PCI 2.1 compliant.

AGP Aperture Size (MB)

This field is relevant to the memory-mapped graphics data of the AGP card installed in your system. Leave this in its default setting, which is 64MB.

CPU Clock Frequency

By default, the "CPU Clock Frequency" field is set to "Default". Under this setting, the system will run at 66MHz or 100MHz, depending on the processor's clock frequency. However, if you selected another option in this field and the system will not boot, you may clear the data stored in the ROM BIOS by following the instructions in section 2.2.4 (chapter 2). Or you may press "Insert" key and Power button simultaneously to use default FSB and then enter CMOS Setup to set "CPU Clock Frequency" field to Default. This will allow the "CPU Clock Frequency" field to return to its default setting.

Spread Spectrum

Leave this field in its default setting - Disabled. Do not alter this setting unless advised by an engineer or technician.

System Health Monitor



Note:

The system board comes with a System Health Monitor utility. Once this utility is installed, the system will ignore the settings in the “System Health Monitor” field of the Chipset Features Setup.

If you are using Windows® 95 or Windows NT® 4.0, you may select between using the utility and the Chipset Features Setup. For other operating systems, you may only use the Chipset Features Setup. Refer to the “System Health Monitor Utility” section (Chapter 4) for more information.

Current CPU Temperature, Current CPU Fan Speed and Current Chassis Fan Speed

These fields show the current temperature of the processor, and the current fan speed of the CPU and chassis fans in RPM (Revolutions Per Minute).

CPU Temperature Limit

This field allows you to manually set a limit to the processor's temperature. If the temperature of the processor is over the temperature set in this field (70°C/158°F recommended), an alarm will sound warning you of system overheat. The sound of the alarm is continuous low to high beeps. Some of the most common causes leading to high temperature are:

- The fan is not functioning normally or has stopped. Turn off your system and replace the fan.
- The space clearance of the processor, fan and heat sink is inadequate to maintain proper airflow and heat dissipation.
- The chassis or cabinet has poor ventilation.

CPU Fan Speed Limit and Chassis Fan Speed Limit

These fields allow you to manually set a limit to the speed of the CPU and chassis fans. If the CPU/chassis fan speed is under the speed set in these fields, an alarm will sound informing you to attend to any issue that may damage your system. The sound of the alarm resembles that of the siren of an ambulance. The “failure detection” circuit requires a fan to operate at greater than 3600 RPM.

+1.5V, +3.3V, +5V and +12V Voltages

Set these fields to "Monitor" if you want the system board to detect the output voltage of the power supply. If the output voltage is over or under +1.5V/+3.3V/+5V/+12V ($\pm 10\%$), an alarm will sound warning you of voltage issue. The sound of the alarm is continuous low to high beeps but shorter than the temperature alarm. Some of the most common causes leading to unstable output voltage of a power supply are:

- The power supply is not functioning normally. Turn off your system and replace the power supply.
- The AC input from the power outlet to your system is unstable. Please consult your MIS department or an electrician.

3.1.4 Power Management Setup

The Power Management Setup allows you to configure your system to most effectively save energy. If you like to use the soft power down feature of Windows 95, you must enable the Power Management below. Select Min. Power, Max. Power or User Defined. Either one can be used as long as it is NOT disabled.

ROM PCI/ISA BIOS POWER MANAGEMENT SETUP AWARD SOFTWARE, INC.	
ACPI Function	: Disabled
Power Management	: User Define
PM Control by APM	: Yes
Video Off Method	: DPMS
Video Off After	: Suspend
MODEM Use IRQ	: 3
Standby Mode	: Disabled
Suspend Mode	: Disabled
HDD Power Down	: Disabled
VGA Active Monitor	: Disabled
Soft-Off by PWR-BTTN	: Instant-Off
Resume by Ring	: Disabled
Resume by LAN	: Disabled
Resume by Alarm	: Disabled
ESC : Quit ↑ ↓ → ← : Select Item F1 : Help PU/PD/+/- : Modify F5 : Old Values (Shift) F2 : Color F6 : Load Fail-Safe Settings F7 : Load Optimal Settings	

The settings on the screen are for reference only. Your version may not be identical to this one.

ACPI Function

By default, the ACPI function is disabled. This function should be enabled only in operating systems that support ACPI such as Windows® 98 and Windows NT® 5.0.

Power Management

This category allows you to select the type (or degree) of power saving by changing the length of idle time that elapses before the Standby mode and Suspend mode are activated.

Disable No power management. Disables the Standby and Suspend modes.

Min. Power Saving Minimum power management. Standby Mode = 1 hr., and Suspend Mode = 1 hr.

Max. Power Saving Maximum power management. Standby Mode = 1 min., and Suspend Mode = 1 min.

User Defined Allows you to set each mode individually. When enabled, each option ranges from 1 min. to 1 hr.

PM Control by APM

Yes An Advanced Power Management device will be activated to enhance the Max. Power Saving mode and stop the CPU's internal clock. Use this option in Windows® 95. (default)

No The system BIOS will ignore APM when initiating the Power Management mode.

Video Off Method

This determines the manner in which the monitor is blanked.

V/H SYNC + Blank This selection will cause the system to turn off the vertical and horizontal synchronization ports and write blanks to the video buffer:

Blank Screen This option only writes blanks to the video buffer:

DPMS Initializes display power management signaling. Use this option if your video board supports it.

Video Off After

- | | |
|----------------|---|
| <i>N/A</i> | The system BIOS will never turn off the screen. |
| <i>Suspend</i> | The screen is off when the system is in the Suspend mode. |
| <i>Standby</i> | The screen is off when the system is in the Standby mode. |
| <i>Doze</i> | The screen is off when the system is in the Doze mode. |

MODEM Use IRQ

This category is used to set an IRQ channel (IRQ 3, 4, 5, 7, 9, 10 or 11) for the modem installed in your system.

Standby Mode

This is user configurable only when the Power Management category is set to User Defined. When enabled and after the set time of system inactivity, the CPU clock will run at a speed slower than the speed during Doze mode (1/3 of full speed) while all other devices still operate at full speed.

Suspend Mode

This is user configurable only when the Power Management category is set to User Defined. When enabled and after the set time of system inactivity, the CPU and onboard peripherals will be shut off.

HDD Power Down

This is user configurable only when the Power Management category is set to User Defined. When enabled and after the set time of system inactivity, the hard disk drive will be powered down while all other devices remain active.

VGA Active Monitor

- | | |
|-----------------|---|
| <i>Enabled</i> | VGA activities will cause the system to wake up from power saving mode. |
| <i>Disabled</i> | VGA activities will not cause the system to wake up from power saving mode. |

Soft-Off by PWR-BTTN

This category allows you to select the method of powering off your system.

Hold 4 Sec. Regardless of whether the Power Management field is enabled or disabled, if the power button is pushed and released in less than 4 sec, the system enters the Suspend mode. The purpose of this function is to prevent the system from powering off in case you accidentally “hit” or pushed the power button. Pushing the power button for more than 4 seconds will power off the system.

Instant-Off Pressing and then releasing the power button at once will immediately power off your system.

Resume By Ring

With an external modem installed, the Modem Ring-on function allows your system to power-on to respond to incoming calls. To use this function, set this field to Enabled.

Resume By LAN

With a LAN card installed, the Wake-On-LAN function allows the network to wake up a Soft Power Down (Soft-Off) PC. However, if your system is in the Suspend mode, you can wake-up the system only through an IRQ or DMA interrupt. To use this function, set this field to Enabled. Refer to the “Wake-On LAN Connector” section in Chapter 2 of this manual for more information.

Resume By Alarm

Enabled When Enabled, you can set the date and time you would like the Soft Power Down (Soft-Off) PC to wake up. However, if the system is being accessed by incoming calls or the network (Resume By Ring/LAN) prior to the date and time set in this field, the system will give priority to the incoming calls or network. “Date (of Month)” and “Timer (hh:mm:ss)” will appear right below this field.

Disabled Disables the automatic wake up function. (default)

Date (of Month)

- 0 The system will power-on everyday according to the time set in the "Timer (hh:mm:ss)" field.
- 1-31 Select a date you would like the system to power-on. The system will power-on on the set date, and time set in the "Timer (hh:mm:ss)" field.

Timer (hh:mm:ss)

This is used to set the time you would like the system to power-on. If you want the system to power-on everyday as set in the "Date (of Month)" field, the time set in this field must be later than the CMOS RTC's time.

3.1.5 PNP/PCI Configuration

This section describes configuring the PCI bus system. It covers some very technical items and it is strongly recommended that only experienced users should make any changes to the default settings.

ROM PCI/ISA BIOS PNP/PCI CONFIGURATION AWARD SOFTWARE, INC.	
Resources Controlled By : Auto	Assign IRQ for VGA : Enabled
Reset Configuration Data : Disabled	Assign IRQ for USB : Enabled
	PCI Slot 1 IRQ : Auto
	PCI Slot 2 IRQ : Auto
	PCI Slot 3 IRQ : Auto
	PCI Slot 4 IRQ : Auto
ESC : Quit ↑ ↓ → ← : Select Item F1 : Help PU/PD/+/- : Modify F5 : Old Values (Shift) F2 : Color F6 : Load Fail-Safe Settings F7 : Load Optimal Settings	

The settings on the screen are for reference only. Your version may not be identical to this one.

Resources Controlled By

The Award Plug and Play BIOS has the capability to automatically configure all of the boot and Plug and Play compatible devices.

- Auto* The system will automatically detect the settings for you. The categories that follow will not be shown on the screen.
- Manual* This will allow you to set the IRQ/DMA (you have assigned your add-in card) to Legacy ISA or PCI/ISA PnP. For non-PnP ISA cards, select Legacy ISA. For PnP ISA or PCI cards, select PCI/ISA PnP.

Reset Configuration Data

- Enabled* The BIOS will reset the configuration data once automatically. It will then recreate a new set of configuration data.
- Disabled* The BIOS will not reset the configuration data.

Assign IRQ for VGA

When Enabled, the system automatically assigns an IRQ for the VGA card installed. Your VGA card will need an IRQ only when using the video capture function of the card. If you are not using this function and a new device requires an IRQ, you can set this function to Disabled. The IRQ (previously occupied by the VGA card) will be available for your new device.



Note:

When Disabled, a "Yellow" mark will appear in Windows® 95's Device Manager.

Assign IRQ for USB

When Enabled, the system automatically assigns an IRQ for the USB device connected to your system. However, if you are not using USB devices and an ISA slot requires an IRQ, set this function to Disabled. The IRQ previously occupied by the USB device will be available for the ISA slot.

**Note:**

When Disabled, a “Yellow” mark will appear in Windows® 95's Device Manager.

PCI Slot 1 IRQ to PCI Slot 4 IRQ

By default, an IRQ is automatically assigned to each PCI slot. You may also specify an IRQ to these slots. The options are: 3, 4, 5, 7, 9, 10, 11, 12, 14 and 15.

3.1.6 Load Fail-Safe Settings

The “Load Fail-Safe Settings” option loads the troubleshooting default values permanently stored in the ROM chips. These settings are not optimal and turn off all high performance features. You should use these values only if you have hardware problems. Highlight this option on the main menu and press <Enter>. The message below will appear:

Load Fail-Safe Settings (Y/N)? N

If you want to proceed, type <Y> and press <Enter>. The default settings will be loaded.

3.1.7 Load Optimal Settings

The “Load Optimal Settings” option loads optimized settings from the BIOS ROM. Use the Setup default values as standard values for your system. Highlight this option on the main menu and press <Enter>. The message below will appear:

Load Optimal Settings (Y/N)? N

Type <Y> and press <Enter> to load the Setup default values.

3.1.8 Integrated Peripherals

ROM PCI/ISA BIOS
INTEGRATED PERIPHERALS
AWARD SOFTWARE, INC.

IDE HDD Block Mode	: Enabled	KBC Input Clock	: 8MHz
IDE Primary Master PIO	: Auto	Onboard FDC Controller	: Enabled
IDE Primary Slave PIO	: Auto	Onboard Serial Port 1	: 3F8/IRQ4
IDE Secondary Master PIO	: Auto	Onboard Serial Port 2	: 2F8/IRQ5
IDE Secondary Slave PIO	: Auto	UART2 Mode Select	: Normal
IDE Primary Master UDMA	: Auto		
IDE Primary Slave UDMA	: Auto	Onboard Parallel Port	: 378/IRQ7
IDE Secondary Master UDMA	: Auto	Parallel Port Mode	: ECP+EPP
IDE Secondary Slave UDMA	: Auto	ECP Mode Use DMA	: 3
On-chip Primary PCI IDE	: Enabled	EPP Mode Select	: EPP1.7
On-chip Secondary PCI IDE	: Enabled	Keyboard/Mouse Power On	: Disabled
USB Keyboard Support	: Disabled		
Init Display First	: AGP		
		ESC	: Quit
		F1	: Help
		F5	: Old Values (Shift)
		F6	: Load Fail-Safe Settings
		F7	: Load Optimal Settings
		↑ ↓ → ←	: Select Item
		PU/PD/+/-	: Modify
			: Color

The settings on the screen are for reference only. Your version may not be identical to this one.

IDE HDD Block Mode

Enabled The IDE HDD uses the block mode. The system BIOS will check the hard disk drive for the maximum block size the system can transfer. The block size will depend on the type of hard disk drive.

Disabled The IDE HDD uses the standard mode.

IDE Primary Master/Slave PIO and IDE Secondary Master/Slave PIO

PIO means Programmed Input/Output. Rather than have the BIOS issue a series of commands to effect a transfer to or from the disk drive, PIO allows the BIOS to tell the controller what it wants and then let the controller and the CPU perform the complete task by themselves. Your system supports five modes, 0 (default) to 4, which primarily differ in timing. When Auto is selected, the BIOS will select the best available mode after checking your drive.

Auto The BIOS will automatically set the system according to your hard disk drive's timing.

0-4 You can select a mode that matches your hard disk drive's timing. Caution: Do not use the wrong setting or you will have drive errors.

IDE Primary Master/Slave UDMA and IDE Secondary Master/Slave UDMA

These categories allow you to set the Ultra DMA in use. When Auto is selected, the BIOS will select the best available option after checking your hard drive or CD-ROM.

- Auto* The BIOS will automatically detect the settings for you.
- Disabled* The BIOS will not detect these categories.

On-Chip Primary PCI IDE and On-Chip Secondary PCI IDE

These categories allow you to enable or disable the primary and secondary IDE controller. The default is Enabled. Select Disabled if you want to add a different hard drive controller.

USB Keyboard Support

By default, USB Keyboard Support is Disabled. If you are operating under DOS, make sure to enable this function.

Init Display First

This field applies only to systems installed with both PCI and AGP cards. It allows you to select which one to initialize first when the system boots.

- AGP* When the system boots, it will first initialize AGP.
- PCI Slot* When the system boots, it will first initialize PCI.

KBC Input Clock

This is used to select the input clock of your keyboard. The options are: 6MHz, 8MHz, 12MHz and 16MHz. The default is 8MHz.

Onboard FDC Controller

- Enabled* Enables the onboard floppy disk controller.
- Disabled* Disables the onboard floppy disk controller.

Onboard Serial Port 1 and Onboard Serial Port 2

Auto The system will automatically select an I/O address for the onboard serial port 1 and serial port 2.

3F8/IRQ4, 2F8/IRQ3, 3E8/IRQ4, 2E8/IRQ3 Allows you to manually select an I/O address for the onboard serial port 1 and serial port 2.

Disabled Disables the onboard serial port 1 and/or serial port 2.

UART2 Mode Select

The system board supports IrDA function for wireless connectivity between your computer and peripheral devices. You may not use IrDA (J16) and the COM 2 serial port (J8) at the same time. If you are using the COM 2 serial port, make sure "UART2 Mode Select" is set to Normal.

To use the IrDA function, follow the steps below.

1. Connect your IrDA cable to connector J16 on the system board.
2. Set "UART2 Mode Select" to the type of IrDA standard supported by your IrDA peripheral/device (IrDA or ASKIR).
3. The following will appear right after "UART2 Mode Select".

IR Transmission Delay

If this option is Enabled, transmission of data will be slower. This is recommended when you encounter transmission problem with your device. The options are: Enabled and Disabled.

Onboard Parallel Port

378H/IRQ7, 3BCH/IRQ7, 278H/IRQ5 Selects the I/O address and IRQ for the onboard parallel port.

Disabled Disables the onboard parallel port.

Parallel Port Mode

Parallel Port Mode will appear only if you selected an I/O address and IRQ in the Onboard Parallel Port field. This option applies to a standard specification and will depend on the type and speed of your

device. Refer to your peripheral's manual for the best option. Select the parallel port mode according to the type of printer device connected to your onboard parallel port.

The parallel modes are SPP, EPP, ECP and ECP+EPP. The default is ECP+EPP. Both "ECP Mode Use DMA" and "EPP Mode Select" will appear on the screen. If you selected EPP, "EPP Mode Select" will appear. This field applies to standard specification. The options are EPP1.9 and EPP1.7. Default setting: EPP1.7. If you selected ECP, "ECP Mode Use DMA" will appear. This is used to select a DMA channel for the parallel port. The options are 1 and 3. Default setting: 3.

Keyboard/Mouse Power On

This field allows you to use the keyboard or mouse to power-on the system. To use this function, make sure JP7 is set to 2-3 On - the Wake-On-Keyboard/Mouse function enabled. Refer to "Jumper Settings for Wake-On-Keyboard/Wake-On-Mouse" in Chapter 2 of this manual for more information.

Disabled

Default setting:



Warning:

If JP7 was previously enabled with a password set in this field, and now you wish to disable the "password" function, make sure to set this field to Disabled prior to setting JP7 to 1-2 On - Disabled, otherwise you will not be able to boot up the system.

Password

When this option is selected, the "KB Power On Password" field will appear. Move the cursor to this field and press <Enter>. Enter your password. You can enter up to 5 characters. Type in exactly the same password to confirm, then press <Enter>.



Important:

The power button will not function once a keyboard password has been set in the "KB Power On Password" field. To power-on the system, you must type the password then press <Enter>.

<i>Hot Key</i>	When this option is selected, the “KB Power On Hot Key” field will appear. Move the cursor to this field to select a function key you would like to use to power-on the system. The options are Ctrl-F1 to Ctrl-F12.
<i>Mouse Left</i>	When this option is selected, double-click the left button of the mouse to power-on the system.
<i>Mouse Right</i>	When this option is selected, double-click the right button of the mouse to power-on the system.
<i>Any Key</i>	You can press any key to power-on the system.

3.1.9 Supervisor Password

If you want to protect your system and setup from unauthorized entry, set a supervisor's password with the “System” option selected in the BIOS Features Setup. If you want to protect access to setup only, but not your system, set a supervisor's password with the “Setup” option selected in the BIOS Features Setup. You will not be prompted for a password when you cold boot the system.

Use the arrow keys to highlight the “Supervisor Password” option and press <Enter>. The message below will appear:

Enter Password:

Type in the password. You are limited to eight characters. When done, the message below will appear:

Confirm Password:

You are asked to verify the password. Type in exactly the same password. If you type in a wrong password, you will be prompted to enter the correct password again. To delete or disable the password function, highlight “Supervisor Password” and press <Enter>, instead of typing in a new password. Press the <Esc> key to return to the main menu.

3.1.10 User Password

If you want another user to have access only to your system but not to setup, set a user's password with the "System" option selected in the BIOS Features Setup. If you want a user to enter a password when trying to access setup, set a user's password with the "Setup" option selected in the BIOS Features Setup. Using user's password to enter Setup allows a user to access only the "User Password" option that appears on the main screen. Access to all other options is denied. To set, confirm, verify, disable or delete a user's password, follow the procedures described in the section "Supervisor Password". If you forget your password, refer to the procedure described in the same section.

3.1.11 IDE HDD Auto Detection

Use this option to detect the parameters for the hard disk drives installed in your system. These parameters will then be automatically entered into the "Standard CMOS Setup". The IDE HDD Auto Detection screen displays the following categories of information: Size, Cylinders, Heads, Precomp, LandZone, Sectors and Mode.

ROM PCI/ISA BIOS
CMOS SETUP UTILITY
AWARD SOFTWARE, INC.

HARD DISKS	TYPE	SIZE	CYLS	HEAD	RECOMP	LANDZ	SECTOR	MODE
Primary Master:								
Select Primary Master Option (N=Skip): N								
OPTIONS	SIZE	CYLS	HEAD	RECOMP	LANDZ	SECTOR	MODE	
2 (Y)	853	827	32	0	1653	63	LBA	
1	853	1654	16	65535	1653	63	Normal	
3	853	827	32	65536	1653	63	Large	
Note: Some OS (like SCO-UNIX) must be "NORMAL" for installation								
ESC: Skip								

The settings on the screen are for reference only. Your version may not be identical to this one.

For hard drives larger than 528MB, you would typically select the LBA type. Certain operating systems require that you select Normal or Large. Please check your operating system's manual or Help desk on which one to select.

3.1.12 Save & Exit Setup

When all the changes have been made, highlight "Save & Exit Setup" and press <Enter>. The message below will appear:

Save to CMOS and Exit (Y/N)? N

Type "Y" and press <Enter>. The modifications you have made will be written into the CMOS memory, and the system will reboot. You will once again see the initial diagnostics on the screen. If you wish to make additional changes to the setup, press <Ctrl> <Alt> <Esc> simultaneously or after memory testing is done.

3.1.13 Exit Without Saving

When you do not want to save the changes you have made, highlight "Exit Without Saving" and press <Enter>. The message below will appear:

Quit Without Saving (Y/N)? N

Type "Y" and press <Enter>. The system will reboot and you will once again see the initial diagnostics on the screen. If you wish to make any changes to the setup, press <Ctrl> <Alt> <Esc> simultaneously or after memory testing is done.

Chapter 4 - Supported Softwares

4.1 Desktop Management Interface (DMI)

The system board comes with a DMI built into the BIOS. DMI, along with the appropriately networked software, is designed to make inventory, maintenance and troubleshooting of computer systems easier. With DMI, a network administrator or MIS engineer can remotely access some information about a particular computer system without physically going to it. Quite often a service call may be unnecessary as the problem can be solved remotely.

The DMI utility in the BIOS automatically records various information about your system configuration. Information about the type and speed of CPU, type and amount of memory for each memory slot, BIOS revision level, types of add-in PCI boards and components, certain revision numbers of hardware installed, etc. are automatically detected and stored in the DMI pool, which is a part of the system board's Plug and Play BIOS. Additional information, such as ISA based peripherals, which may not be automatically detected, can be manually recorded in the DMI pool by using the Add DMI menu. The DMI pool data is then verified or updated whenever the system hardware or setup is altered.

4.1.1 Running the DMI Utility

To run the DMI utility, type: DMICFG.EXE. You can download this utility from <http://www.dfiweb.com> - BIOS & DRIVERS section or <ftp.dfiusa.com> - /pub/DMI directory.

The DMI utility must run in real mode with at least 180K of base memory. Memory managers like HIMEM.SYS (required by Windows) must not be installed. You may do this by using one of the 3 methods listed below.

1. Boot up from a system diskette without the AUTOEXEC.BAT and CONFIG.SYS files,
2. "REM" HIMEM.SYS in the CONFIG.SYS, or
3. Press <F5> during bootup to bypass your AUTOEXEC.BAT and CONFIG.SYS files.

4.1.2 Using the DMI Utility

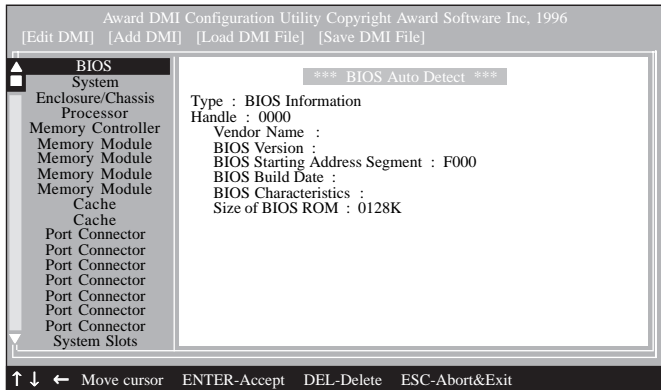

The four menus located on top of the DMI Configuration Utility screen are Edit DMI, Add DMI, Load DMI File and Save DMI File. Use the ← or → (left or right) arrow keys to select a menu from the Menu bar.

On the left side of the screen is a list of the system configuration items. Use the ↑ or ↓ (up or down) arrow keys to select an item.

The commands at the bottom of the screen will allow you to navigate through the various setup menus.

Edit DMI

1. Use the ← or → arrow keys to select the Edit DMI menu.
2. Highlight the item on the left screen that you would like to edit by using the ↑ or ↓ arrow keys, then press <Enter>.
3. The cursor will move to the screen you select allowing you to edit information. The screen will also display the auto-detected information.
4. Press <F10> to update the edited information into the flash ROM.

Add DMI

1. Use the ← or → arrow keys to select the Add DMI menu.
2. Highlight the item on the left screen that you would like to add by using the ↑ or ↓ arrow keys, then press <Enter>.
3. The cursor will move to the screen you select allowing you to enter information about the added item.
4. Press <F10> to save information into the flash ROM.

To view information about the added items, go to the Edit DMI menu.

Load DMI File

1. Use the ← or → arrow keys to select the Load DMI File menu.
2. The following message will appear:
Press [Enter] to select DMI file for load
Press <Enter>.
3. The DMI files will appear on the screen. Select the file you would like to load and press <Enter>.
4. The following message will appear:

Do you want to execute? (Y/N)

Type <Y>. All previous DMI structures will be destroyed and the new file will be saved into the flash ROM.

Save DMI File

1. Use the ← or → arrow keys to select the Save DMI File menu.
2. The following message will appear:
Press [Enter] to select DMI file for save
Press <Enter>.
3. Enter the directory and filename under which you would like the DMI file saved.

4.2 System Health Monitor Utility

The system board comes with a System Health Monitor utility contained in the provided CD. This utility shows the current temperature of the processor, power voltages, and processor/chassis fan speed.

The utility also allows you to manually set the range of the processor's temperature, power voltages, and processor/chassis fan speed. If the settings/values are over or under the set range, an error message will pop-up and an alarm will sound. There are three types of sound for the three different failure alarms (temperature, voltage and fan). Refer to the Chipset Features Setup (Chapter 3) section for details.

When you hear a failure alarm, you must power off your computer and check the following: processor fan/heatsink, chassis fan and power supply. We recommend that you use the "Default Setting" which is the ideal setting that would keep the system in good working condition.

Genesys Logic System Health Monitor Rev.A (for VIA)

The time interval for monitoring the system: Polling Interval: 4 Seconds

Temperature: CPU Over-Heat Temperature: 75, CPU Hysterisis Temperature: 70, CPU Temperature: 29. Units: Celsius (selected) or Fahrenheit.

Output voltage limit: Voltage (V) table below.

CPU/Chassis fan speed limit: Fan (RPM) table below.

Alarm when:

- CPU Over Heat
- 3.3V Abnormal
- 12V Abnormal
- 5V Abnormal
- 1.5V Abnormal
- CPU Fan Abnormal
- Chassis Fan Abnormal

When enabled, this screen will minimize and display a histogram icon after boot-up.

These items when enabled will alert you in case of detected failure.

Voltage (V)	High Limit	Current Voltage	Low Limit
3.3V	3.63	3.29	2.97
12.0V	13.20	11.98	10.80
5.0V	5.50	5.00	4.50
1.5V	1.65	1.54	1.35

Fan (RPM)	Low Limit	Current Speed:
CPU Fan	2000	4285
Chassis Fan	1000	3478

**Important:**

Once this utility is installed, the system will ignore the settings in the "System Health Monitor" field of the Chipset Features Setup. If you are using Windows® 95 or Windows NT® 4.0, you may select between using the utility and the Chipset Features Setup. For other operating systems, you may only use the Chipset Features Setup.

4.2.1 Installing the Utility

Insert the CD that came with the system board into a CD-ROM drive. Run SETUP.EXE of the System Health Monitor utility. After completing installation, you will find this utility in "StartUp" under "Programs" of Windows® 95/NT4.0. Please refer to the "Readme" file for details on using the utility.

4.3 Drivers

The system board package comes with drivers for different operating systems contained in the provided CD. To install the drivers, please refer to the "Readme" file contained in the provided CD.

If you are running Windows® 95 (Win95, Win95+, Win95 OSR1: Windows 95 OEM Service Release 1, Win95 OSR2: Windows 95 OEM Service Release 2.0 or Win95 OSR2.1: Windows 95 OEM Service Release 2.0 plus USB Supplement), you need to run a utility. Please refer to the "Readme" file contained in the provided CD.

All steps or procedures to install software drivers are subject to change without notice as the softwares are occasionally updated. Please refer to the readme files for the latest information.

Appendix A - System Error Message

When the BIOS encounters an error that requires the user to correct something, either a beep code will sound or a message will be displayed in a box in the middle of the screen and the message, PRESS F1 TO CONTINUE, CTRL-ALT-ESC or DEL TO ENTER SETUP, will be shown in the information box at the bottom. Enter Setup to correct the error.

A.1 POST Beep

There are two kinds of beep codes in the BIOS. One code indicates that a video error has occurred and the BIOS cannot initialize the video screen to display any additional information. This beep code consists of a single long beep followed by three short beeps. The other code indicates that a DRAM error has occurred. This beep code consists of a single long beep.

A.2 Error Messages

One or more of the following messages may be displayed if the BIOS detects an error during the POST. This list indicates the error messages for all Awards BIOSes:

CMOS BATTERY HAS FAILED

The CMOS battery is no longer functional. It should be replaced.



Caution:

Danger of explosion if battery incorrectly replaced. Replace only with the same or equivalent type recommended by the manufacturer. Dispose of used batteries according to the battery manufacturer's instructions.

CMOS CHECKSUM ERROR

Checksum of CMOS is incorrect. This can indicate that CMOS has become corrupt. This error may have been caused by a weak battery. Check the battery and replace if necessary.

DISPLAY SWITCH IS SET INCORRECTLY

The display switch on the motherboard can be set to either monochrome or color. This indicates the switch is set to a different

setting than indicated in Setup. Determine which setting is correct, either turn off the system and change the jumper or enter Setup and change the VIDEO selection.

FLOPPY DISK(S) fail (80)

Unable to reset floppy subsystem.

FLOPPY DISK(S) fail (40)

Floppy type mismatch.

Hard Disk(s) fail (80)

HDD reset failed.

Hard Disk(s) fail (40)

HDD controller diagnostics failed.

Hard Disk(s) fail (20)

HDD initialization error.

Hard Disk(s) fail (10)

Unable to recalibrate fixed disk.

Hard Disk(s) fail (08)

Sector Verify failed.

Keyboard is locked out - Unlock the key

The BIOS detects that the keyboard is locked. Keyboard controller is pulled low.

Keyboard error or no keyboard present

Cannot initialize the keyboard. Make sure the keyboard is attached correctly and no keys are being pressed during the boot.

Manufacturing POST loop

System will repeat POST procedure infinitely while the keyboard controller is pull low. This is also used for the M/B burn in test at the factory.

BIOS ROM checksum error - System halted

The checksum of ROM address F0000H-FFFFFH is bad.

Memory test fail

The BIOS reports memory test fail if the memory has error(s).

Appendix B - Troubleshooting

B.1 Troubleshooting Checklist

This chapter of the manual is designed to help you with problems that you may encounter with your personal computer. To efficiently troubleshoot your system, treat each problem individually. This is to ensure an accurate diagnosis of the problem in case a problem has multiple causes.

Some of the most common things to check when you encounter problems while using your system are listed below.

1. The power switch of each peripheral device is turned on.
2. All cables and power cords are tightly connected.
3. The electrical outlet to which your peripheral devices are connected is working. Test the outlet by plugging in a lamp or other electrical device.
4. The monitor is turned on.
5. The display's brightness and contrast controls are adjusted properly.
6. All add-in boards in the expansion slots are seated securely.
7. Any add-in board you have installed is designed for your system and is set up correctly.

Monitor/Display

If the display screen remains dark after the system is turned on:

1. Make sure that the monitor's power switch is on.
2. Check that one end of the monitor's power cord is properly attached to the monitor and the other end is plugged into a working AC outlet. If necessary, try another outlet.
3. Check that the video input cable is properly attached to the monitor and the system's display adapter.
4. Adjust the brightness of the display by turning the monitor's brightness control knob.

The picture seems to be constantly moving.

1. The monitor has lost its vertical sync. Adjust the monitor's vertical sync.
2. Move away any objects, such as another monitor or fan, that may be creating a magnetic field around the display.
3. Make sure your video card's output frequencies are supported by this monitor.

The screen seems to be constantly wavering.

1. If the monitor is close to another monitor, the adjacent monitor may need to be turned off. Fluorescent lights adjacent to the monitor may also cause screen wavering.

Power Supply

When the computer is turned on, nothing happens.

1. Check that one end of the AC power cord is plugged into a live outlet and the other end properly plugged into the back of the system.
2. Make sure that the voltage selection switch on the back panel is set for the correct type of voltage you are using.
3. The power cord may have a "short" or "open". Inspect the cord and install a new one if necessary.

Floppy Drive

The computer cannot access the floppy drive.

1. The floppy diskette may not be formatted. Format the diskette and try again.
2. The diskette may be write-protected. Use a diskette that is not write-protected.
3. You may be writing to the wrong drive. Check the path statement to make sure you are writing to the targeted drive.
4. There is not enough space left on the diskette. Use another diskette with adequate storage space.

Hard Drive

Hard disk failure.

1. Make sure the correct drive type for the hard disk drive has been entered in the BIOS.
2. If the system is configured with two hard drives, make sure the bootable (first) hard drive is configured as Master and the second hard drive is configured as Slave. The master hard drive must have an active/bootable partition.

Excessively long formatting period.

1. If your hard drive takes an excessively long period of time to format, it is likely a cable connection problem. However, if your hard drive has a large capacity, it will take a longer time to format.

Parallel Port

The parallel printer doesn't respond when you try to print.

1. Make sure that your printer is turned on and that the printer is on-line.
2. Make sure your software is configured for the right type of printer attached.
3. Verify that the onboard LPT port's I/O address and IRQ settings are configured correctly.
4. Verify that the attached device works by attaching it to a parallel port that is working and configured correctly. If it works, the printer can be assumed to be in good condition. If the printer remains inoperative, replace the printer cable and try again.

Serial Port

The serial device (modem, printer) doesn't output anything or is outputting garbled characters.

1. Make sure that the serial device's power is turned on and that the device is on-line.
2. Verify that the device is plugged into the correct serial port on the rear of the computer.
3. Verify that the attached serial device works by attaching it to a serial port that is working and configured correctly. If the serial device does not work, either the cable or the serial device has a problem. If the serial device works, the problem may be due to the onboard I/O or the address setting.
4. Make sure the COM settings and I/O address are configured correctly.

Keyboard

Nothing happens when a key on the keyboard was pressed.

1. Make sure the keyboard is properly connected.
2. Make sure there are no objects resting on the keyboard and that no keys are pressed during the booting process.

System Board

1. Make sure the add-in card is seated securely in the expansion slot. If the add-in card is loose, power off the system, re-install the card and power up the system.
2. Check the jumper settings to ensure that the jumpers are properly set.
3. Verify that all memory modules are seated securely into the memory sockets.
4. Make sure the SIMMs are in the correct locations.
5. If the board fails to function, place the board on a flat surface and seat all socketed components. Gently press each component into the socket.
6. If you made changes to the BIOS settings, re-enter setup and load the BIOS defaults.