



M1646

Athlon K7™ Super Northbridge Internal 4XAGP, PCI and SDR/DDR Memory Controller DX7 Integrated Graphics

Product Brief

INTRODUCTION

The M1646 is ALi and Trident's new generation of PCI Northbridge chip supporting all AMD Slot-A/Socket A Athlon K7™ Processors. The M1646 is a single chip solution which interfaces to a 200/266MHz double data rate front side bus (FSB), and provides a high performance memory interface for 66/100/133 SDR and 133/200/266 DDR memory devices. The PC-266 DDR memory enables 2.1 GB/s peak bandwidth between the system memory and Northbridge to boost system performance to the next higher level.

FEATURES

Processor Support

- Supports all AMD Slot-A/Socket A Athlon K7™, processors.
- Host bus frequency can be either 100MHz or 133 MHz double data rate.
- 64-bit data bus and 32-bit addressing
- Optimum buffering architecture design for CPU to memory, internal AGP and PCI read/write
- Supports both S2K bus open-drain and push pull mode
- Supports notebook features, including FID change special cycles
- Supports 8 outstanding processor commands
- Supports 8 outstanding system probe commands
- Flexible configured to support back to back read transfer in 1QW or 2QW
- Supports back to back write transfers
- Optimized processor command scheduling and reordering
- Support synchronous / asynchronous clock mode between processor and memory interface with optimized latency

Memory Support

- Supports SDRAM / DDR at 66, 100, 133MHz
- Supports symmetrical and asymmetrical SDRAM / DDR addressing
- Supports 4, 16, 64, 128, 256, 512Mbit SDRAM / DDR
- Maximum memory size : 3 GB
- Support 6 memory rows with per byte access on each row
- Supports memory shadowing
- x-1-1-1-1-1-1 back-to-back page hit
- CAS before RAS and self refresh for SDRAM
- Pipelined SDRAM / DDR cycle control with hidden pre-charge
- Dynamic switching CKE algorithm
- Supports LVTTTL / SSTL2 signal level

PCI Bus Support

- Supports synchronous / asynchronous clock mode between the processor bus and the PCI bus
- 32-bit Address / Data PCI bus using PCI bus driver technology

On the graphics side, the M1646 integrates the DirectX 7 (DX7) ready graphic core (Cyberblade XP) from Trident Microsystems. The Cyberblade XP has dual pixel pipes and a hardware transform and lighting (T&L) unit which provide enough rendering power to satisfy high end graphics requirements. ALi also manufactures a series of feature-rich, highly integrated Southbridge devices (M1535 and M1535+) which seamlessly work with the M1646 to create a complete, flexible and cost-effective solution for notebook designers. The M1646 also incorporates ALi's proven power management support, which is crucial for mobile applications.

- Supports up to 6 PCI masters excluding the M1646 and PCI-to-ISA bridge
- Parity protection on all PCI bus signals
- Fully supports PCI Configuration Space Enable (CSE) protocol
- Fully compliant with PCI Rev. 2.2
- Supports delayed transaction
- Dynamic memory prefetch algorithm and programmable post write flush algorithm
- Data Collection/Write assembly of line bursts
- Supports concurrent PCI bus burst transfer at zero wait-states
- 133 MB/sec data streaming for PCI bus to SDRAM / DDR access with minimum latency

Power Management

- Supports ACPI 1.0b and Legacy green
- Supports PCI Mobile CLKRUN#
- Supports AGP Mobile BUSY# / STOP#
- Internally dynamic clock stop

Trident Cyberblade XP Graphic Core

- Advanced Blade™ Dual-Pixel, Single-pass 3D and 2D rendering engine
- Low power (2.1 watts maximum)
- 128-bit bus interface to external SGRAM/SDRAM
- Support of Microsoft DirectX 7.0 with cubic mapping
- Dual Panel interface to both external LVDS & TMDS
- Digital interface to external TV encoder
- DVD hardware assist with Motion Compensation (MC) and Inverse Discrete Cosine Transform (IDCT)
- TrueVideo with Advanced Video De-interlacing
- Linear display memory addressing up to 4GB memory
- 256 Raster Operations (ROPs) up to 32-bit True Color
- 270 MHz built-in RAMDAC™ and frequency synthesizer
- Two four-color hardware cursor and pop-up icons
- PC2001 Compliant

High Performance DirectX 7.0 3D Engine

- Dual-Pixel, Single-Pass 3D rendering engine
- Supports all DirectX 7.0 feature set and vertex format
- Special hardware support for DirectX 7.0 cubic mapping and bump mapping
- Optimized 32-bit IEEE floating point setup engine
- 128-bit texture engine with 4KB texture cache
- Simultaneous diffuse, Specular lighting, Gouraud Shading, Z-buffering and fog with no performance penalty
- Perspective correct mip-mapped texturing
- Bilinear, trilinear and Anisotropic filtering
- Texture compression and tiling
- Point sampled or bi-linear filtered texture maps are palletized and/or perspective corrected
- Chroma key, Alpha blending and color key operations
- OpenGL compliant

Enhanced Bus Interface

- 66/133/266 MHz AGP-1X/2X/4X with sideband
- DMA mastering with Scatter Gather
- Execute mode for Direct Textures, Video and DVD

MPEG2/DVD Hardware Assist Playback

- THAMA™ (Trident Hardware-Assisted MPEG-2 Acceleration) architecture enables full DVD player support with AC3 and subpicture support
- 30fps playback of 9.8Mbps VBR MPEG-2 video with 40-60% CPU headroom for other applications
- Hardware Alpha blending for subpicture
- Advanced error recovery & concealment for handling poor quality video clips
- Programmable multi-tap filtering
- Supports DVD v1.0 and VCD v2.0
- Pan and Scan support

TrueVideo® Accelerator

- TrueVideo® provides horizontal and vertical interpolation with proprietary edge recovery scaling
- Dual apertures for simultaneous access to graphics and video display memory areas
- Dual color space converters (CSC)
- Field rendering for interlace support on NI display
- Accelerates YUV planar format

Motion Video Capture Port

- ZV port accepting RGB, YUV 4:2:2, and YUV planar 4:2:0 formats
- VIP bus 2.0 support
- CCIR 656/CCIR 601
- VBI (Intercast) interface can separate vertical blank interval data for transmission to CPU using PCI Bus Mastering

Advanced Mobile Power Management

- Low power cell design
- 8 GPIOs, suspend and standby modes
- Internal clock gating on each functional block
- PCIPM (H/W PCI initiated)
- AGP Busy#/Stop# and PCI Clock Run#
- ACPI and DPMS support

Multiple/Simultaneous Display

- Different/same images with independent refresh rates on separate displays(panels, CRT or TV)
- Vertical/horizontal virtual desktop
- Microsoft® Windows 98 Multi-Head and Multi-Monitor support
- Supports up to 3 displays

Advanced Flat Panel Support

- Frame rate modulation and spatial dithering for increased color depth
- Gamma correction for color enhancement
- Auto expansion and centering
- 16/24-bit interface to TFT panel
- Straight or double pixel/clock interface for up to 1280x1024 SXGA TFT panels
- External Spread Spectrum support for significantly reduced EMI at high frequency clock rates

Integrated LVDS support

- Integrated high-speed single channel LVDS for substantial power, space and EMI reduction
- Wide Frequency range of 32-112MHz MHz suited for SVGA, XGA and SXGA panels
- 392Mbps/channel throughput with 28:4 bits Data Channel Compression
- Compatible with receivers from Thine, National Semiconductor and Texas Instrument

CRT

- Supports high quality CRT display up to 1600x1200
- VESA™ DDC2B compliance

TV Presentation/ Game Ready

Direct interface to Trident's TVXpress digital TV encoder offering

- Better text quality
- Macrovision 7.0x compliant
- Low cost, high quality PC to TV output
- NTSC and PAL outputs
- Composite, S-Video and SCART interface Support

Packaging

- 555 balls 35x35mm BGA package

M1646 Architecture

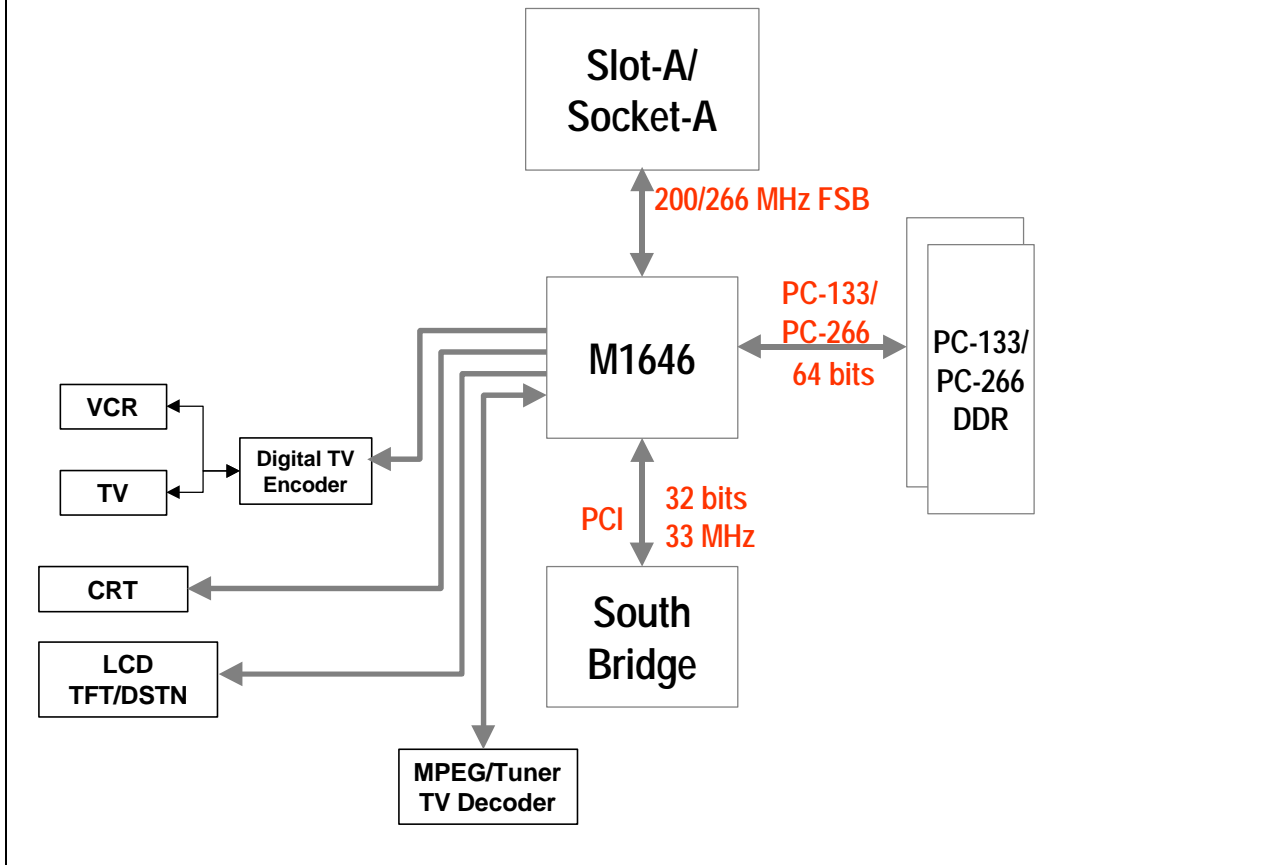

For more information contact:

Acer Laboratories Inc., USA

525 E. Brokaw Road, San Jose, CA 95112
 Tel: 408-544-3100, Fax: 408-544-3135
 www.acerlabs.com

Trident Technologies Inc.

18F, no.202 Sec.2, Yen Ping N. Rd., Taipei, Taiwan
 Tel: 886-2-2550-6616, Fax: 886-2-2550-3901
 www.trident.com.tw

ALi is a registered trademark of Acer Laboratories Inc. Other trademarks are property of their respective companies.