

PAM-0070S

High Performance
Pentium PCI ATX Mainboard
User's Guide



Edition 1.20
©1997 DTK Computer, Inc.

P/N: 155100-8452



WARNING

For the system to operate normally, please make sure JP8 of the mainboard is set as below. Refer to Fig. 3 in this manual for the location JP8.

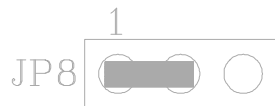

If JP8 is shorted to 2-3, no CMOS data can be retained.

CAUTION

The motherboard is an electrostatic sensitive device. Don't open or handle except at a static-free workstation.

Windows, MS-DOS, and MS Word are trademarks of Microsoft Corporation.

Novell, Netware are trademarks of Novell, Inc.

PC, AT, PC-DOS, OS/2 and Presentation Manager are trademarks of IBM Corporation.

Pentium is registered trademark of Intel Corp.

UNIX is the trademark of AT&T.

All other brand and product names are trademarks or registered trademarks of their respective companies.

The information presented in this publication has been carefully checked for reliability; however, no responsibility is assumed for inaccuracies, whereas, specification is subjected to change without notice.

CONTENTS

CHAPTER 1	INTRODUCTION	1
CHAPTER 2	JUMPER SETTINGS	5
2.1	JUMPERS PRESENTATION	5
2.2	CPU TYPE	5
2.2.1	INTEL PENTIUM CPU	5
2.2.2	INTEL PENTIUM w/ MMX™ TECH (P55C) CPU	6
2.2.3	AMD-K6 CPU	6
2.2.4	AMD-K5 CPU	7
2.2.5	CYRIX 6x86 CPU	7
2.2.6	CYRIX 6x86L CPU	8
2.2.7	CYRIX 6x86MX CPU	8
2.3	GRAPHICAL DESCRIPTION OF JUMPER SETTINGS	9
2.4	CPU VOLTAGE	10
2.4.1	CPU VOLTAGE AUTO SELECTION	10
2.4.2	CPU VOLTAGE BIOS SELECTION	10
2.4.3	CPU VOLTAGE MANUAL SELECTION	11
2.5	CPU EXTERNAL (BUS) FREQUENCY SELECTION (SW1-6,7,8)	11
2.6	CPU TO BUS FREQUENCY RATION (SW1-3,4,5)	11
2.7	JP8 - CLEAR CMOS DATA	13
2.8	JP1 - VOLTAGE SELECTION FOR SYSTEM ROM	14
2.9	JP3 - ONBOARD AUDIO SELECT	14
2.10	JP4, 5 - ONBOARD VGA SELECT	15
2.11	JP11 - INTERNAL MODEM RING-IN CONNECTOR	15
2.12	RESERVED JUMPERS	15
2.13	MEMORY CONFIGURATION	16
CHAPTER 3	CONNECTOR CONFIGURATION	17
3.1	J1 - MULTIPLE FUNCTION JUMPER	18
3.2	J2 - WAVETABLE EXPANSION CONNECTOR	18
3.3	J3 - CD-ROM AUDIO CONNECTOR (MISUMI/PANASONIC)	18
3.4	J4 - CD-ROM AUDIO CONNECTOR (SONY)	19
3.5	J8 - IrDA/FAST IR CONNECTOR	19
3.6	J17 - CPU FAN CONNECTOR	19
3.7	J16 - ATX POWER CONNECTOR	20
3.8	J5 - FLOPPY DRIVE CONNECTOR	22
3.9	J6, J7 - PRIMARY/SECONDARY IDE CONNECTORS	22
3.10	J11 - SERIAL PORT COM2 CONNECTOR	22
3.11	J10 - FEATURE CONNECTOR	22
3.12	PS/2 KEYBOARD CONNECTOR	22
3.13	PS/2 MOUSE CONNECTOR	23
3.14	UNIVERSAL SERIAL BUS PORTS 0 & 1	23
3.15	PARALLEL PORT CONNECTOR	23

3.16	SERIAL PORT COM1	23
3.17	AUDIO PORT CONNECTOR	23
CHAPTER 4	AWARD BIOS SETUP GUIDE	25
4.1	AWARD BIOS SETUP	25
4.2	STANDARD CMOS SETUP	27
4.3	BIOS FEATURES SETUP	28
4.4	CHIPSET FEATURES SETUP	30
4.5	POWER MANAGEMENT SETUP MENU	32
4.6	PCI CONFIGURATION	34
4.7	INTEGRATED PERIPHERALS SETUP MENU	35
4.8	LOAD SETUP DEFAULTS MENU	37
4.9	SUPERVISOR PASSWORD	37
4.10	USER PASSWORD	38
4.11	IDE HDD AUTO DETECTION	38
4.12	SCSI HARD DISK INSTALLATION	39
4.13	SAVE & EXIT SETUP MENU	39
4.14	EXIT WITHOUT SAVING MENU	39
CHAPTER 5	SOFTWARE INSTALLATION	41
5.1	PCI IDE DRIVER INSTALLATION	41
5.2	PCI VGA DRIVER INSTALLATION	41
5.3	SOUND DRIVER INSTALLATION	41
5.4	THE AUDIORACK32 FOR WIN95	42
5.4.1	INTRODUCTION	42
5.4.2	INSTALLING THE <i>AudioRack32</i>	42
5.4.3	UNINSTALLING THE <i>AudioRack32</i>	45
5.5	XING MPEG PLAYER (OPTIONAL)	45
CHAPTER 6	AWARD ZERO-VOLT DATA-SUSPEND UTILITY	47
6.1	INTRODUCTION	47
6.2	PREPARATION	47
6.3	RUNNING THE PROGRAM	48
6.3.1	INSTALLATION	48
6.3.2	SAVING SESSION DATA	50
6.4	PROGRAM FUNCTIONS	51
6.4.1	USAGE	51
6.4.2	REFORMATTING THE STORAGE PARTITION	52
6.4.3	DELETING THE STORAGE FILE OR PARTITION	52
CHAPTER 7	FLASH AND DMI UTILITY	53
7.1	AWARD FLASH UTILITY	53
7.2	DESKTOP MANAGEMENT INTERFACE (DMI) OVERVIEW	55
APPENDIX A	QUICK GUIDE	59

CHAPTER 1

INTRODUCTION

Preface

The motherboard is a full ATX form factor high performance all in one mainboard. It is developed around the pentium microprocessor with 64 bit access to data transfer and MMX technology. It includes SiS 5598 PCI/ISA System Chipset with Graphics/Video accelerate function build-in, Winbond W83877F super I/O chip, ESS 1869 Sound System.

Features

Processor

- Intel Pentium/MMX, Cyrix 6x86/6x86L/6x86MX and AMD K5/K6 CPU.
- The mainboard can run with following speeds:
90, 100, 110, 120, 133, 150, 166, 200, 233 and 266 MHz

Chipset

- SiS 5598 PCI, Memory and VGA Controller
- Winbond W83877F Super I/O Controller
- ESS 1869 Audio-Drive Sound Controller

Cache Size

- Built in 512KB Synchronised Pipelined Burst Mode SRAM to achieve the high Pentium system performance.

Main Memory

- Support Mixed Memory Technologies: Extend Data Output (EDO), Standard Page Mode (SPM), Fast Page Mode (FPM) and Synchronous DRAM (SDRAM) can work together.
- Memory configurations from 8MB to 384MB are possible using combination of 1M*32 to 8*32 SIMM module (32 bit no-parity 72-pin SIMM module) and 2M*32 to 8M*32 SDRAM DIMM module.
- DIMM socket for SDRAM (3.3V unbuffered).
- 32 bit DRAM system supported - one piece of SIMM can start up the system.

Graphics Controller

- Built-in an enhanced 64-bit BITBLT graphics engine with VGA feature connector on board.
- PCI 2.1 compliance, and PCI multimedia design Rev 1.0 support.
- Support DCI Drivers and Direct Draw Drivers.

Multi I/O

- On board Multi-I/O supports two serial, one parallel ports and floppy drive controller.
- Serial ports are 16550 Fast UART compatible.
- Parallel port has EPP and ECP capabilities.
- PS/2 keyboard and PS/2 mouse connector is provided.
- IrDA or Fast IR is provided.
- Two standard USB connectors are provided.

Chapter 1

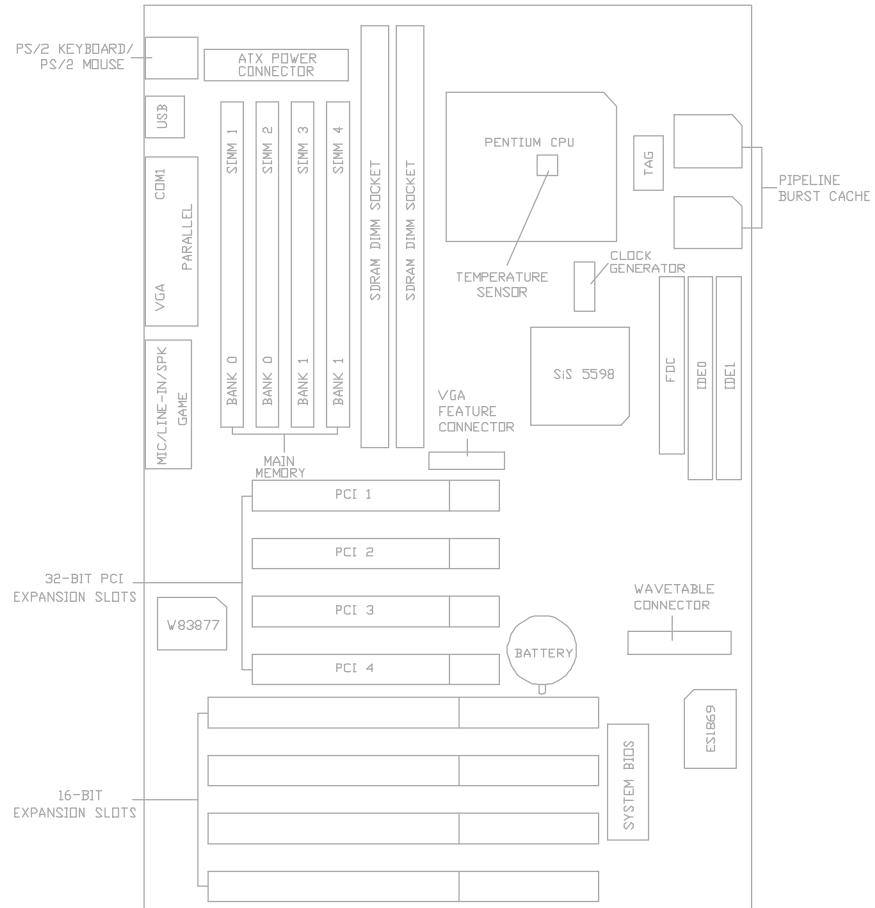

Fig. 1 Key Components of the Mainboard

PCI IDE

- On board supports PCI Master IDE Controller, two connectors support up to four IDE devices such as HDD, CD ROM drive and Tape Back-up drives LS-120, etc.
- PCI Master IDE controller supports PIO Mode 3 and 4 devices, I/O data transfer rate can be up to 17Mb/s.
- Ultra DMA Mode supported. Transfer rate can be up to 33MB/s.

Sound Controller

- Compatible with all major PC sound standards, including Sound Blaster™ Pro, MPU-401 and Windows Sound System™.
- Plug-and-Play support for Audio, Joystick, FM Controller, MPU-401.
- Wave Audio support sample rates from 4KHz to 44KHz.
- Full-duplex monophonic mode, half-duplex stereo mode.
- 3D stereo sound effect supported.
- Optional wavetable connector is provided.

System BIOS

- Award BIOS (256KB Flash EPROM).

Slots

- Four PCI slots
- Four ISA slots

Form Factor

- 304mm (W) x 210mm (L) 4 Layer

Environment

Working Specifications

Actual Field MTBF (hours)	104,515 hours
Preventive Maintenance	Not Required

Environmental Limits

	Operating	Non-operating
Temperature	0 to 50 degree Celsius	-10 to 65 Degree Celsius
Relative Humidity (without condensation)	8 to 85%	5 to 95%
Altitude	10,000ft	40,000ft
Vibration	1,000Hz	
Electricity	4.75 ~ 5.25V	

CHAPTER 2

JUMPER SETTINGS

2.1 JUMPERS PRESENTATION

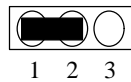

Pins 1 and 2 are shorted with a jumper cap.

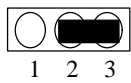

Pins 2 and 3 are shorted with a jumper cap.



The jumper is shorted when the jumper cap is placed over the two pins of the jumper.



The jumper is open when the jumper cap is removed from jumper.

2.2 CPU TYPE

2.2.1 INTEL PENTIUM CPU

The pentium processors have different operation voltage. In order to using the CPU Voltage correctly, the following is the marking for identify the CPU type.



**Fig. 2a CPU Description
(Bottom Side)**

Description :

X = Voltage Specification (S or V)

S = Standard Voltage (3.4V)

V = VRE 3.4 - 3.6V (3.5V)

Z = Dual Processing Support (S or U)

S = Support DP/MP/UP

U = Not tested to support DP

Y = Timing Specification (S or M)

S = Standard EDS timings

M = Min Valid Delay Spec.

2.2.2 INTEL PENTIUM w/ MMX[®] TECH (P55C) CPU

The Intel Pentium w/ MMX[™] Tech (P55C) CPU is offered with dual voltage supply - 2.8V for core and 3.3V (I/O) interface. The following is the marking for identify the CPU type. (The following diagram is provided as an example only. It does not necessarily indicate a valid product marking.)

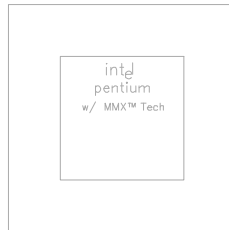

Fig. 2b CPU Description (Top Side)

2.2.3 AMD-K6 CPU

The AMD-K6 CPU family require dual voltage power for operation. The AMD-K6/166, 200 require a voltage of 2.9V core and 3.3V I/O. The AMD-K6/233 require a voltage of 3.2V core and 3.3V I/O. (The following diagram is provided as an example only. It does not necessarily indicate a valid product marking.)

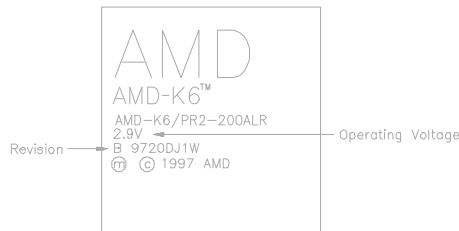

Fig. 2c CPU Description (Top Side)

Operating Voltage	I/O Voltage	Core Voltage
2.1V	3.3V	2.1V
2.9V	3.3V	2.9V
3.2V	3.3V	3.2V

2.2.4 AMD-K5 CPU

The AMD-K5 family CPU operates on different operation voltage depending on the CPU type. The operating voltage can be known through the marking on the surface of the CPU. (The following diagram is provided as an example only. It does not necessarily indicate a valid product marking.)

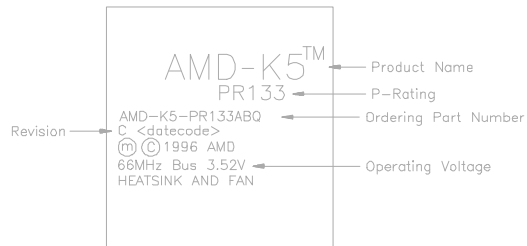

Fig. 2d CPU Description (Top Side)

2.2.5 CYRIX 6x86 CPU

The Cyrix 6x86 has different nominal voltage depends on different lot. Please refer to the CPU marking.

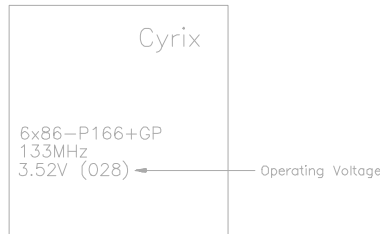

Fig. 2e CPU Description (Top Side)

Marketing	Recommended Nominal Voltage
3.3V or 3.52V	3.52V
028	3.52V
016	3.3V
Blank	3.52V

2.2.6 CYRIX 6x86L CPU

The Cyrix 6x86L has different I/O and core voltage. Please refer to the CPU marking.



**Fig. 2f CPU Description
(Top Side)**

2.2.7 CYRIX 6x86MX CPU

The Cyrix 6x86MX has different I/O and Core Voltage. Please refer to the CPU marking.



**Fig. 2g CPU Description
(Top Side)**

	I/O Voltage	Core Voltage
Cyrix 6x86MX	3.3V	2.9V
Cyrix 6x86L	3.3V	2.8V

2.3 GRAPHICAL DESCRIPTION OF JUMPER SETTINGS

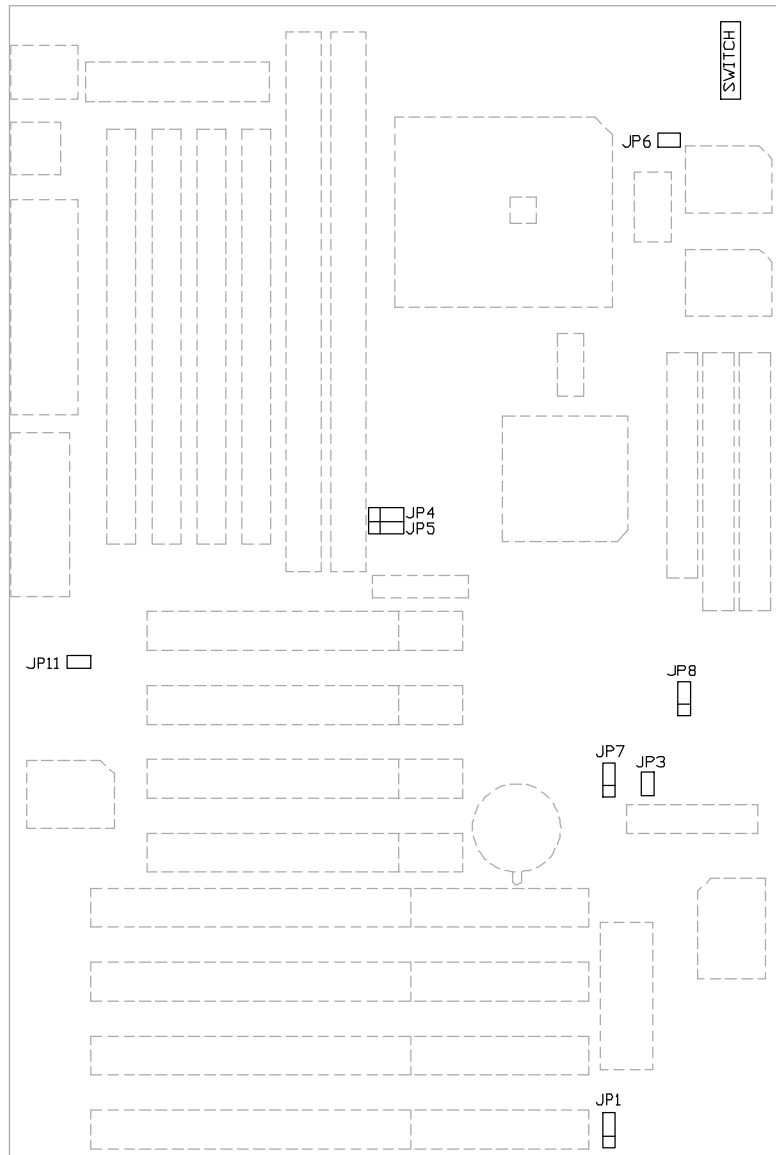

Fig. 3 Jumper Location of the mainboard

2.4 CPU VOLTAGE

2.4.1 CPU VOLTAGE AUTO SELECTION

The CPU voltage auto detection is developed on this motherboard. Set the SW1-1 and 2 at OFF position to enable the auto detection.

Note: SW1-1,2 should be set at OFF and BIOS “CPU core voltage” as Auto.

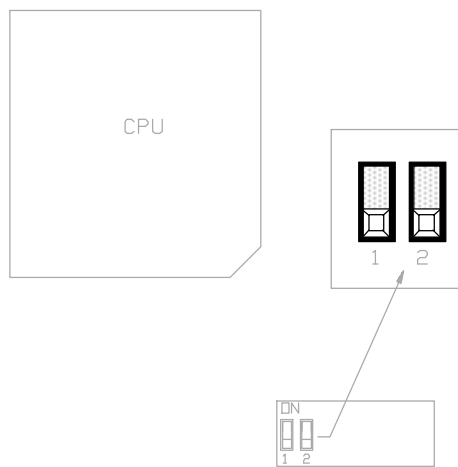

Fig. 4

2.4.2 CPU VOLTAGE BIOS SELECTION

The CPU Voltage can be selected through BIOS setup “CPU Core Voltage Selection”. It can be set as following table:

2.8	Intel MMX (P55C); 6x86L
2.9	AMD K6/166,200; 6x86MX
3.2	AMD K6/233, 266
3.3	Intel Pentium
3.52	6x86; AMD K5

Table 1

2.4.3 CPU VOLTAGE MANUAL SELECTION

The CPU Core Voltage can be selected by SW1-1, 2 when the BIOS “CPU Core Voltage” be set as Disabled.

SW1	CPU Type
	Intel Pentium w/MMX (P55C); 6x86L, 6x86MX; AMD K6-233, 266
	6x86; AMD K5
	AMD K6-166, 200; Intel Pentium (P54C)

Table 2

2.5 CPU EXTERNAL (BUS) FREQUENCY SELECTION (SW1-6,7,8)

These switches tell the clock generator what frequency to send to the CPU. The Bus clock times the Bus Ration equals the CPU’s Internal frequency.

2.6 CPU TO BUS FREQUENCY RATION (SW1-3,4,5)

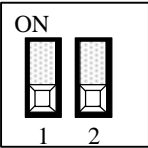
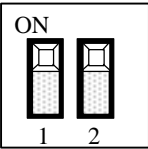
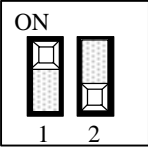
These jumpers set the frequency ration between the Internal frequency of the CPU and the External frequency (called the Bus clock) within the CPU. These must be set together with the above jumpers CPU External (Bus) Frequency Selection.

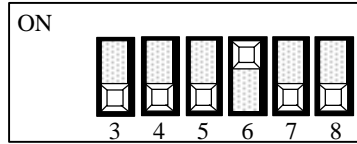

Fig 5

CPU Type	Freq.	Ratio	Bus Freq.	Ratio Setting			Bus Freq. Setting		
				SW1-3	SW1-4	SW1-5	SW1-6	SW1-7	SW1-8
Pentium	90MHz	1.5x	60MHz	OFF	OFF	OFF	ON	OFF	OFF
Pentium	100MHz	1.5x	66MHz	OFF	OFF	OFF	OFF	OFF	OFF
Pentium	120MHz	2.0x	60MHz	ON	OFF	OFF	ON	OFF	OFF
Pentium	133MHz	2.0x	66MHz	ON	OFF	OFF	OFF	OFF	OFF
Pentium	150MHz	2.5x	60MHz	ON	ON	OFF	ON	OFF	OFF
Pentium	166MHz	2.5x	66MHz	ON	ON	OFF	OFF	OFF	OFF
Pentium	200MHz	3.0x	66MHz	OFF	ON	OFF	OFF	OFF	OFF
Pentium w/MMX	166MHz	2.5x	66MHz	ON	ON	OFF	OFF	OFF	OFF
Pentium w/MMX	200MHz	3.0x	66MHz	OFF	ON	OFF	OFF	OFF	OFF
Pentium w/MMX	233MHz	3.5x	66MHz	OFF	OFF	OFF	OFF	OFF	OFF
AMD-K5-PR166	166MHz	2.5x	66MHz	ON	ON	OFF	OFF	OFF	OFF
AMD-K5-PR133	133MHz	2.0x	66MHz	ON	OFF	OFF	OFF	OFF	OFF
AMD-K5-PR120	120MHz	2.0x	60MHz	ON	OFF	OFF	ON	OFF	OFF
AMD-K6/266	266MHz	4.0x	66MHz	OFF	OFF	ON	OFF	OFF	OFF
AMD-K6/233	233MHz	3.5x	66MHz	OFF	OFF	OFF	OFF	OFF	OFF
AMD-K6/200	200MHz	3.0x	66MHz	OFF	ON	OFF	OFF	OFF	OFF
AMD-K6/166	166MHz	2.5x	66MHz	ON	ON	OFF	OFF	OFF	OFF
Cyrix 6x86MX-PR200	150MHz	2.0x	75MHz	ON	OFF	OFF	OFF	ON	OFF
Cyrix 6x86MX-PR166	150MHz	2.5x	60MHz	ON	ON	OFF	ON	OFF	OFF
Cyrix 6x86L-PR200	150MHz	2.0x	75MHz	ON	OFF	OFF	OFF	ON	OFF
Cyrix 6x86L-PR166	133MHz	2.0x	66MHz	ON	OFF	OFF	OFF	OFF	OFF
Cyrix 6x86L-PR150	120MHz	2.0x	60MHz	ON	OFF	OFF	ON	OFF	OFF

Table 3

2.7 JP8 - CLEAR CMOS DATA

JP8 is used to clear the content of the CMOS Data in the RTC (Build in SiS 5598 chip)

1. Normal Mode

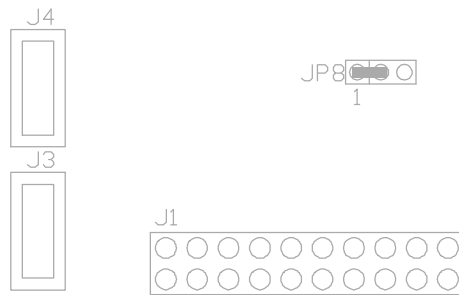

Fig. 6a

2. Reset Content of RTC

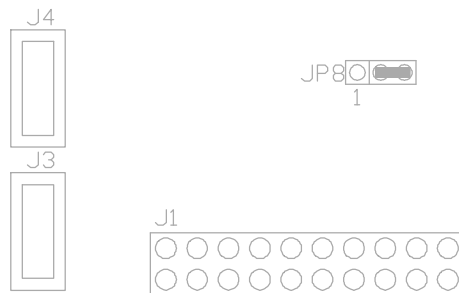

Fig. 6b

2.8 JP1 - VOLTAGE SELECTION FOR SYSTEM ROM

1. 5V Flash EPROM on System ROM

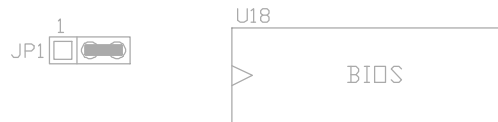

Fig. 7a

2. 12V Flash EPROM on System ROM

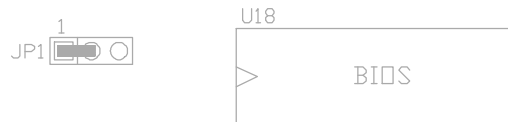

Fig. 7b

2.9 JP3 - ONBOARD AUDIO SELECT

JP3 is used to set the onboard Audio enabled or disabled.



JP3	Description
	Enable
	Disable

Table 4 :Onboard Audio Select

2.10 JP4, 5 - ONBOARD VGA SELECT

JP4 and JP5 is used to set the onboard VGA enabled or disabled.

		Description
	JP4 JP5	Enable
	JP4 JP5	Disable

Table 5 : Onboard VGA Select

2.11 JP11 - INTERNAL MODEM RING-IN CONNECTOR

JP11 is a 3 pin connector which is used to connect the Internal Modem's Ring-In signal to the mainboard. Thus, the mainboard can be waked up from suspend mode through the internal modem ring-in.

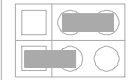
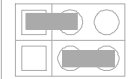

Fig 8: Internal Modem Ring-In Connector

2.12 RESERVED JUMPERS

JP6 is reserved for manual setting of Cyrix CPU linear burst. Default setting is OFF.

2.13 MEMORY CONFIGURATION

The mainboard lets user upgrade system memory via SIMM or DIMM sockets on the mainboard. On board memory is located in three banks: Bank 0, Bank 1 and Bank 2. Four SIMM sockets (SIMM1, SIMM2, SIMM3, SIMM4) are provided for SPM, FPM and EDO RAM SIMM and two DIMM sockets (DIMM1, DIMM2) are available for the SDRAM DIMM.

Note: *The type of SIMM1/SIMM2 must be same.
The type of SIMM3/SIMM4 must be same.
SIMM1/SIMM2 and DIMM1 can not co-exist.*

Table 5 provide the typical memory configurations supported by the mainboard.

Bank 0			Bank 1	Bank 2
(SIMM1)	(SIMM2)	(DIMM1)	(DIMM2)	(SIMM3/4)
Installed	None	None	None	None
Installed	Installed	None	None	None
None	None	Installed	None	None
Installed	Installed	None	Installed	None
None	None	Installed	Installed	None
Installed	Installed	None	None	Installed
None	None	Installed	None	Installed
Installed	Installed	None	Installed	Installed
None	None	Installed	Installed	Installed

Table 6

The memory size of SIMM can be 8MB, 16MB, 32MB or 64MB. The memory of DIMM can be 8MB, 16MB, 32MB, 64MB or 128MB.

CHAPTER 3

CONNECTOR CONFIGURATION

Once the mainboard has been fastened into system case, the next step is to connect the internal cables and external cables. The mainboard connectors have varying numbers of pins and are the points of contact between the mainboard and other parts of the computer.

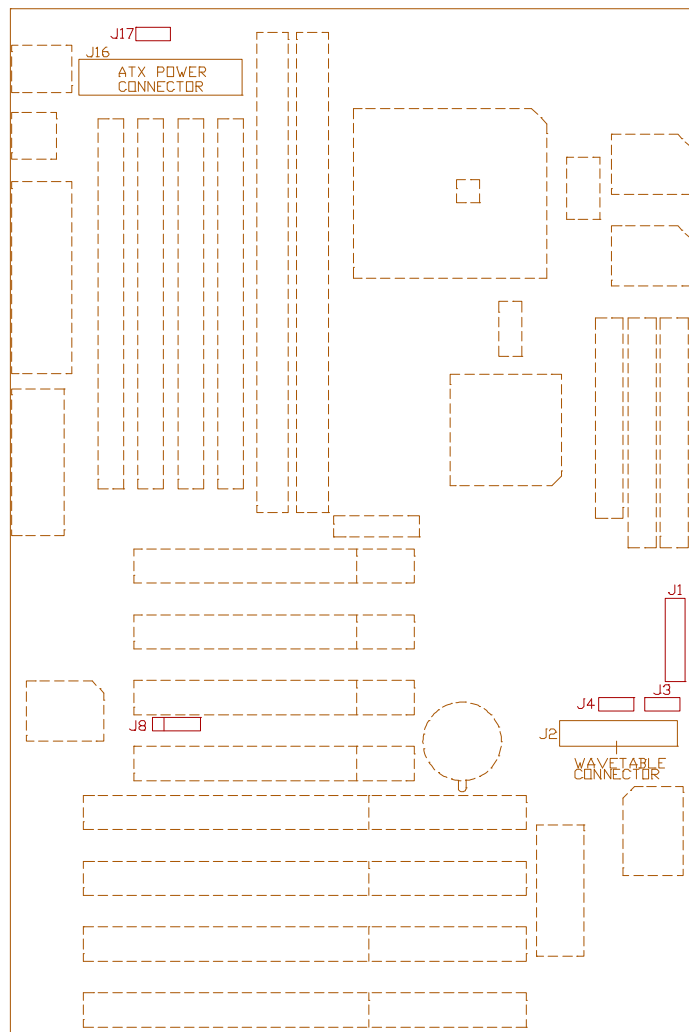

Fig 9 Connector Location

3.1 J1 - MULTIPLE FUNCTION JUMPER

J1 is a front panel multi-function jumper include speaker, reset, keylock, Harddisk LED, ATX power switch, ACPI (suspend) LED and power button (suspend switch). The pin definition is as following figure.

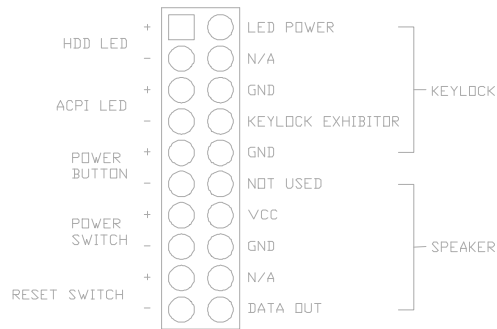

Fig. 10 Multiple Function Jumper

Power Switch: It is used to switch on or off the power supply.
 Power Button: If BIOS Setup item Suspend Option is “Static Suspend”, its function is forcing the system enter suspend mode. If BIOS Setup item Suspend Option is “0V Suspend”, its function is power off the system.

3.2 J2 - WAVETABLE EXPANSION CONNECTOR

J2 is a 2x13 pin male connector, which is used to connect the hardware wavetable expansion card.

3.3 J3 - CD-ROM AUDIO CONNECTOR (MISUMI/PANASONIC)

J3 is four pin connector, which is used to connect with the Panasonic or Misumi CD-ROM audio output. The pin definition is as following:

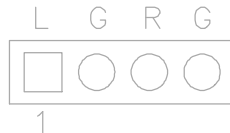

Fig. 11 CD-ROM Audio Connector

3.4 J4 - CD-ROM AUDIO CONNECTOR (SONY)

J4 is a four pin connector, which is used to connect with the Sony CD-ROM audio output. This pin definition is as following:

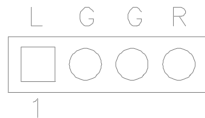

Fig. 12 CD-ROM Audio Connector

3.5 J8 - IrDA/FAST IR CONNECTOR

J8 is a five pin connector, which use the UART2 as interface for IrDA. You must also configure the setting through “UART2 Mode” is Integrated Peripheral Setup to select whether UART2 is used for COM2 or HPSIR/SKSIR. The pin definition is as following:



Fig. 13 IrDA/Fast IR Connector

3.6 J17 - CPU FAN CONNECTOR

J9 is a three pin connector, which is used to connect with the CPU Fan power cable.

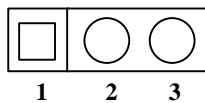

Fig. 14 CPU Fan Connector

3.7 J16 - ATX POWER CONNECTOR

J16 is a 2x10 pin male header connector. Plug the power connector of the ATX power supply onto the connector.

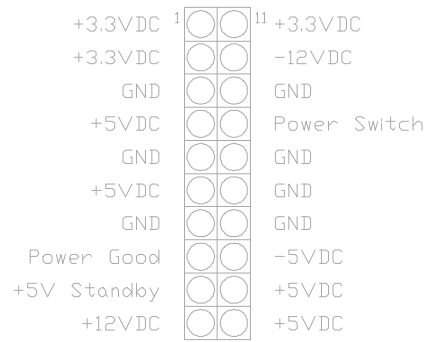

Fig. 15 ATX Power Connector

Connector Configuration

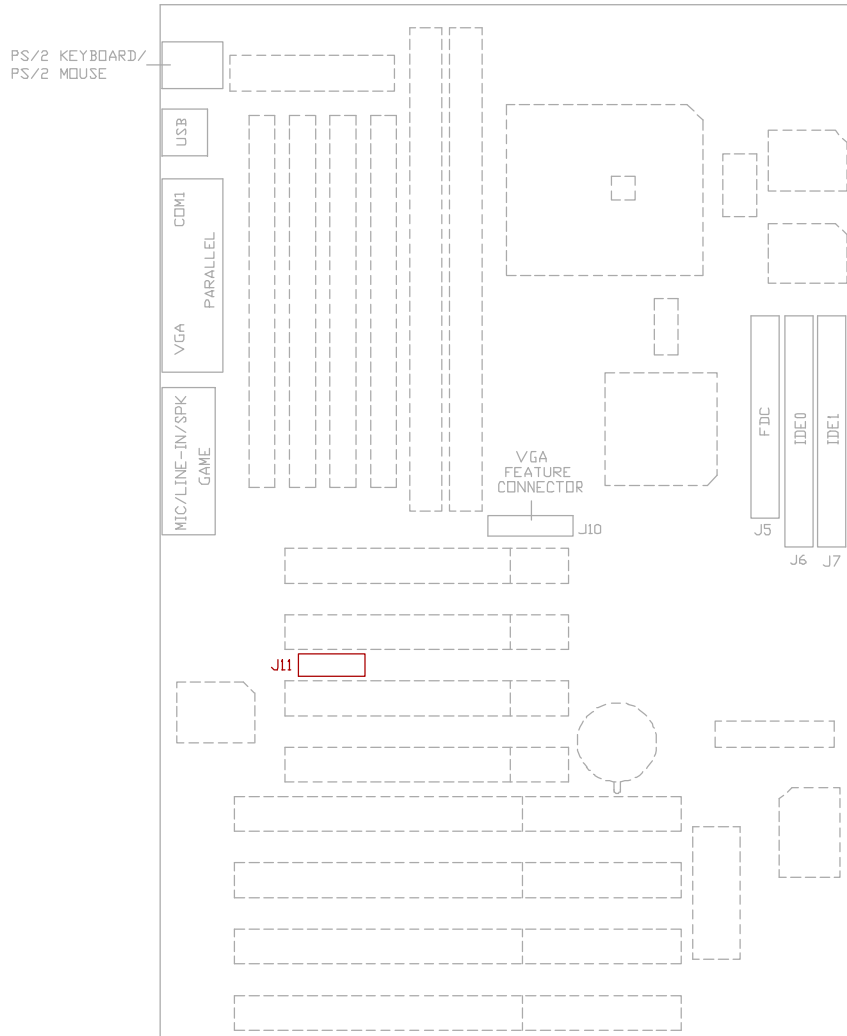

Fig. 16 Connector Location

3.8 J5 - FLOPPY DRIVE CONNECTOR

This connector supports the floppy drive ribbon cable. After connecting the single end to the board, connect the two plugs on the other end to the floppy drive.

3.9 J6, J7 - PRIMARY/SECONDARY IDE CONNECTORS

These connectors support the provided IDE hard disk ribbon cable. After connecting the single end to the board, connect the two plugs on the other end to your hard disk.

3.10 J11 - SERIAL PORT COM2 CONNECTOR

This connector support the provided serial port ribbon cable without mounting bracket.

3.11 J10 - FEATURE CONNECTOR

This connector is the feature connector for VGA controller.

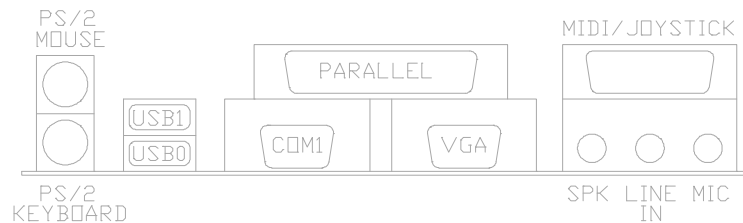

Fig. 17 Feature Connector

3.12 PS/2 KEYBOARD CONNECTOR

This connector is a six-pin female mini DIN connector using a PS/2 plug. If a standard AT size keyboard plugs, you may use the DIN to mini DIN adaptor.

3.13 PS/2 MOUSE CONNECTOR

This connector is a six-pin female mini DIN connector using a PS/2 plug. Plug the jack on the PS/2 mouse cable into this connector.

3.14 UNIVERSAL SERIAL BUS PORTS 0 & 1

These connectors are two four pin female sockets which are available for connecting USB device.

3.15 PARALLEL PORT CONNECTOR

This is a D-Type 25 pin female connector.

3.16 SERIAL PORT COM1

This is a D-Type 9 pin male connector for pointing devices or other serial devices.

3.17 AUDIO PORT CONNECTOR

Three 1/8" female connectors used as speaker, line in and microphones. **SPK** can be connected to headphones or preferably powered speakers. **Line In** allows tape players or other audio sources to be recorded by your computer or played through the SPK. **MIC** allows microphones to be connected for inputting voice.

CHAPTER 4

AWARD BIOS SETUP GUIDE

This following manual is specially provided for the BIOS supported system. After the configuration of the mainboard, and have assembled the components, user can turn on the completed system. At this point, run the software setup to ensure that the system information is correct.

The software setup of the system board is achieved through Basic Input-Output System (BIOS) programming. Use the BIOS setup program to tell the operating system what type of devices (such as disk drives) are connected to the system board.

The system setup is also called CMOS setup. Normally, users need to run system setup if either the hardware configuration is not identical with information contained in the CMOS RAM, or the CMOS RAM has lost power.

4.1 AWARD BIOS SETUP

The setup program provided with the mainboard is the Award BIOS from Award Software, Inc. Enter the AWARD Setup program's Main Menu as follows:

1. Turn on or reboot the system. After a series of diagnostic check, the following message appear:

"Press DEL to enter SETUP"

Chapter 4

2. Press the key to enter the AWARD BIOS setup program and the following screen appears:

ROM PCI/ISA BIOS (2A5IIG39)
CMOS SETUP UTILITY
AWARD SOFTWARE, INC.

STANDARD CMOS SETUP	INTEGRATED PERIPHERALS
BIOS FEATURES SETUP	SUPERVISOR PASSWORD
CHIPSET FEATURES SETUP	USER PASSWORD
POWER MANAGEMENT SETUP	IDE HDD AUTO DETECTION
PNP/PCI CONFIGURATION	SAVE & EXIT SETUP
LOAD SETUP DEFAULTS	EXIT WITHOUT SAVING
Esc : Quit F10 : Save & Exit Setup	↑ ↓ → ← : Select Item (Shift)F2 : Change Color
Time, Data, Hard Disk Type...	

Fig. 18

3. Choose an option and press <Enter>. Modify the system parameters to reflect the options installed in the system. (see the following sections for more information).
4. Press <ESC> at anytime to return to the Main Menu.
5. In the Main Menu, choose "SAVE AND EXIT SETUP" to save change and reboot the system. Choosing "EXIT WITHOUT SAVING" to ignore all changes and exists the program.

4.2 STANDARD CMOS SETUP

ROM PCI/ISA BIOS (2A5IIG39)
STANDARD CMOS SETUP
AWARD SOFTWARE, INC.

Date (mm:dd:yy) : Wed, May 21 1997							
Time (hh:mm:ss) : 20 : 27 : 55							
HARD DISKS	TYPE	SIZE	CYLS	HEAD	PRECOMP	LANDZ	SECTOR MODE
Primary Master :	Auto	0 0	0	0	0	0	AUTO
Primary Slave :	None	0 0	0	0	0	0	-----
Secondary Master :	None	0 0	0	0	0	0	-----
Secondary Slave :	None	0 0	0	0	0	0	-----
Drive A : 1.44M , 3.5in.				Base Memory: 0K			
Drive B : None				Extended Memory: 0K			
Floppy 3 Mode Support : Disabled				Other Memory: 512K			
Video : EGA/VGA				Total Memory: 512K			
Halt On : All Errors							
Esc : Quit		↑ ↓ → ← : Select Item			PU/PD/+/- : Modify		
F1 : Help		(Shift)F2 : Change Color					

Fig. 19

Date(mm/dd/yy)	Type the current date.
Time(hh:mm:ss)	Type the current time.
Hard Disks	Choose from the standard hard disk types 1 to 45. Type 47 is user definable. Type Auto is for auto detect the hard disk type.
Drive A & B	Choose 360K, 5.25in.; 1.2M, 5.25in.; 720K, 3.5in.; 1.44M, 3.5in.; 2.88MB 3.5in. or None
Video	Choose EGA/VGA, CGA 40, CGA 80, or MONO,
Halt On	Choose All Errors; No Errors; All, But Keyboard; All, But Diskette or All, But Disk/Key
Floppy 3 Mode Support	Choose Enable to allow floppy drive support 3 mode

4.3 BIOS FEATURES SETUP

ROM PCI/ISA BIOS (2A5IIG39)
 BIOS FEATURES SETUP
 AWARD SOFTWARE, INC.

Virus Warning	: Disabled	Video BIOS Shadow	: Enabled
CPU Internal Cache	: Enabled	C8000-CBFFF Shadow	: Disabled
External Cache	: Enabled	CC000-CFFFF Shadow	: Disabled
Quick Power On Self Test	: Disabled	D0000-D3FFF Shadow	: Disabled
Boot Sequence	: A,C, SCSI	D4000-D7FFF Shadow	: Disabled
Swap Floppy Drive	: Disabled	D8000-DBFFF Shadow	: Disabled
Boot Up Floppy Seek	: Enabled	DC000-DFFFF Shadow	: Disabled
Boot Up Numlock Status	: On		
Boot Up System Speed	: High		
Typematic Rate Setting	: Disabled		
Typematic Rate (Chars/Sec)	: 6		
Typematic Delay (Msec)	: 250		
Security Option	: Setup		
PCI/VGA Palette Snoop	: Disabled		
OS Select For DRAM > 64MB	: Non-OS2		
		ESC: Quit	↑ ↓ → ←: Select Item
		F1: Help	PU/PD/+/-: Modify
		F5: Old Values	(Shift)F2: Color
		F7: Load Setup Defaults	

Fig. 20 BIOS Setup Defaults

A short description of the screen items follows:

Virus Warning: When enabled, you receive a warning message if a program (specifically, a virus) attempts to write to the boot sector or the partition table of the hard disk drive. You should then run an anti-virus program.

CPU Internal Cache: Choose Enabled or Disabled. This option lets user choose whether to use CPU internal cache memory. The default is Enabled.

External Cache: Choose Enabled or Disabled. This option lets user choose whether to use secondary cache memory. The default is Enabled.

Quick Power On Self Test: Choose Enabled or Disabled. This option let the POST sequence runs longer for through tests.

Boot Sequence: With the default setting the BIOS first attempts to boot from drive A: and then, if unsuccessful, from hard disk C: and SCSI. User can select other boot up sequence. Available sequences are "C,A,SCSI", "C,CDROM,A", "CDROM,C,A", "D,A,SCSI", "E,A,SCSI", "F,A,SCSI", "SCSI,A,C", "SCSI,C,A", "C only", "LS120,C".

Swap Floppy Drive: Choose Enabled or Disabled. This option lets end users to change the Drive A: or B: to others.

Boot Up Floppy Seek: Choose Enabled or Disabled. "Disabled" provides a fast boot and reduces the possibility of damage to the heads.

Boot Up NumLock Status: Choose On or Off. On puts numeric keypad in Num Lock mode at boot-up. Off puts numeric keypad in arrow key mode at boot-up.

Boot Up System Speed: Choose High or Low. Set the CPU timing at Boot Up, the default is high.

Typematic Rate Setting: Choose Enabled or Disabled. Enabled will determines the typematic rate defined by following two options.

Typematic Rate: The number selected 6,8,10... indicates how fast the number of characters can response in one second.

Typematic Delay (Msec): The number selected indicates the time period between two identical keys appear.

Security Option: Choose Setup or System. If system is selected, the password should be set.

PCI/VGA Palette Snoop: Select Disabled or Enabled. If Enabled the MPEG Card can synchronised with PCI/VGA.

OS Select For DRAM > 64MB: Select Disabled or Enabled. If the system memory is larger than 64MB and running OS/2, please enable this item. However, if it use other operating system, please disable this feature. Furthermore, if the system memory is less than 64MB, the BIOS will ignore this function.

Video BIOS Shadow: ROM Shadow copies Video BIOS code from slower ROM to faster RAM. Video BIOS can then execute from RAM.

C8000-CFFFF Shadow: If enabled and BIOS is present in this segment, then the BIOS is shadowed.

D0000-DFFFF Shadow: If enabled and BIOS is present in this segment, then the BIOS is shadowed.

4.4 CHIPSET FEATURES SETUP

The Advanced Chipset Setup option is used to change the values of the chipset registers. These registers control most of the system options in the computer.

Note: Change these Settings only if user is familiar with the Chipset.

ROM PCI/ISA BIOS (2A5IIG39)
CHIPSET FEATURES SETUP
AWARD SOFTWARE, INC.

Auto Configuration	: Enabled	ISA Bus Clock Frequency	: PCICLK/4
Refresh Cycle Time (us)	: 187.2	VGA Shared Memory Size	: 1 MB
SDRAM WR Retire Rate	: X-2-2-2	VGA Memory Clock (MHz)	: 55
SDRAM Wait State Control	: 1WS	Linear Mode SDRAM Support	: Disabled
Enhanced Memory Write	: Disabled	CPU Core Voltage	: Auto
Read Prefetch Memory RD	: Enabled		
CPU to PCI Post Write	: 3T		
CPU to PCI Burst Mem. WR	: Disabled		
		ESC: Quit ↑ ↓ → ←: Select Item	
		F1: Help PU/PD/+/-: Modify	
		F5: Old Values (Shift)F2: Color	
		F7: Load Setup Defaults	

Fig. 21

A short description of the screen items follows:

Auto Configuration: Auto Configuration selects predetermined optional values of chipset parameters. When disabled, chipset parameters revert to setup information stored in CMOS.

Refresh Cycle Time (us): This option specify the Refresh Cycle Time. The options are “15.6”, “62.4”, “124.8” and “187.2”.

CPU to PCI Post Write: This option is used to control the timing of the CPU to PCI Post Write buffer. The available option is “3T”, “4T” and Disabled. The default value is “4T”.

CPU to PCI Burst Mem. WR: It is used to enable or disable the CPU to PCI Burst Memory Write.

ISA Bus Clock Frequency: It is used to select the bus clock for the ISA bus. The available options are “7.159MHz”, “CPUCLK/4” and “CPUCLK/3”.

CPU Speed	ISA Bus Clock Frequency
75MHz	CPUCLK/3
Other than 75MHz	CPUCLK/4

VGA Shared Memory Size: If external VGA card is installed, this option will not be shown. It is used to select the video ram size shared with the system memory, the available options are “0.5MB”, “1MB”, “1.5MB”, “2MB”, “2.5MB”, “3MB”, “3.5MB” and “4MB”.

VGA Memory Clock (MHz): If external VGA card is installed, this option will not be shown. It is used to select the VGA memory clock frequency of the on-board graphics controller used. The available frequency ranges from 40MHz to 70MHz. The default value is 55MHz.

Linear Mode SDRAM Support: Select enabled to support the Linear Mode SDRAM.

CPU Core Voltage: This feature is implemented to simplify the jumper setting for end user. Set it at Auto, the motherboard can auto detect the core voltage of any CPU and switching power will generate the correct voltage to support the CPU. Use also can select the CPU core voltage through the BIOS. The option is 2.8, 2.9, 3.2, 3.3, 3.52. If this option is set at “Disabled”, user should select the CPU core voltage by switch 1 and 2 (Refer to Section 2.4.1).

4.5 POWER MANAGEMENT SETUP MENU

The Power Management Setup option is used to change the values of the chipset registers for system power management functions.

ROM PCI/ISA BIOS (2A5IIG39)
POWER MANAGEMENT SETUP
AWARD SOFTWARE, INC.

Power Management	: User Define	HDD Ports Activity	: Enabled
PM Control by APM	: Yes	VGA Activity	: Enabled
Video Off Option	: Susp, Sby → Off	IRQ3 (COM 2)	: Enabled
Video off Method	: V/H SYNC+Blank	IRQ4 (COM 1)	: Enabled
Switch Function	: Break/Wake	IRQ5 (LPT 2)	: Enabled
Suspend Option	: Static Suspend	IRQ6 (Floppy Disk)	: Enabled
MODEM Use IRQ	: 3	IRQ7 (LPT 1)	: Enabled
Hot Key Power Off	: Enabled	IRQ8 (RTC Alarm)	: Disabled
	PM Timers	IRQ9 (IRQ2 Redir)	: Enabled
HDD Off After	: Disabled	IRQ10 (Reserved)	: Enabled
Suspend Mode	: Disabled	IRQ11 (Reserved)	: Enabled
	PM Events	IRQ12 (PS/2 Mouse)	: Enabled
COM Ports Activity	: Enabled	IRQ13 (Coprocessor)	: Enabled
LPT Ports Activity	: Enabled	IRQ14 (Hard Disk)	: Enabled
		IRQ15 (Reserved)	: Enabled
		ESC: Quit	↑ ↓ → ←: Select Item
		F1: Help	PU/PD/+/-: Modify
		F5: Old Values	(Shift)F2: Color
		F7: Load Setup Defaults	

Fig. 22

A short description of the screen items follows:

Power Management: Available selection are “Disabled”, “User Define”, “Max Saving” and “Min Saving”:

“Disabled” will disable all the power saving functions.

“User Define” makes the time period waiting for Suspend Mode to be programmed.

“Max Saving” will set the time period waiting for Suspend Mode to be 20 seconds.

“Min Saving” will set the time period waiting for Suspend Mode to be 40 minutes.

PM Control by APM: Available options are “Yes” and “No”. To choose “Yes” to let the Power Management Function to be control by the MS APM software.

Video Off Option: Select the mode in which you want the monitor to blank. The options are “Always On”, “Susp. Stby → Off”, “Susp, Stby → Off” and “All mode → Off”.

Video Off Method: Choose V/H SYNC+Blank, DPMS or Blank Screen. This is monitor Power Saving Method. V/H SYNC+Blank means turn off Vertical, Horizontal scanning and blank the screen. Blank Screen will blank the display screen. DPMS (Display Power Management System) can allow the System BIOS control the Display Card to turn off the Display.

Suspend Option: Available options are “Static Suspend” and “0V Suspend”. For “Static Suspend” option, the system will enter the suspend mode with the power supply still switching on by switching the power button. For “0V Suspend” option, the system will fully power off the system when it entering the suspend mode by switching the power button. With installing the Award Zero-Volt Data-Suspend Utility (ZVHDD), the system will resume back when the system power on again by switching the power switch.

MODEM Use IRQ: Available options are 3, 4, 5, 7, 9, 10, 11 and NA. It is used to choose the interrupt line that the Modem is used. “NA” means not available.

Suspend Mode: To set the time period waiting for Suspend Mode when the Power Management function is set to “User Define”.

HDD Off After: To select the time period will turn the HDD off. Accessing the HDD again will take a few seconds for HDD to spin up for operation.

IRQ 3 - IRQ15: When it is enabled, the system will monitor the activity of the corresponded system IRQ to turn on or off the power management functions.

4.6 PCI CONFIGURATION

The PCI Configuration Setup option is used to configure the PCI add-on Cards on PCI Slots. Without proper setup the PCI Add-on Cards might not function properly.

ROM PCI/ISA BIOS (2A5IIG39)
 PCI CONFIGURATION
 AWARD SOFTWARE, INC.

Resources Controlled By	: Manual	PCI IRQ Activated By	: Level
Reset Configuration Data	: Disabled	PCI IDE 2nd Channel	: Enabled
IRQ-3 assigned to	: Legacy ISA	PCI IDE IRQ Map To	: PCI-AUTO
IRQ-4 assigned to	: Legacy ISA	Primary IDE INT#	: A
IRQ-5 assigned to	: PCI/ISA PnP	Secondary IDE INT#	: B
IRQ-7 assigned to	: Legacy ISA		
IRQ-9 assigned to	: PCI/ISA PnP		
IRQ-10 assigned to	: PCI/ISA PnP		
IRQ-11 assigned to	: PCI/ISA PnP		
IRQ-12 assigned to	: PCI/ISA PnP		
IRQ-14 assigned to	: Legacy ISA		
IRQ-15 assigned to	: Legacy ISA		
DMA-0 assigned to	: PCI/ISA PnP	ESC: Quit	↑ ↓ → ←: Select Item
DMA-1 assigned to	: PCI/ISA PnP	F1: Help	PU/PD/+/-: Modify
DMA-3 assigned to	: PCI/ISA PnP	F5: Old Values	(Shift)F2: Color
DMA-5 assigned to	: PCI/ISA PnP	F6: Load BIOS Defaults	
DMA-6 assigned to	: PCI/ISA PnP	F7: Load Setup Defaults	
DMA-7 assigned to	: PCI/ISA PnP		

Fig. 23

Note: Change these Settings only if user is familiar with the Chipset and all the PCI Add-on Cards functions.

A short description of the screen items follows:

Resources Controlled By: The Award Plug and Play BIOS can automatically configure all the boot and Plug and Play compatible device. If you select Auto, all the interrupt (IRQ) and DMA assignment fields disappear, as the BIOS automatically assigns them.

Reset Configuration Data: If enable this option, the BIOS will clear and reset the ESCD after hardware reset.

IRQ#/DMA# assigned to: These items will be shown only when “Resources Controlled By” option is set the “Manual”. The available options are “Legacy ISA” and “PCI/ISA PnP”. If the option is set to “Legacy ISA”, the BIOS will never assign the specified IRQ/DMA resource to PCI or ISA PnP Devices. If “PCI/ISA PnP” is chosen, the BIOS will make the specified IRQ/DMA have a chance to be assigned to the PCI or ISA PnP devices.

PCI IRQ Active By: Choose Level or Edge. The default settings is Level.

PCI IDE IRQ Map To: Choose PCI-AUTO, PCI-SLOT1, PCI-SLOT2, PCI-SLOT3, ISA. The default setting is PCI-AUTO.

4.7 INTEGRATED PERIPHERALS SETUP MENU

The Integrated Peripherals setup option is need to change the values of the I/O chipset registers for I/O functions.

ROM PCI/ISA BIOS (2A5IIG39)
INTEGRATED PERIPHERALS
AWARD SOFTWARE, INC.

Internal PCI/IDE : Both IDE Primary Master PIO : Auto IDE Primary Slave PIO : Auto IDE Secondary Master PIO : Auto IDE Secondary Slave PIO : Auto Primary Master Ultra DMA : Auto/Disabled Primary Slave Ultra DMA : Auto/Disabled Secondary Master Ultra DMA : Auto/Disabled Secondary Slave Ultra DMA : Auto/Disabled IDE Burst Mode : Disabled IDE Data Port Post Write : Disabled IDE HDD Block Mode : Disabled Onboard FDD Controller : Enabled Onboard Serial Port 1 : 3F8/IRQ4 Onboard Serial Port 2 : 2F8/IRQ3 UART 2 Mode : HPSIR IR Function Duplex : Full Rx/D, Tx/D Active : Hi, Hi Onboard Parallel Port : 378/IRQ7	Onboard Parallel Mode : ECP/EPP ECP Mode Use DMA : 1 Parallel Port EPP Type : EPP1.9 USB Controller : Disabled USB Keyboard Support : Disabled Power Button Over Ride : Enabled Ring Power Up Control : Enabled Power Up by Alarm : Disabled ESC: Quit ↑ ↓ → ←: Select Item F1: Help PU/PD/+/-: Modify F5: Old Values (Shift)F2: Color F7: Load Setup Defaults
--	---

Fig. 24

Chapter 4

A short description of the screen items follows:

Internal PCI/IDE: This item is used to set the onboard IDE controller. The settings are Primary, Secondary, Both or Disabled. The default setting is Both.

IDE HDD Block Mode: This allows your hard disk controller to use the fast block mode to transfer data to your hard disk drive.

IDE Primary Master PIO/IDE Primary Slave PIO/IDE Secondary Master PIO/IDE Secondary Slave PIO: Available selection are “Auto”, “Mode 0”, “Mode 1”, “Mode 2”, “Mode 3” and “Mode 4”. To choose “Auto”, the system BIOS will scan the IDE device and decide which mode of the device is . Otherwise the user should key in the mode of the device to the corresponding field.

Some harddisks cannot work properly with its corresponding timing, please set a slower timing.

Primary Master Ultra DMA/Primary Slave Ultra DMA/Secondary Master Ultra DMA/Secondary Slave Ultra DMA: Available selection are “Auto” or “Disabled”. To choose “Auto”, the system BIOS will scan the IDE device and decide Ultra DMA supported or not.

Onboard FDD Controller: Choose Enabled or Disabled. “Enabled” allows onboard Floppy Drive Controller to be functioned, otherwise the users should use other sources..

Onboard Serial Port 1: Choose None, Auto or from COM1, COM3, COM4 with different I/O Address. While choosing proper I/O Address, be sure not to cause Address conflict with other I/O devices.

Onboard Serial Port 2: Choose None, Auto or from COM1, COM2, COM3, COM4 with different I/O Address. While choosing proper I/O Address, be sure not to cause Address conflict with other I/O device.

UART 2 Mode: Choose Standard, ASKIR and HPSIR for IrDA serial Interface.

IR Function Duplex: This item will be shown only when **UART 2 Mode** is selected to ASKIR or HPSIR. The available options are “Full” and “Half”. It is used to choose the IR function working in full duplex mode or half duplex mode correspondingly.

RxD, TxD Active: This item will be shown only when **UART 2 Mode** is selected to ASKIR or HPSIR. The available options are “Hi, Hi”, “Hi, Lo”, “Lo, Hi” and “Lo, Lo”. It is used to configure the logic level of Receive and Transmit signal in IrDA interface.

Onboard Parallel Port: Choose None or with four different I/O Address and corresponding IRQx. While choosing proper I/O Address, be sure not to cause Address conflict with other I/O devices.

Onboard Parallel Mode: Choose SPP, EPP/SPP, ECP, ECP/EPP Mode. Make proper selection with the attached printer port device.

ECP Mode Use DMA: Choose “1” or “3” to select the DMA channel used for the ECP device. This item is shown if the **Onboard Parallel Mode** is chosen as “ECP” or “ECP/EPP” option.

Parallel Port EPP Type: Choose “EPP1.7” or “EPP1.9”, which is used to configure the EPP using either EPP1.7 or 1.9 timing specification. This item is shown if the **Parallel Mode** is chosen as “EPP” or “ECP/EPP” option.

USB Controller: Choose Enabled or Disabled. “Enabled” allows the on board Universal Serial Bus (USB) Controller to be functioned.

USB Keyboard Support: This option only shown when USB controller is enabled. Choose Enabled or Disabled to support the USB K/B or not.

Ring Power Up Control: Choose Enabled or Disabled. “Enabled” allows the ring in signal (Modem) waking up the system.

4.8 LOAD SETUP DEFAULTS MENU

This Main Menu item uses the default setup values. Use this option as a diagnostic aid if the system behaves erratically. Choose this item and the following message appears:

‘Load SETUP Defaults (Y/N)? N’

To use the Power-On defaults, change the prompt to “Y” and press <Enter>.

4.9 SUPERVISOR PASSWORD

Two level of password is supported. Depending on the setting of the “Security Option” in the “BIOS FEATURES SETUP”, the system BIOS will ask for password every time booting up the System or entering BIOS Setup. With the supervisor password, both the system booting and BIOS setup changing is allowed.

This main menu item lets the user to set up the Supervisor Password.

Change the password as follows:

1. Choose "PASSWORD SETTING" in the Main Menu and press <Enter>. The following message appears:

'ENTER PASSWORD:'

2. Enter the Password and press <Enter>. The following message appears:

"CONFIRM PASSWORD:"

Important: Keep a safe record of the new password. If forget or lose the password, the only way to access the system is to disconnect the CMOS batteries and then re-enter the password.

4.10 USER PASSWORD

With the user password, only booting up the system is accepted, but changing the BIOS setup is not allowed.

4.11 IDE HDD AUTO DETECTION

When users can not find the Hard Disk information, it is very helpful to use this option.

1. Choose this item and press <Enter>.
2. After couple seconds, the screen will appear the Hard Disk information and following message:

"SELECT PRIMARY MASTER OPTION(N=SKIP): N"

3. Enter Y or N to confirm the acceptance then enter.
4. The process will repeat for Primary Slave, Secondary Master and Secondary Slave Hard Disks.

4.12 SCSI HARD DISK INSTALLATION

In Standard CMOS Setup Utility, select hard disk type to be "Not Installed". In Advanced CMOS Setup Utility, Disable "Adapter ROM Shadow DC00". On the SCSI Controller card, set the jumpers which configure the SCSI card BIOS segment address located at DC00 or DE00. Format the SCSI disk by the Formatter provided in the SCSI BIOS.

4.13 SAVE & EXIT SETUP MENU

When you select this function, the following message will appear at the centre of the screen to assist you to Save data to CMOS and Exit the Setup.

Save to CMOS and Exit (Y/N)?

4.14 EXIT WITHOUT SAVING MENU

When you select this function, the following message will appear at the centre of the screen to assist you to Abandon all Data and Exit Setup.

Quit Without Saving (Y/N)?

CHAPTER 5

SOFTWARE INSTALLATION

In order to let the system board to work efficiently, a series of drivers have to installed according to the operating system used. The drivers are distributed by CD-ROM Title. Please refer to the following section:

5.1 PCI IDE DRIVER INSTALLATION

Please refer to the **README.TXT** file in \DRIVERS\IDE directory for detail installation procedures to be used in various kind of operation system (DOS, Netware, Windows NT, OS/2, Windows 95, Windows 3.1).

5.2 PCI VGA DRIVER INSTALLATION

- (1) Set VGA Share Memory Size to “0.5MB”, “1MB”, “1.5MB”, “2MB”, “2.5MB”, “3MB”, “3.5MB” or “4MB” in BIOS Setup to configure the video memory size shared by the VGA controller.
- (2) Please refer to README.TXT file in each directory under \DRIVERS\VGA for detail installation procedures to be used in various kind of operation system.

5.3 SOUND DRIVER INSTALLATION

- (I) **Windows 3.1**
Run SETUP.EXE under \DRIVERS\SOUND\WIN31 for installation of sound driver for Windows 3.1 system.
- (II) **Windows 95**

When Win95 system ask you “Please insert the disk labeled ‘Driver Disk’ and then click OK”. Click OK. In the “Copy files from” window, type “D:\drivers\sound\win95”. The system will install the driver from CD-Title.

5.4 THE AUDIORACK32 FOR WIN95

5.4.1 INTRODUCTION

The *AudioRack32* enables you to take advantage of your computer's audio capabilities with all of the controls conveniently in one compact space. You can play audio CDs, wave files (in .WAV and .AUD formats), and MIDI files (in .MID and .RMI formats). With the multi-source Audio Mixer, you can blend these sources with line-in and microphone sources any way you choose. Add tone control and spatialization to your computer with the 3-D/Tone Controller. You can then record your creations as wave files and edit them with the Audio Recorder.

The *AudioRack32* has six main parts:

- Command Center—customizes the appearance of the *AudioRack32*.
- 3-D/Tone Controller—adds 3-D stereo and tone controls to the *AudioRack32*.
- Audio Mixer—controls the volume and balance of the *AudioRack32* devices.
- Digital Audio Player—plays and records files in the .WAV format.
- MIDI Player—enables you to play MIDI files.
- Compact Disk Player—enables you to play audio CDs on a CD-ROM drive.

In addition, the *AudioRack32* has a miniature mode enabling you to control the *AudioRack32* while using minimal screen space.

The Audio Recorder is a separate application from the *AudioRack32*. It can be used to add effects and edit files recorded with the Digital Audio Player or by the Audio Recorder itself. The Audio Recorder can be launched from the *AudioRack32* Digital Audio Player or on its own.

5.4.2 INSTALLING THE *AudioRack32*



Placing the multimedia CD-ROM Driver in the CD-ROM Drive or *AudioRack32* disk in a floppy drive, click **Start** on the taskbar and choose **Run** from the popup menu.

In the Run dialog box, type the letter of the drive and setup (for example, D:\APPS\AUDIO\ARCK32\SETUP), then click **OK**. The first Audio**Rack**32 Setup dialog box appears.

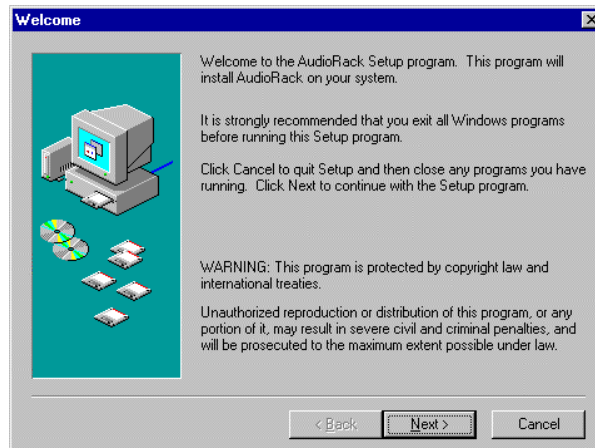

Note the instructions, then click **Next** to proceed or **Cancel** to leave Setup.

Next the Choose Destination Location dialog box appears.

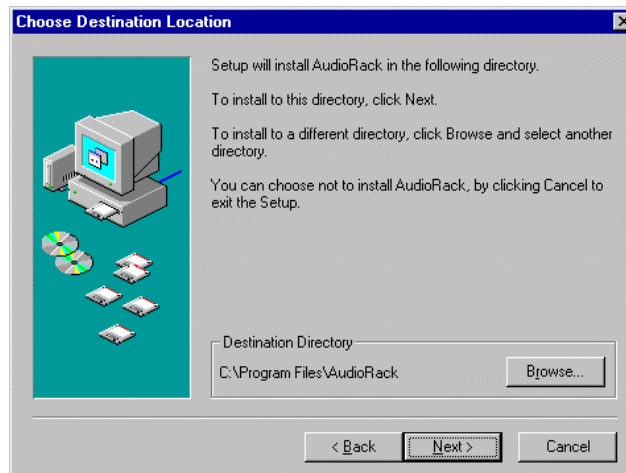

Click **Next** to install the *AudioRack32* in the default directory or **Browse** to choose a different directory. Click on **Cancel** to leave the Setup program or **Back** to return to the Welcome dialog box.

Chapter 5

If you wish to install the *AudioRack32* in a directory other than the default directory, enter the directory path in the Browse dialog box.

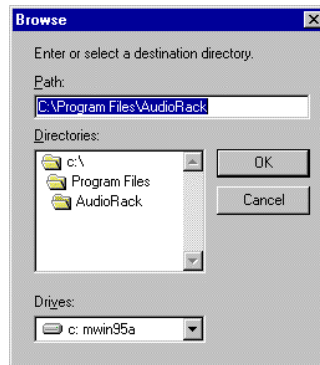

When you are done click **OK** or **Cancel** to return to the Choose Destination Location dialog box.

If the directory you designate doesn't exist, you will be asked to confirm your selection. Click **Yes** to proceed or **No** to go back and enter a new destination directory.

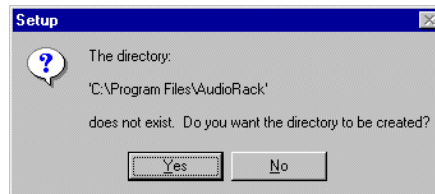

Once you have chosen the default directory or entered a directory of your own choosing, the Setup program will install *AudioRack32*.

Before completing installation of the *AudioRack32*, you will be given the option to view the README file before exiting the setup program

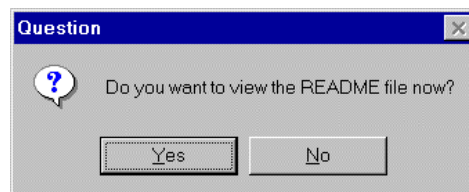

Click **Yes** to view the README file now or **No** to skip the README file and finish the installation.

Upon successful completion of the *AudioRack32* installation, the following message will be displayed.

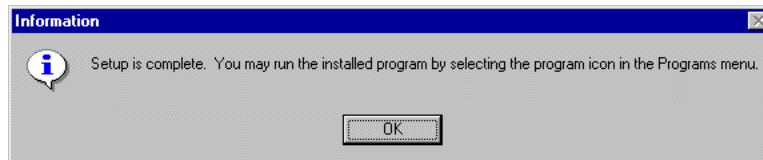

5.4.3 UNINSTALLING THE *AudioRack32*

To remove the *AudioRack32* from your system, start by clicking on (but not releasing) **Start** on the taskbar. Move the cursor to **Settings** and select **Control Panel**. From the Control Panel choose **Add/Remove Programs**. Select *AudioRack 2.0* from the list and click **Add/Remove**. After you confirm your decision, the *AudioRack32* will be uninstalled.

5.5 XING MPEG PLAYER (OPTIONAL)

Xing is a software MPEG player for the Video CD and MPEG format data. Please refer to the README.TXT file in the diskette for details about the installation.

CHAPTER 6

AWARD ZERO-VOLT DATA-SUSPEND UTILITY

6.1 INTRODUCTION

The zero-volt data-suspend utility, **ZVHDD.EXE**, stores all the information about your current operating session on your hard drive when you turn off your system, using just one Windows function to replace the sometimes tedious process of closing data files, applications, and the Windows environment. Next time you turn your system on, the complete session resumes, just as it was.

The saves session data includes all the programs and data files loaded into system memory during the session. For example, you may be running multiple applications, such as Microsoft Excel, WordPerfect, and CorelDraw, under Windows 95. Normally, to turn off your computer, you must close all open data files and applications and then exit Windows. When you want to resume work where you left off, you must boot the computer, wait for Windows to open, open your application(s), and load the data file(s) you were editing.

Think how quick and convenient it would be if you could issue just one command to end your current session. And how quick and convenient it would also be if your session resumed exactly where you left off next time you turned on the computer! The Award Zero-Volt Data-Suspend utility offers this convenience.

6.2 PREPARATION

1. In the **BIOS Power Management Setup Menu** set the **Suspend Mode** feature to **0V Suspend** option and **Soft-Off by PWR-BTTN** feature to **Delay 4 sec.**
2. The Award zero-volt data-suspend utility runs under DOS, Windows 3.1, and Windows 95. However, **you should install the ZVHDD.EXE under DOS - before installing Windows 3.1 or Windows 95.**

6.3 RUNNING THE PROGRAM

6.3.1 INSTALLATION

There is no special installation program. You may run the program ZVHDD.EXE from your hard drive or from a diskette.

When you install ZVHDD, it creates either a binary file or a hard drive partition as you select, in which to store a saved session.

Note: *If you plan to store session data in a separate partition, create a bootable diskette and run ZVHDD from the bootable diskette, because partitioning the hard drive may destroy all existing data on the drive.*

To install the program, type the following at the DOS prompt.

```
ZVHDD/C /file /M:memory_size
OR
ZVHDD/C /partition/M:memory_size
```

where

/C	Creates a file or a disk partition for session data storage
/file	Specifies a storage file name SAVE2DSK.BIN. This is a hidden file.
/partition	Specifies a disk partition for storage of session data.

Note: *Creating a disk partition may cause loss of existing data on the hard drive. We recommend this method only for new systems with no data on the hard drive.*

/M:memory_size	Specifies a number from 1 to 256 to select the size in megabytes of the file or partition.
----------------	--

(I) Creating a Storage File

Here is an example of creating a storage file. The specified memory size, 8MB, is an example only.

1. At the DOS command line, type
ZVHDD/C /file /M:8 ↵
2. A screen similar to this appears:

ZVHDD 1.31--Award EliteBIOS v4.51GPM Zero-Volt Partition Utility Copyright (c) Award Software Inc. 1996. All Rights Reserved.

The file c:\SAVE2DSK.BIN has been created.

The system will now be reset to allow the BIOS to recognize the changes. If the system fails to reboot, please power off the power.

Press any key to reset the system.....

3. Press any key

(II) Creating a Storage Partition on the Hard Disk

Here is an example of creating a storage partition on the hard disk. The specified memory size, 8MB, is an example only.

1. At the DOS command line, type
ZVHDD/C /partition /M:8 ↵
2. If you have adequate space on your hard drive, a screen similar to this appears:

ZVHDD 1.31--Award EliteBIOS v4.51GPM Zero-Volt Partition Utility Copyright (c) Award Software Inc. 1996. All Rights Reserved.

Formatting xxxxxxxxxxxx Bytes.

Press any key to reset the system.....

If you don't have adequate free space on your hard drive, a screen similar to this appears:

**ZVHDD 1.31--Award EliteBIOS v4.51GPM Zero-Volt Partition
Utility Copyright (c) Award Software Inc. 1996. All Rights Reserved.**

Warning: Not enough free disk space exists to create the partition.

**If you wish to make space for the partition, that will DESTROY ALL
the data on your hard disk!!**

OK to proceed, Answer Yes / No?

3. Answer **Yes** to proceed with the disk partitioning. You will then have to install an operating system on your main partition.

6.3.2 SAVING SESSION DATA

After you implement the suspend function in Setup and install a storage file or partition on the hard drive, you can save your session data at any time.

To save session data, just let the system entering to suspend mode:

- press **Power** button on your computer.
- you may let the system time-out according to the Power Management Setting on the BIOS Menu.
- if you a Windows 95 user, just click the **Suspend** icon on Windows 95 Start Menu.

If your system has a built-in software power-off function, the system simply turns itself off.

In systems that do not have a built-in software power-off function, a screen similar to this appears:

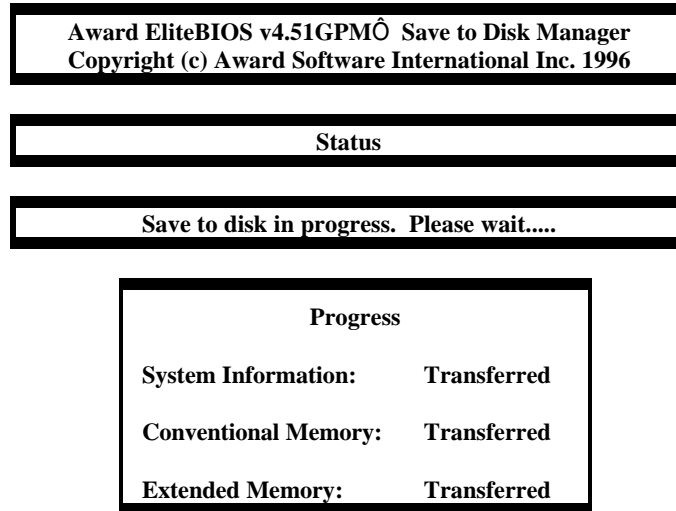

When all data is transferred, the system will be turned off.

When you restart your system, it first runs through the system initialization routine (POST), then returns to the session you were previously running.

6.4 PROGRAM FUNCTIONS

6.4.1 USAGE

You can view a ZVHDD parameters by typing: ZVHDD/? at the DOS prompt. A screen similar to this appears:

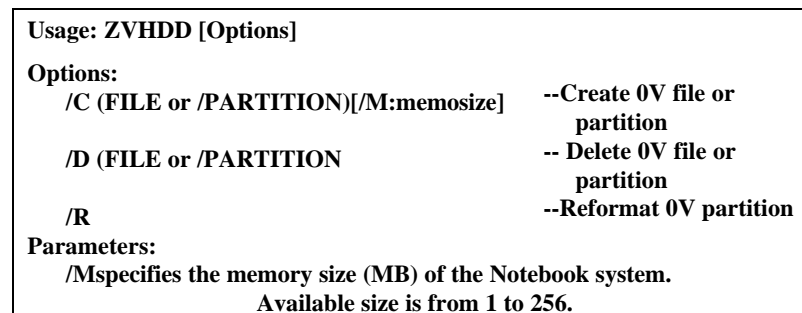

6.4.2 REFORMATTING THE STORAGE PARTITION

If you suspect the storage partition has become corrupted, you can reformat it with the command

ZVHDD /r

6.4.3 DELETING THE STORAGE FILE OR PARTITION

You can delete the storage file or partition with the /D switch.

1. At the DOS prompt, type

ZVHDD /D /file
OR
ZVHDD /D /partition ↵

2. A screen similar to this appears:

<p>ZVHDD 1.31--Award EliteBIOS v4.51GPMÔ Zero-Volt Partition Utility Copyright (c) Award Software Inc. 1996. All Rights Reserved.</p> <p><i>The file c:\SAVE2DSK.BIN has been deleted.</i></p> <p>The system will now be reset to allow the BIOS to recognize the changes. If the system fails to reboot, please power off the power.</p> <p>Press any key to reset the system.....</p>
--

3. Press any key.

CHAPTER 7

FLASH AND DMI UTILITY

7.1 AWARD FLASH UTILITY

This section will provide instructions to guide you through updating your old BIOS. The file name we use to program here is *test.bin*, and the file name to save old BIOS is *2A59F000.OLD*. Please note that those file names are not absolute. They are only examples to let you have a more clear understanding of the updating process.

How to Begin

1. Please type "**awdf**lash" and press the **ENTER** key to begin the updating process.
2. Once you enter, you will see a main menu displaying:

FLASH MEMORY WRITER V5.XX Copyright (C) 1996, Award Software, Inc.,	
For I430HX-2A59F000 Flash Type	DATE: 06/18/96
File Name to Program:	
Error Message:	

Fig. 25

3. Type the program name "*test.bin*", and then press the **ENTER** key.
4. At the bottom of the menu, you will be requested to answer:

"Do You Want to Save BIOS (Y/N)?"

Chapter 7

If you do not wish to save the old BIOS:

5. Please type “N”, and then press the ENTER key.
6. Then you will be request to answer:

“Are You Sure to Program?”

7. Answer “N” if you do not want to program, and then it will exit.

To save the old BIOS:

8. Please respond “Y”, and then press the ENTER key.
9. Move the cursor to “File Name to Save:”
10. Type file name “**2A59F000.OLD**”, and then press the **ENTER**.
(Your old BIOS will be saved in the file name you create. In this case, the old BIOS is saved in the file name, 2A59F000.OLD).
11. Then you will be requested to answer:

“Are You Sure to Program (Y/N)?”

12. Type “Y” to begin programming, and press the **ENTER** key.
13. When the programming is finished, the showing message will appear:

“Programming Flash Memory - 3FF00 0K



Message: Please Power off or Reset System”

14. Once you see the showing message “**Power Off or Reset System**”, please re-start your system.
15. When you power on the computer again, you will find your old BIOS has already been successfully updated.

Warning

Please note that Award Flash Utility cannot run under EMM386 or QEMM. Thus, when executing the command “**awdf**lash”, and error message will appear:

“Error Message: Fail - Due to EMM386 or QEMM!”

7.2 DESKTOP MANAGEMENT INTERFACE (DMI) OVERVIEW

This motherboard can support DMI within the BIOS level. DMI is able to auto-detect and record information pertinent to a computer's system such as the CPU type, CPU speed, and internal/external frequencies, and memory size. The onboard BIOS will detect as many system information as possible and store those collected information in a 4KB block in the motherboard's flash EPROM and allow the DMI to retrieve data from this database.

The DMI Configuration Utility (DMICFG.EXE) must be used in real mode in order for the program to run, the base memory must be at least 180K. Memory managers like HIMEM.SYS (required by windows) must not be installed. You can boot up from a system diskette without AUTOEXEC.BAT and CONFIG.SYS files, "REM" HIMEM.SYS in the CONFIG.SYS, or press <F5> during bootup to bypass your AUTOEXEC.BAT and CONFIG.SYS files.

Using the DMI Configuration Utility

Edit DMI

```

Award DMI Configuration Utility V1.04a, Copyright Award Software Inc. 1996
[Edit DMI] [Add DMI] [Load DMI FILE] [Save DMI FILE]

  BIOS
  System
  Base Board
  Enclosure/Chassis
  Processor
  Memory Controller
  Memory Module
  Memory Module
  Memory Module
  Memory Module
  Cache
  Cache
  Port Connector
  Port Connector
  Port Connector
  Port Connector
  Port Connector
  Port Connector
  Port Connector
  System Slots

==== Display Component ====
Type : BIOS Information
Handle : 0000
Vendor Name : Award Software International, Inc.
BIOS Version : 4.51 PG
BIOS starting Address Segment : E000
BIOS Build Date : 05/12/97
BIOS Characteristics : Press [ENTER] for detail
Size of BIOS ROM : 0128K

↑↓←→-Move cursor ENTER-Accept DEL-Delete ESC-Abort&Exit

```

Chapter 7

Use the ←→ (left-right) cursors to move the top menu items and the ↑↓ (up-down) cursor to move between the left hand menu items. The bottom of the screen will show the available keys for each screen. Press enter at the menu item to enter the right hand screen for editing. “Edit component” appears on top. The reversed color field is the current cursor position and the blue text are available for editing. The orange text shows auto-detected information and are not available for editing. The blue text “Press [ENTER] for detail” contains a second pop-up menu is available, use the + - (plus-minus) keys to change the settings. Enter to exit and save, ESC to exit and not save.

If the user has made changes, ESC will prompt you to answer Y or N. Enter Y to go back to the left-hand screen and save, enter N to go back to left-hand screen and not save. If editing has not been made, ESC will send you back to the left hand menu without any messages.

Add DMI

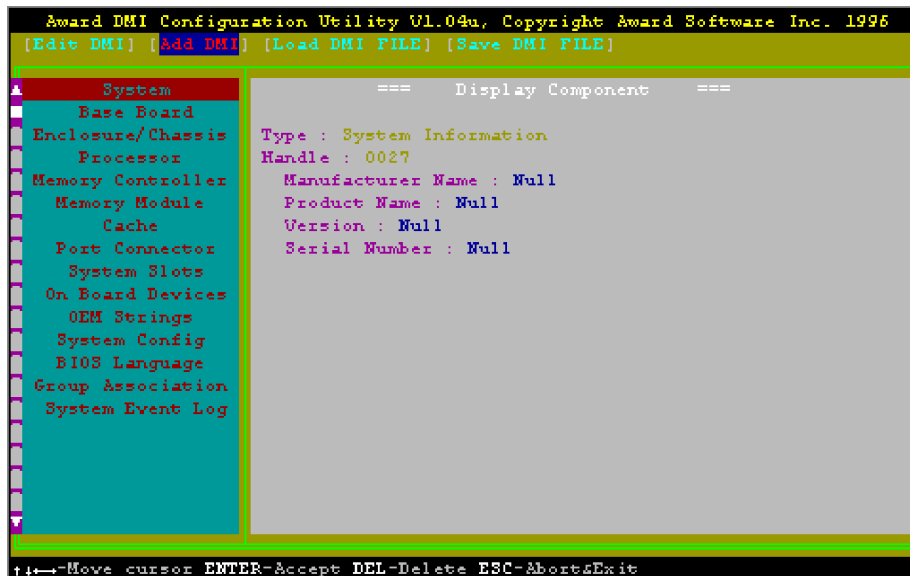

This DMI Configuration Utility also allows the system integrator or end user to add additional information into the DMI database such as serial numbers, housing configurations, and vendor information. Those information not detected by the motherboard BIOS and has to be manually entered through the DMI Configuration Utility and updated into the DMI database.

Load DMI File

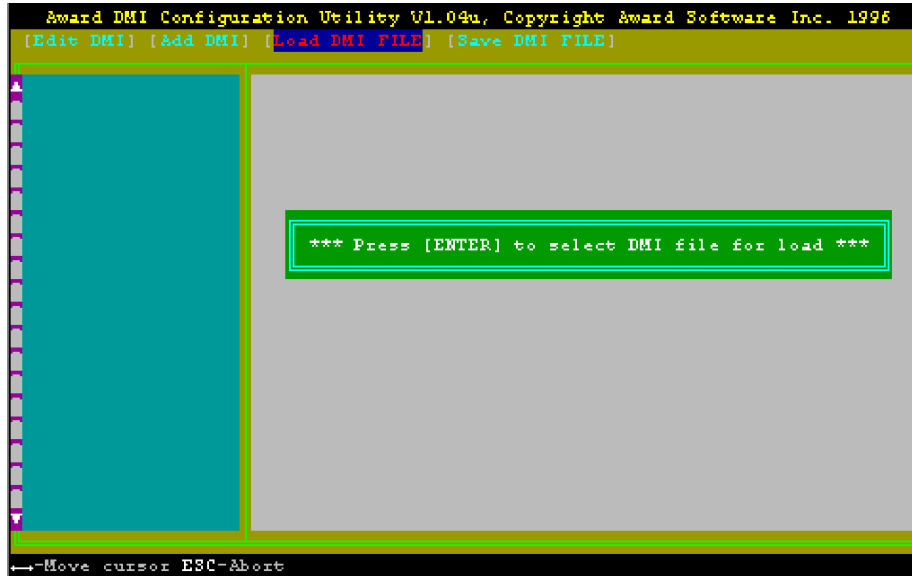

You can load the disk file to memory by entering a drive and path and file name here.

Chapter 7

Save DMI File

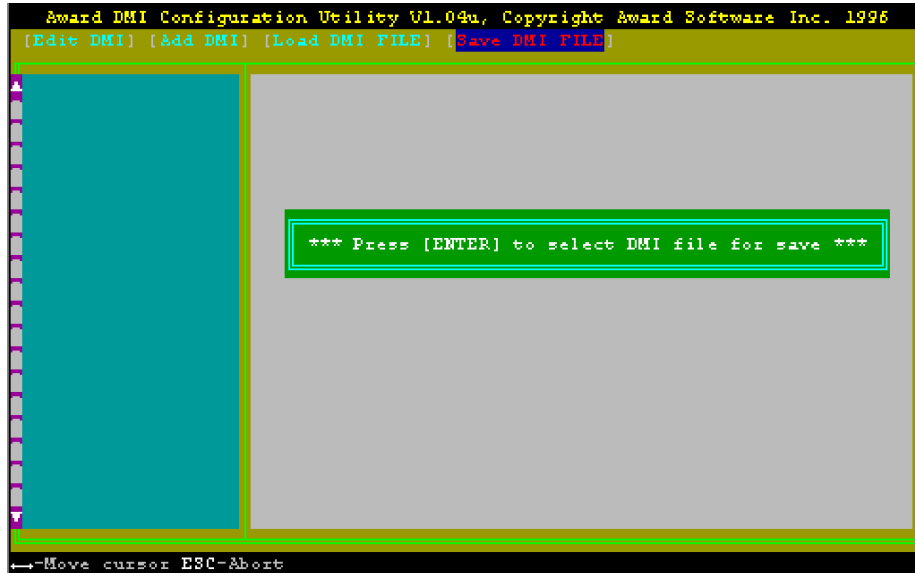

You can save the DMI (normally only saved to flash ROM) to a file by entering the drive and path here. If you want to cancel save, you may press ESC and a message "Bad File Name" appears here to show it was not saved.

APPENDIX A

QUICK GUIDE

The table below summarizes the functions and settings of each jumper of the motherboard.

Function		Jumper Settings	
CPU Voltage Selection	BIOS "CPU Core Voltage" set at "Auto" for all CPU	SW1-1: OFF SW1-2: OFF	
	BIOS CPU Core Voltage set at "2.8/2.9/3.2/3.3/3.5V" for all CPU	SW1-1: OFF SW1-2: OFF	
	BIOS disable	Intel Pentium w/MMX, Cyrix 6x86L, AMD K6/233, 266	SW1-1: OFF SW1-2: OFF
		Intel Pentium, AMD K6/166, 200	SW1-1: ON SW1-2: OFF
	Cyrix 6x86, AMD K5	SW1-1: ON SW1-2: ON	
CPU Speed Selection	For 90MHz Intel Pentium, AMD-K5-PR90 and AMD-K5-PR120 CPU	SW1-3: OFF SW1-4: OFF SW1-5: OFF SW1-6: ON SW1-7: OFF SW1-8: OFF	
	For 100MHz and 233MHz Intel Pentium, AMD-K6/233, AMD-K5-PR100 and AMD-K5-PR150 CPU	SW1-3: OFF SW1-4: OFF SW1-5: OFF SW1-6: OFF SW1-7: OFF SW1-8: OFF	
	For 110MHz Cyrix 6x86-P133+ CPU	SW1-3: ON SW1-4: OFF SW1-5: OFF SW1-6: ON SW1-7: ON SW1-8: OFF	
	For 120MHz Intel Pentium and Cyrix 6x86-P150+ CPU	SW1-3: ON SW1-4: OFF SW1-5: OFF SW1-6: ON SW1-7: OFF SW1-8: OFF	
	For 133MHz Intel Pentium, AMD-K5-PR133 (REV C) and Cyrix 6x86L-P166+ CPU	SW1-3: ON SW1-4: OFF SW1-5: OFF SW1-6: OFF SW1-7: OFF SW1-8: OFF	
To be continued...			

Appendix A

Function		Jumper Settings	
CPU Speed Selection	For 150MHz Intel Pentium and Cyrix 6x86MX-PR166 CPU	SW1-3: SW1-4: SW1-5: SW1-6: SW1-7: SW1-8:	ON ON OFF ON OFF OFF
	For 150MHz Cyrix 6x86L/MX-PR200+ CPU (for future support only)	SW1-3: SW1-4: SW1-5: SW1-6: SW1-7: SW1-8:	ON OFF OFF OFF ON OFF
	For 166MHz Intel Pentium, AMD-K6/166 and AMD-K5-PR166 CPU	SW1-3: SW1-4: SW1-5: SW1-6: SW1-7: SW1-8:	ON ON OFF OFF OFF OFF
	For 200MHz Intel Pentium and AMD-K6/200 CPU	SW1-3: SW1-4: SW1-5: SW1-6: SW1-7: SW1-8:	OFF ON OFF OFF OFF OFF
	For AMD-K6/266 CPU	SW1-3: SW1-4: SW1-5: SW1-6: SW1-7: SW1-8:	OFF OFF ON OFF OFF OFF
On board Sound Chip Selection	Enabled	JP3:	short
	Disabled	JP3:	open
On board VGA Chip Selection	Enabled	JP4 JP5:	2-3 short 1-2 short
	Disabled	JP4: JP5:	1-2 short 2-3 short
Clear RTC CMOS Data	Normal	JP8:	1-2 short
	Clear	JP8:	2-3 short
System ROM Selection	5V Flash EPROM	JP1:	2-3 short
	12V Flash EPROM	JP1:	1-2 short
Reserved Jumpers	For Cyrix CPU	JP6:	short

Appendix A

Appendix A

Appendix A
