

# IM845GL Motherboard

## CONTENTS

- Chapter 1 Motherboard Description  
*Motherboard Overview 1-3*
- Chapter 2 Using the BIOS Setup Program  
*About the Setup Program 2-1*  
*Entering the Setup Program 2-2*  
*BIOS Setup Program 2-4*
- Chapter 3 Installing Board Options  
*Before You Begin 3-1*  
*Installing and Removing the Processor 3-2*  
*Installing and Removing Memory Modules 3-5*  
*Changing the Jumpers 3-7*  
*Replacing the Battery 3-8*  
*The Things to do in Post-installation 3-9*
- Appendix A Specifications  
*Specifications A-1*

---

# Safety Information

## Battery Warning Instruction

### Caution

If battery is incorrectly replaced there poses a danger of explosion. Replace battery only with the same or equivalent type recommended by the manufacturer. Discard used batteries according to the manufacturer's instructions.

### Attention

Il y a danger d'explosion s'il y a remplacement incorrect de la batterie. Remplacer uniquement avec une batterie du même type ou d'un type recommandé par le constructeur. Mettre au rebut les batteries usagées conformément aux instructions du fabricant.

### Vorsicht

Explosionsgefahr bei unsachgemäß em Austausch der Batterie. Ersatz nur durch denselben oder einen vom Hersteller empfohlenen ähnlichen Typ. Entsorgung gebraushter Batterien nach Angaben des Herstellers.

## Fuse Warning Instruction

### Caution

For continued protection against risk of fire, replace only with same type and rating of fuse. Disconnect input power before servicing. Only connect this equipment to an earthed socket outlet.

### Vorsicht

Vor jeder service-arbeit netzstecker ziehen! Apparatet ma kun tilkobles jordet stikkontakt.

### Attention

Debrancher avant d'ouvrir. Apparatet skall anslutas till jordat nätuttag.

### Atencion

Desconecte fuerza electrica antes del servicio. Laite on liitettävä suojäkosketinistoraasian.

---

## Before You Read

The information in this user's guide is subject to change without notice.

eMachines, Inc. shall not be liable for technical or editorial errors or omissions contained herein; nor for incidental or consequential damages resulting from the furnishing, performance, or use of this material.

eMachines, stylized "e" and figure logo are trademarks of eMachines, Inc. in the United States and/or other countries.

All other product and brand names are trademarks of their respective owners.

©2002 eMachines, Inc. All rights reserved.

### **NOTE**

*Depending on the model, your computer's components may vary and look slightly different than those pictured.*

# CONTENTS

## **Chapter 1      *Motherboard Description***

Motherboard Overview .....	1-3
Rear Panel Connectors .....	1-4

## **Chapter 2      *Using the BIOS Setup Program***

About the Setup Program .....	2-1
Entering the Setup Program .....	2-2
Help Window .....	2-3
BIOS Setup Program .....	2-4
Main Menu .....	2-4
Advanced Menu .....	2-6
Security Menu .....	2-8
Power Menu .....	2-9
Boot Menu .....	2-10
Exit Menu .....	2-10

---

## **Chapter 3**      **Installing Board Options**

Before You Begin .....	3-1
Installing and Removing the Processor .....	3-2
Installing the Processor .....	3-2
Removing the Processor .....	3-4
Installing and Removing Memory Modules .....	3-5
Installing a Memory Module .....	3-6
Removing a Memory Module .....	3-6
Changing the Jumpers .....	3-7
Replacing the Battery .....	3-8
The Things to do in Post-installation .....	3-9

## **Appendix A**      **Specifications**

Specifications .....	A-1
----------------------	-----

# *Chapter 1*

## **Motherboard Description**

This chapter describes the major features of your motherboard.

Your motherboard offers the following features:

- Micro ATX form factor
- Intel® Pentium® 4 processor in the mPGA 478 pin package
- Two DIMM sockets, expandable up to 2 GB using 1 GB DDR SDRAM modules
- Two built-in Enhanced IDE controllers
- Intel® 82845GL Graphics Memory Controller Hub (GMCH)
- Intel® 82801DB I/O Controller Hub (ICH4)
- Built-in high performance audio CODEC and PCI audio controller in Intel® 82845GL GMCH
- SMSC LPC47M192 super I/O controller
- Realtek RTL8100B LAN controller
- Advanced Power Management (APM) and Advanced Configuration and Power Interface (ACPI)
- Three 32-bit PCI expansion card connectors
- System BIOS and video BIOS shadow RAM
- Plug-and-Play (PnP) BIOS feature
- Password function by using BIOS

- 
- Video memory using main memory

**NOTE**

*The internal graphics device on Intel 82845GL supports Intel Dynamic Video Memory Technology (D.V.M.T). D.V.M.T. dynamically responds to application requirements by allocating the proper amount of display and texturing memory.*

*As your system has sharing memory architecture using the main memory for video memory, the usable main memory size is less than real size when the computer is running.*

- Two PS/2 style connectors for keyboard and mouse
- One video connector
- Four USB 2.0 connectors
- One LAN connector
- One serial port connector
- One parallel port connector
- Three audio jacks

# Motherboard Overview

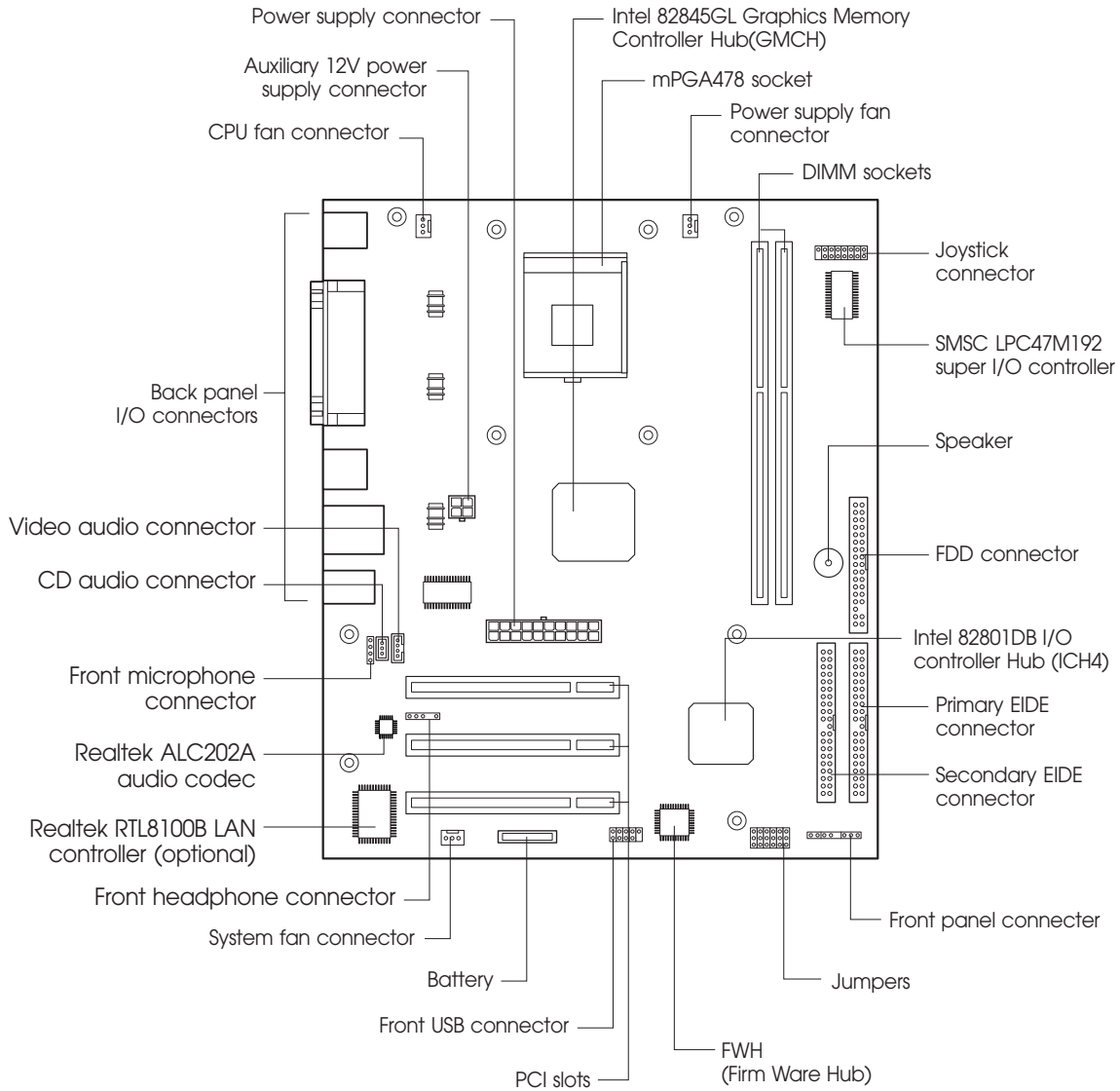

## NOTE

*The motherboard's components may vary and look slightly different.*



---

## Rear Panel Connectors

The motherboard has connectors for peripheral devices.

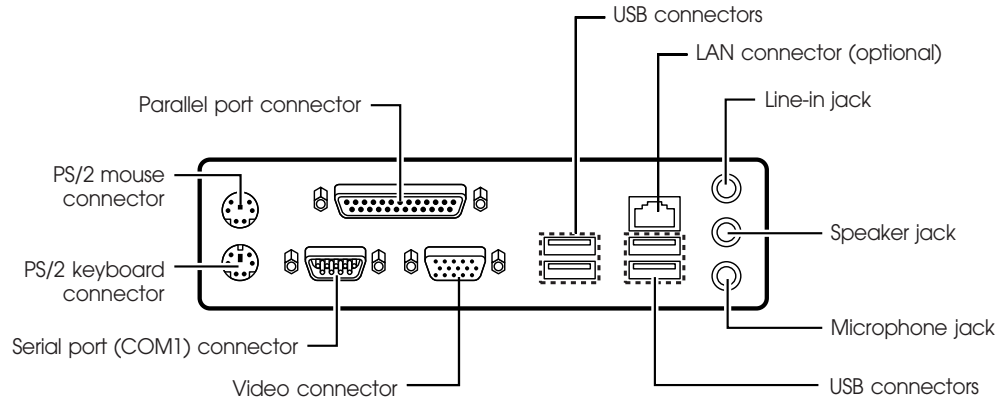

# *Chapter 2*

## **Using the BIOS Setup Program**

This chapter explains how to use the BIOS Setup program. You can use the Setup program to change the computer's configuration information and boot-up sequence, etc.

### **About the Setup Program**

Your system uses a Phoenix BIOS, which is stored in flash memory on the motherboard. This enables you to run the program at any time when you turn on or reset your computer.

The configuration you define through the Setup program is stored in a special area of memory called CMOS RAM. The battery on the motherboard backs up this memory, so the memory is not erased when you turn off or reset the computer. Whenever you reboot the computer, it checks the settings, and if it discovers a difference between the information in the CMOS RAM and its actual hardware configuration, it prompts you to run the Setup program.

---

## Entering the Setup Program

To enter the Setup program, turn the computer on and press DEL as soon as you see the “emachines” logo.

If you do not press the key quickly, the computer starts loading the operating system.

### NOTE

*For reference purposes, write down the current Setup settings. When you make changes to the settings, update this record.*

When you enter the Setup program, you will see the Setup menu. The legend bar at the bottom of the menu displays function keys used in Setup.

### NOTE

*The actual menus displayed on your system may differ depending on the hardware and features installed in your computer.*

The Setup program is for viewing and changing the BIOS settings for a computer. Setup is accessed by pressing the <DEL> key after the Power-On Self Test (POST) begins and before the operating system boot begins.

The next table shows the menus available from the menu bar at the top of the Setup screen.

Setup Menu Screen	Description
Main	Allocates resources for hardware components.
Advanced	Specifies advanced features available through the chipset.
Security	Specifies passwords and security features.
Power	Specifies power management features.
Boot	Specifies boot options and power supply controls.
Exit	Saves or discards changes to the Setup program options.

---

The next table shows the function keys available for menu screens.

Setup Key	Description
<F1> or <Alt-H>	Brings up a help screen for the current item.
<Esc>	Exits the menu.
<←> or <→>	Selects a different menu screen.
<↑> or <↓>	Moves cursor up or down.
<Home> or <End>	Moves cursor to top or bottom of current menu.
<PgUp> or <PgDn>	Moves cursor to previous or next page on scrollable menu.
<F5> or <->	Selects the previous value for a field.
<F6> or <+> or <Space>	Selects the next value for a field.
<F9>	Load the default configuration values for the current menu.
<F10>	Save the current values and exit Setup.
<Enter>	Executes command or selects the submenu.

## ***Help Window***

The field help window on the right of each menu displays the help text for the currently selected field. Also, if pressing <F1> on any menu, you will see the General Help.

---

# BIOS Setup Program

## Main Menu

This menu reports processor and memory information and is for configuring the system date, system time, floppy options, and IDE devices.

Feature	Options	Description
System Time	Hour, minute, and second	Specifies the current time.
System Date	Month, day, and year	Specifies the current date.
Language	<ul style="list-style-type: none"><li>• English (US)</li><li>• Français</li><li>• Español</li></ul>	You can select the display language for the BIOS.
Legacy Diskette A:	<ul style="list-style-type: none"><li>• Disabled</li><li>• 360 KB, 5 ¼"</li><li>• 1.2 MB, 5 ¼"</li><li>• 720 KB, 3 ½"</li><li>• 1.44/1.25 MB, 3 ½"</li><li>• 2.88 MB, 3 ½"</li></ul>	Specifies the capacity and physical size of diskette drive A.
Primary IDE Master, submenu	No options	Reports type of connected IDE device. When selected, displays the Primary IDE Master submenu.
Primary IDE Slave, submenu	No options	Reports type of connected IDE device. When selected, displays the Primary IDE Slave submenu.
Secondary IDE Master, submenu	No options	Reports type of connected IDE device. When selected, displays the Secondary IDE Master submenu.
Secondary IDE Slave, submenu	No options	Reports type of connected IDE device. When selected, displays the Secondary IDE Slave submenu.
System Memory	No options	Displays the amount of system memory.
Extended Memory	No options	Displays the amount of Extended memory.

---

## IDE Device Configuration Submenus

This submenu is for configuring IDE devices, including:

- Primary IDE master/slave
- Secondary IDE master/slave

Feature	Options	Description
Type	<ul style="list-style-type: none"><li>• Auto</li></ul>	Auto automatically fills in the values for the cylinders, heads, and sectors fields.
Multi-Sector Transfers	No options	Displays the number of sectors per block for transfers from the hard drive to memory.
LBA Mode Control	No options	Displays the status of logical block addressing control.
32 Bit I/O	<ul style="list-style-type: none"><li>• Disabled</li><li>• Enabled</li></ul>	Enables or disables 32 bit communication between CPU and IDE card. Requires PCI or local bus.
Transfer Mode	No options	Displays the method for transferring data between the hard drive and system memory.
Ultra DMA Mode	No options	Displays the ultra DMA mode for the hard drive.

---

## Advanced Menu

This menu is for setting advanced features that are available through the chipset.

Feature	Options	Description
CPU Type	No options	Displays the processor type.
CPU Speed	No options	Displays the processor speed.
Cache Ram	No options	Displays the amount of cache RAM.
Plug & Play O/S	<ul style="list-style-type: none"><li>• No</li><li>• Yes</li></ul>	If you select Yes, the BIOS configures Plug and Play devices when your system has a Plug & Play operating system.
Reset Configuration Data	<ul style="list-style-type: none"><li>• No</li><li>• Yes</li></ul>	Yes erases all configuration data in ESCD, which stores the configuration settings for non-PnP plug-in devices. Select Yes when required to restore the manufacturer's defaults.
Primary Video Adapter	<ul style="list-style-type: none"><li>• PCI</li><li>• Onboard</li></ul>	This option lets you define the type of your video adapter you are using for your primary display.
Local Bus IDE adapter	<ul style="list-style-type: none"><li>• Disabled</li><li>• Primary</li><li>• Secondary</li><li>• Both</li></ul>	Allows you to set the built-in IDE controller you want to use.
Large Disk Access Mode	<ul style="list-style-type: none"><li>• Other</li><li>• DOS</li></ul>	Select DOS if you have DOS. Select Other if you have another operating system such as UNIX. A large disk is one that has more than 1024 cylinders, more than 16 heads, or more than 63 tracks per sector.
Legacy USB Support	<ul style="list-style-type: none"><li>• Disabled</li><li>• Enabled</li></ul>	Enables or disables the legacy USB.
Onboard LAN Control	<ul style="list-style-type: none"><li>• Disabled</li><li>• Enabled</li></ul>	Enables or Disables the onboard LAN. Select Disabled, if you don't want use onboard LAN function.
Memory performance	<ul style="list-style-type: none"><li>• Auto</li><li>• Max</li></ul>	Specifies method for memory performance. If you select Auto, the system automatically set the SDRAM timing by SPD (Serial Presence Detect). SPD is an EEPROM chip on the DIMM module that stores information about the memory chips it contains, including size, speed, voltage, row and column addresses, and manufacturer. If you select Max, the system set the SDRAM timing fully.
I/O Device Configuration, Submenu	No options	Configures I/O devices. When selected, displays the I/O Device Configuration submenu.
Onboard Audio Options, Submenu	No options	Configures onboard audio. When selected, displays the Onboard Audio Options submenu.
Hardware Monitor, Submenu	No options	Reports the speed of the CPU fan and system fan. When selected, displays the Hardware Monitor submenu.

---

## I/O Device Configuration Submenu

This submenu is for configuring the I/O devices.

Feature	Options	Description
Serial port A:	<ul style="list-style-type: none"><li>• Disabled</li><li>• Enabled</li></ul>	Configures serial port. If you select Enabled, you must assign the address and interrupt.
Base I/O address	<ul style="list-style-type: none"><li>• 3F8</li><li>• 2F8</li><li>• 3E8</li><li>• 2E8</li></ul>	Selects the base I/O address for serial port.
Interrupt	<ul style="list-style-type: none"><li>• IRQ 3</li><li>• IRQ 4</li></ul>	Selects the interrupt for the serial port.
Parallel port	<ul style="list-style-type: none"><li>• Disabled</li><li>• Enabled</li></ul>	Configures the parallel port.
Mode	<ul style="list-style-type: none"><li>• Bi-directional</li><li>• EPP</li><li>• ECP</li></ul>	Selects the mode for the parallel port.
Base I/O address	<ul style="list-style-type: none"><li>• 378</li><li>• 278</li><li>• 3BC</li></ul>	Selects the base I/O address for parallel port.
Interrupt	<ul style="list-style-type: none"><li>• IRQ 5</li><li>• IRQ 7</li></ul>	Selects the interrupt for the parallel port.
DMA channel	<ul style="list-style-type: none"><li>• DMA 1</li><li>• DMA 3</li></ul>	Selects the DMA channel for the parallel port.

## Onboard Audio Options Submenu

This submenu is for configuring the onboard audio.

Feature	Options	Description
Audio codec	<ul style="list-style-type: none"><li>• Disabled</li><li>• Enabled</li><li>• Auto</li></ul>	Select Disabled, if you don't want use AC'97 audio.
MIDI port	<ul style="list-style-type: none"><li>• Disabled</li><li>• Enabled</li></ul>	Configures the MIDI port.
Base I/O address	<ul style="list-style-type: none"><li>• 300 - 301</li><li>• 308 - 309</li><li>• 310 - 311</li><li>• 318 - 319</li></ul>	Selects the base I/O address for the MIDI port.
Interrupt	<ul style="list-style-type: none"><li>• 5</li><li>• 10</li></ul>	Selects the interrupt for the MIDI port.
Game port	<ul style="list-style-type: none"><li>• Disabled</li><li>• Enabled</li></ul>	Configures the Game port.
Base I/O address	<ul style="list-style-type: none"><li>• 201</li><li>• 209</li><li>• 211</li><li>• 219</li></ul>	Selects the base I/O address for the Game port.



---

## Hardware Monitor Submenu

This submenu reports the speed of CPU fan and system fan.

Feature	Options	Description
CPU Fan Speed	No options	Displays the CPU fan speed.
System Fan Speed	No options	Displays the system fan speed.

## Security Menu

This menu is for setting passwords and security features.

Feature	Options	Description
Set Supervisor Password	Password can be up to seven alphanumeric characters.	Specifies the supervisor password.
Set User Password	Password can be up to seven alphanumeric characters.	Specifies the user password.
Password On Boot	<ul style="list-style-type: none"><li>• Disabled</li><li>• Enabled</li></ul>	Enables password entry on boot.

If you set both the Supervisor and User passwords, you must set the Supervisor password first. Once both are set, you can enter either the Supervisor password or the User password to access the Setup or the computer.

The table shows the effects of setting the Supervisor and User passwords.

Password set	Supervisor mode	User mode	Password during boot	Password to enter the Setup Program
Neither	Can change all options	Can change all options	None	None
Supervisor only	Can change all options	N/A	Supervisor	Supervisor
Both	Can change all options	Can change a limited number of options	Supervisor or User	Supervisor or User

### NOTE

*Be sure to remember the password you enter or write it down. You will not be able to access the computer the next time you turn it on or run SETUP without the password.*

---

## Deleting or Changing a Password

If you want to delete the current password, follow these steps:

1. Press Enter at Set User Password or Set Supervisor Password from the Security menu.
2. Type the current password in “Enter Current Password” and press Enter.
3. Just press Enter in “Enter New Password” to delete your current password.
4. When you see “Confirm New Password”, press Enter again.
5. When you see the following message, press Enter.

Changes have been saved.

To change the current password, type your new password before pressing Enter on steps 3 and 4.

## Power Menu

This menu is for setting power features.

Feature	Options	Description
After AC Power Failure	<ul style="list-style-type: none"><li>• Stay Off</li><li>• Auto</li><li>• Power On</li></ul>	Specifies how the computer responds to a power failure or when you connect the AC power cable to your computer. If you set it to Stay Off, the computer keeps power off until power button pressed. If you set it to Power On the computer restores power.

---

## Boot Menu

This menu is for setting the boot sequence.

Feature	Options	Description
Boot-time Diagnostic Screen	<ul style="list-style-type: none"><li>• Disabled</li><li>• Enabled</li></ul>	Displays system summary screen during bootup.
Quick Boot Mode	<ul style="list-style-type: none"><li>• Enabled</li><li>• Disabled</li></ul>	Enables the computer to boot without running certain POST tests.
Boot Device Priority	<ul style="list-style-type: none"><li>• No options</li></ul>	Specifies the search order for the types of boot devices

### Boot Device Priority Submenu

You can select the boot sequence from the available devices.

To specify boot sequence:

1. Select the boot device with <↑> or <↓>.
2. Press <+> to move the device up the list or <-> to move the device down the list.

## Exit Menu

This menu is for exiting the Setup program, saving changes, and loading and saving defaults.

Feature	Description
Exit Saving Changes	Exits and saves the changes in CMOS RAM.
Exit Discarding Changes	Exits without saving any changes made in Setup.
Load Setup Defaults	Loads the default values for all the Setup options.
Discard Changes	Discards changes without exiting Setup. The option values (present when the computer was turned on) are used.
Save Changes	Saves the changes in CMOS RAM.

# Chapter 3

## Installing Board Options

This chapter describes how to install board options in your computer. You can use these instructions to install a variety of devices and board options. Although your board options may look a bit different from the ones illustrated herein, you can install and remove it the same way.

### Before You Begin

#### WARNINGS

*The procedures in this chapter assume familiarity with the general terminology associated with personal computers and with the safety practices and regulatory compliance required for using and modifying electronic equipment.*

*Disconnect the computer from its power source and from any telecommunications links, networks, or modems before performing any of the procedures described in this chapter. Failure to disconnect power, telecommunications links, networks, or modems before you open the computer or perform any procedures can result in personal injury or equipment damage. Some circuitry on the motherboard can continue to operate even though the front panel power button is off.*

#### CAUTION

*Electrostatic discharge (ESD) can damage components. Perform the procedures described in this chapter only at an ESD workstation. If such a station is not available, you can provide some ESD protection by wearing an antistatic wrist strap and attaching it to a metal part of the computer chassis.*

---

# Installing and Removing the Processor

The processor that you install must be compatible with mPGA478 socket.

## Installing the Processor

To install the processor, follow these steps:

1. See the illustration in “Motherboard Overview” in Chapter 1 for the location of the processor socket.

### NOTE

*According to processor type, your actual process may be slightly different from one described below.*

### WARNING

*A processor you plan to install should have a fan type heatsink attached to it to prevent overheating. If there is no fan type heatsink, the processor may overheat and cause damage to both the processor and motherboard.*

2. Pull the ZIF handle sideways away from the socket then upward to 90-degree angles.

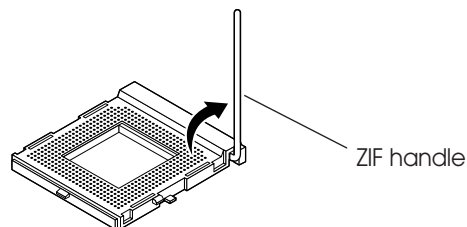

3. Locate the new processor you are installing over the socket so that the marked with triangle corner on the processor can be aligned with the first blank corner on the socket. Then gently push the processor straight into the socket until its pins are completely inserted into the holes of the socket.

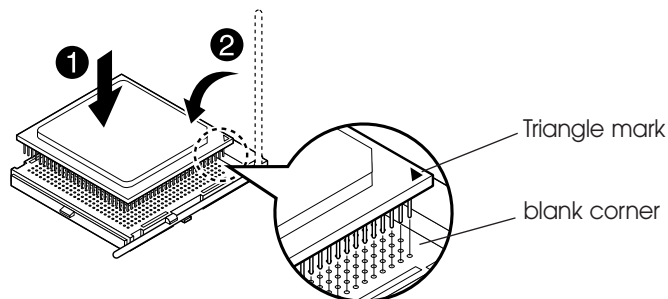

---

## 3-2 Installing Board Options

4. Press the ZIF handle back to close it.
5. Attach the heatsink to the processor socket.

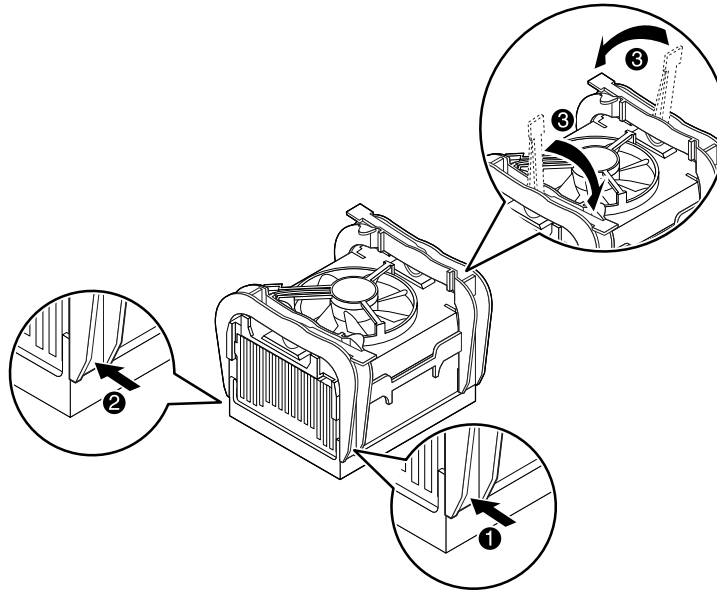

#### **NOTE**

*Depending on the model, the heatsink may vary.*

6. Connect the fan connector cable from the CPU fan to the CPU fan connector on the motherboard.

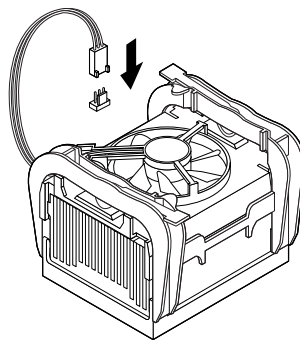

#### **NOTE**

*If you install the processor chip in the wrong orientation, you may burn the chip and void your warranty.*

---

## Removing the Processor

To remove the processor, follow these steps:

1. Unplug the cable connector from the CPU fan connector on the motherboard.

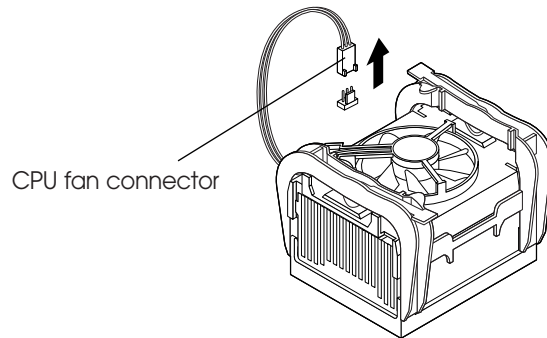

2. Remove the heatsink by releasing both tabs on the heatsink that secure the heatsink to the socket.

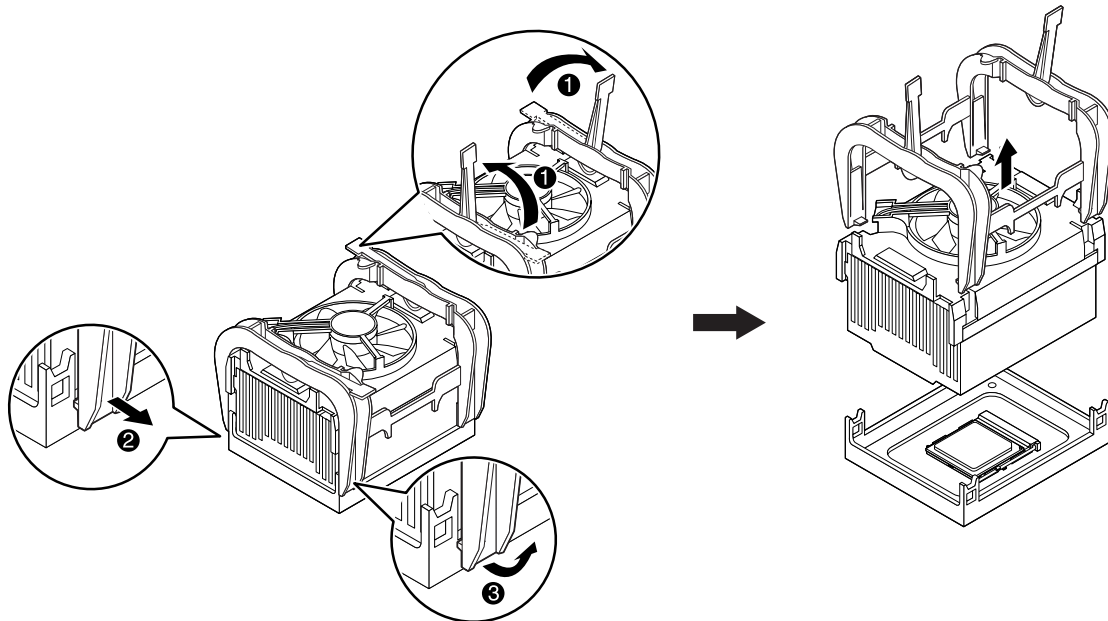

### NOTE

*Depending on the model, the heatsink may vary.*

3. Pull the ZIF handle sideways away from the socket then upward to 90-degree angles and carefully pull the chip straight up from the socket.

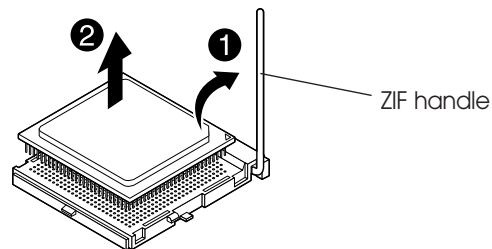

4. Press the ZIF handle back to close it.

## Installing and Removing Memory Modules

The motherboard has two dual inline memory module (DIMM) sockets. You can increase the amount of memory in your computer up to 2 GB.

Each DIMM socket supports the following memory features:

- 184-pin 2.5 V DIMM with gold-plated contacts
- 200/266 MHz Non-ECC unbuffered DDR SDRAM
- Single or double sided DIMM in the following sizes:

DIMM Size	Non-ECC Configuration
64MB	8 Mbit × 64
128MB	16 Mbit × 64
256MB	32 Mbit × 64
512MB	64 Mbit × 64
1 GB	128 Mbit × 64



---

## Installing a Memory Module

Follow these steps to install DIMMs:

1. Release the plastic retaining clips at each end of the socket by pressing the clips outward until they snap open.
2. Orient a DIMM to the socket so the notch in the DIMM connector are aligned with the crossbars in the socket.
3. Press the DIMM straight down until retaining tabs snap into place around the ends of the DIMM.

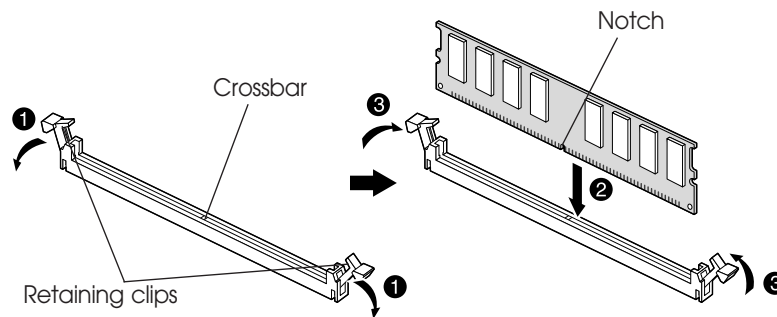

## Removing a Memory Module

To remove memory modules, press the retaining clips outward simultaneously until the DIMM disengages from the socket and then carefully remove the DIMM from the socket.

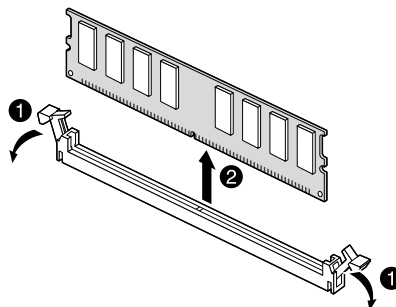

---

## Changing the Jumpers

The jumpers are small electrical connectors that control various circuits or functions in your system. Jumpers are small blocks on a circuit board with two or more pins emerging from them. To change a jumper setting, pull the plug off its pins and carefully fit it down onto the pins indicated.

The jumper settings in your computer are preset at the factory; however, you can alter the functions by changing the standard settings:

- Enable or disable the password function.
- Clear the CMOS settings.
- Enable or disable the FDD write protect.
- Enable or disable the CMOS Setup control.

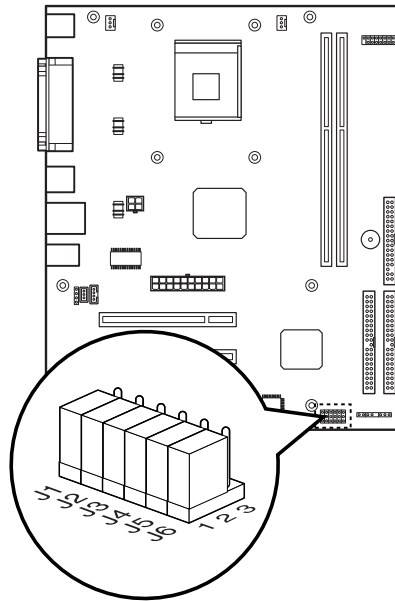

### NOTE

*The jumper settings and their functions are inscribed on the motherboard or label attached in your system chassis. If you want to see the label, you need to remove the cover of your system.*

### CAUTION

*Do not change the jumpers with the power on. Always turn off the computer and unplug the power cord from the computer before changing the jumpers.*

---

## Replacing the Battery

The 3 V, coin-cell CR2032-type battery on the mainboard provides power to the real-time clock and CMOS RAM. It has an estimated lifetime of three years if the computer is turned off.

To replace the battery, follow these steps:

1. Turn off all peripheral devices connected to the computer and then turn off the computer.
2. Disconnect all cables from computer.
3. Remove the system cover.
4. Remove the battery out of its socket with your fingers.

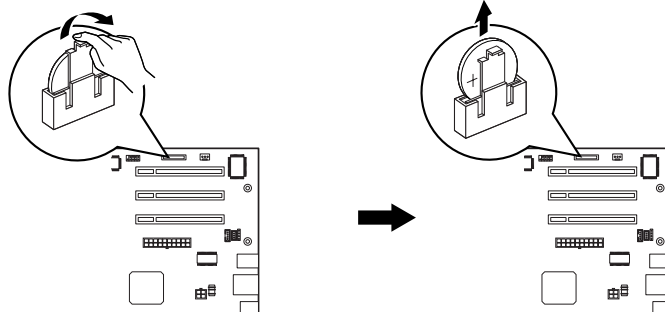

5. Insert the new battery with the “+” side as shown below.

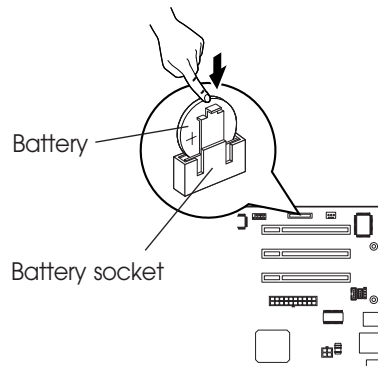

6. Replace the system cover.
7. Connect all cables to your computer.

---

## The Things to do in Post-installation

After you install or remove board options, if necessary, be sure to run Setup program to update the configuration of your system. See Chapter 2 for detail information.

If you installed a new optional equipment and Windows has installed in your system, you need to have Windows detects it. See Windows manual and the manual that came with your optional equipment for detail information.

---

*Blank*

---

**3-10** *Installing Board Options*

# Appendix A

## Specifications

Feature	Specifications
Form Factor	Micro ATX
Processor	<ul style="list-style-type: none"> <li>Intel® Pentium® 4 processor</li> <li>400 MHz system bus with an integrated 256K L2 cache</li> </ul> <p><b>NOTE</b> The processor depends on the model of computer you purchased.</p>
Memory	<ul style="list-style-type: none"> <li>Two 184-pin 2.5 V DIMM sockets</li> <li>Each slot supports up to 1 GB memory of 200/266 MHz Non-ECC</li> <li>Unbuffered DDR Synchronous DRAM (DDR SDRAM)</li> </ul>
	<p>Video memory</p> <ul style="list-style-type: none"> <li>Use main memory (Intel Dynamic Video Memory Technology)</li> </ul> <p><b>NOTE</b> As your system has sharing memory architecture using the main memory for video memory, the usable main memory size is less than real size when the computer is running</p>
Main Chipset	<p>Intel® 82845GL Graphics Memory Controller Hub (GMCH)</p> <ul style="list-style-type: none"> <li>Processor/Host bus support</li> <li>Integrated DRAM controller</li> <li>Integrated graphics AC '97 controller</li> <li>Integrated 3D/2D graphics accelerator</li> <li>Integrated 350 MHz RAMDAC</li> <li>Arithmetic stretch blitter video</li> <li>Power management functions</li> </ul>
	<p>Intel® 82801DB I/O Controller Hub (ICH4)</p> <ul style="list-style-type: none"> <li>Support for the PCI interface</li> <li>Integrated IDE controller</li> <li>USB 2.0 and DMA controller</li> <li>Power management logic</li> <li>Real-time clock</li> <li>Support for AC '97 audio devices</li> </ul>
	<p>Intel® 82802AB Firmware Hub (FWH)</p> <ul style="list-style-type: none"> <li>Firmware Hub (FWH) interface</li> </ul>
I/O Controller	<p>SMSC LPC47M192 Super I/O Controller</p> <ul style="list-style-type: none"> <li>Floppy drive interface</li> <li>One multimode parallel port</li> <li>FIFO serial port</li> <li>Keyboard and mouse controller</li> </ul>

Feature	Specifications
Built-in Audio Controller	Integrated Audio Controller in Intel® 82801DB I/O Controller Hub (ICH4) <ul style="list-style-type: none"> <li>• AC '97 2.2 Compliant</li> <li>• AC '97 Link for Audio CODEC</li> <li>• Separate Independent PCI Function for Audio</li> </ul> AD 1981A Audio Codec '97 <ul style="list-style-type: none"> <li>• AC '97 2.2 compatible</li> <li>• Industry Leading Mixed Signal Technology</li> <li>• 16-bit stereo full-duplex Codec with independent and variable sampling rate</li> <li>• Four analog line-level stereo inputs for connection from LINE IN, CD, VIDEO and AUX</li> <li>• Advanced power management</li> </ul>
Built-in LAN Controller	Realtek RTL8100B LAN controller <ul style="list-style-type: none"> <li>• Integrated Fast Ethernet MAC, physical chip and transceiver in one chip</li> <li>• Supports 10Mbps and 100Mbps N-way Auto-negotiation operation</li> <li>• Supports 32-bit bus master data transfer</li> <li>• Supports wake up LAN function</li> </ul>
Expansion Slots	<ul style="list-style-type: none"> <li>• Three PCI slots</li> </ul>
Other Features	<ul style="list-style-type: none"> <li>• Phoenix BIOS</li> <li>• Plug and Play compatible</li> <li>• Advanced Power Management (APM) and Advanced Configuration Power Interface (ACPI)</li> </ul>
Power Supply	The power supply specifications are inscribed on the label that attached on the power supply chassis in the system. To see the specifications of the power supply, refer to the label. If you want to see the label, you need to remove the cover of your system.
Environmental Requirement	<ul style="list-style-type: none"> <li>• Temperature               <ul style="list-style-type: none"> <li>- Operation : +5°C to 35°C</li> <li>- Storage : -10°C to 55°C</li> </ul> </li> <li>• Humidity               <ul style="list-style-type: none"> <li>- Operation : 30% to 80% (No condensation)</li> <li>- Storage : 20% to 90%</li> </ul> </li> </ul>

## A-2 Specifications



Mat. No. 133555-AM